

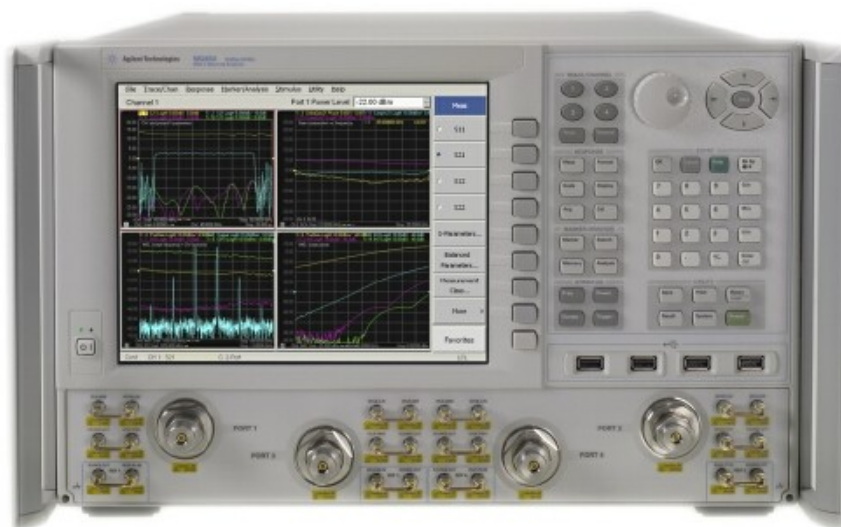
# Agilent 2-Port and 4-Port PNA-X Network Analyzer

**N5244A - 10 MHz to 43.5 GHz**

**N5245A - 10 MHz to 50.0 GHz**

Data Sheet and

Technical Specifications



## **Documentation Warranty**

THE MATERIAL CONTAINED IN THIS DOCUMENT IS PROVIDED "AS IS," AND IS SUBJECT TO BEING CHANGED, WITHOUT NOTICE, IN FUTURE EDITIONS. FURTHER, TO THE MAXIMUM EXTENT PERMITTED BY APPLICABLE LAW, AGILENT DISCLAIMS ALL WARRANTIES, EITHER EXPRESS OR IMPLIED WITH REGARD TO THIS MANUAL AND ANY INFORMATION CONTAINED HEREIN, INCLUDING BUT NOT LIMITED TO THE IMPLIED WARRANTIES OF MERCHANTABILITY AND FITNESS FOR A PARTICULAR PURPOSE. AGILENT SHALL NOT BE LIABLE FOR ERRORS OR FOR INCIDENTAL OR CONSEQUENTIAL DAMAGES IN CONNECTION WITH THE FURNISHING, USE, OR PERFORMANCE OF THIS DOCUMENT OR ANY INFORMATION CONTAINED HEREIN. SHOULD AGILENT AND THE USER HAVE A SEPARATE WRITTEN AGREEMENT WITH WARRANTY TERMS COVERING THE MATERIAL IN THIS DOCUMENT THAT CONFLICT WITH THESE TERMS, THE WARRANTY TERMS IN THE SEPARATE AGREEMENT WILL CONTROL.

## **DFARS/Restricted Rights Notice**

If software is for use in the performance of a U.S. Government prime contract or subcontract, Software is delivered and licensed as "Commercial computer software" as defined in DFAR 252.227-7014 (June 1995), or as a "commercial item" as defined in FAR 2.101(a) or as "Restricted computer software" as defined in FAR 52.227-19 (June 1987) or any equivalent agency regulation or contract clause. Use, duplication or disclosure of Software is subject to Agilent Technologies' standard commercial license terms, and non-DOD Departments and Agencies of the U.S. Government will receive no greater than Restricted Rights as defined in FAR 52.227-19(c)(1-2) (June 1987). U.S. Government users will receive no greater than Limited Rights as defined in FAR 52.227-14 (June 1987) or DFAR 252.227-7015 (b)(2) (November 1995), as applicable in any technical data.

<b>Definitions .....</b>	<b>6</b>
<b>Corrected System Performance .....</b>	<b>7</b>
System Dynamic Range and Receiver Dynamic Range .....	7
Table 1. System Dynamic Range, Options 200 or 400, and Receiver Dynamic Range, All Options .	8
Table 2a. System Dynamic Range at Test Port (dB), Options 200 or 400 .....	9
Table 2b. System Dynamic Range at Test Port (dB), Options 219 or 419 .....	10
Table 2c. System Dynamic Range at Test Port (dB), Option 224.....	11
Table 2d. System Dynamic Range at Test Port (dB), Options 224 or 423 .....	12
Table 2e. System Dynamic Range at Test Port (dB), Options 224 or 423 with 029 <sup>1</sup> .....	13
Table 3a. Extended Dynamic Range at Direct Receiver Access Input (dB) - Specification .....	14
Table 3b. Extended Dynamic Range at Direct Receiver Access Input (dB), Options 224 or 423...	15
Table 3c. Extended Dynamic Range at Direct Receiver Access Input (dB), Options 224 or 423 with 029 <sup>1</sup> .....	16
.....	
<b>N5244A and N5245A Corrected System Performance, All Options .....</b>	<b>17</b>
Table 4. 85056A Calibration Kit .....	17
Table 5. N4693A 2-Port Electronic Calibration Module.....	19
<b>Uncorrected System Performance.....</b>	<b>21</b>
Table 6a. Directivity, All Options, All Ports (dB).....	21
Table 6b. Source Match (dB) .....	22
Table 6c. Load Match (dB).....	23
Table 6d. Reflection Tracking, Transmission Tracking, Crosstalk (dB), All Options, All Ports - Typical .....	23
.....	
Table 6e. Noise Mode <sup>1</sup> Uncorrected System Performance (dB), Option 029 - Specification .....	24
Table 6f. Noise Mode <sup>1</sup> Uncorrected System Performance (dB), Option 029 - Typical .....	24
<b>Test Port Output .....</b>	<b>25</b>
Table 7. Frequency Information, All Options .....	25
Table 8a. Maximum Leveled Power (dBm), Options 200 or 400 .....	26
Table 8b. Maximum Leveled Power (dBm), Options 219 or 419 .....	27
Table 8c. Maximum Leveled Power (dBm), Options 224 or 423 .....	28
Table 8d. Maximum Leveled Power (dBm), Options 224 or 423, Combine Mode - Typical .....	29
Table 8e. Maximum Leveled Power (dBm), Option 224.....	30
Table 8f. Maximum Leveled Power (dBm), Options 224 or 423 with 029 <sup>1</sup> .....	31
Table 8g. Maximum Leveled Power (dBm), Options 224 or 423 with 029 <sup>1</sup> , Combine Mode - Typical	32
Table 8h. Maximum Leveled Power (dBm), Noise Mode <sup>1</sup> , Options 224 or 423 with 029 <sup>1</sup> - Typical	33
Table 9. Power Level Accuracy (dB) at Nominal Power <sup>1</sup> , All Options .....	34
Table 10a. Power Level Linearity <sup>1</sup> (dB), All Options - Specification .....	34
Table 10b. Power Level Linearity <sup>1</sup> (dB), All Options - Specification.....	34
Table 10c. Power Level Linearity <sup>1</sup> (dB), Option 224 - Specification.....	34
Table 11a. Power Sweep Range (dB), Options 200 or 400.....	35
Table 11b. Power Sweep Range (dB), Options 219 or 419 .....	36
Table 11c. Power Sweep Range (dB), Options 224 or 423.....	37
Table 11d. Power Sweep Range (dB), Option 224 .....	38
Table 11e. Power Sweep Range (dB), Options 224 or 423 with 029 <sup>1</sup> .....	39

Table 12. Nominal Power (Preset Power, dBm).....	39
Table 13. Power Resolution and Maximum/Minimum Settable Power, All Ports <sup>1</sup> .....	40
Table 14. 2 <sup>nd</sup> and 3 <sup>rd</sup> Harmonics at Max Specified Power (dBc), All Options - Typical.....	40
Table 15. Non-Harmonic Spurs at Nominal Power (dBc), All Options - Typical.....	40
Table 16. Phase Noise (dBc/Hz), All Options, All Ports - Typical.....	41
<b>Test Port Input.....</b>	<b>42</b>
Table 17. Noise Floor <sup>1</sup> (dBm) @ 10 Hz IFBW, All Options, All Ports.....	42
Table 18. 0.1 dB Compression at Test Port (dBm), All Options, All Ports - Typical.....	42
Table 19. Receiver Compression Test Port Power <sup>1</sup> (dBm), All Ports - Specification.....	43
Table 20a. Trace Noise <sup>1</sup> Magnitude (dB rms), All Options, All Ports.....	43
Table 20b. Trace Noise <sup>1</sup> Phase (deg rms), All Options, All Ports.....	44
Table 21. Reference Level - Specification.....	44
Table 22. Stability <sup>1</sup> - Typical.....	44
Table 23. Damage Input Level - Specification.....	45
<b>Noise Receiver Input (Option 029 only).....</b>	<b>46</b>
Table 24. Noise Receiver Bandwidth.....	46
Table 25. Receiver Noise Figure (dB), Port 2, at 4 MHz BW, High Gain Setting.....	46
Table 26. Noise Figure Trace Noise <sup>1</sup> (dB rms) at 4 MHz BW, All Gain Settings.....	46
Table 27. Noise Receiver Linearity (dB) at 4 MHz BW - Specification.....	46
Table 28. Noise Receiver Input Range - Specification.....	47
<b>Dynamic Accuracy.....</b>	<b>48</b>
Table 29. Dynamic Accuracy - Specification.....	48
Table 30. Test Port Input (Group Delay) <sup>1</sup> .....	52
<b>General Information.....</b>	<b>53</b>
Table 31. Miscellaneous Information.....	53
Table 32. Front Panel Information, All Options.....	53
Table 33. Rear Panel Information, All Options.....	54
Table 34. Analyzer Dimensions and Weight.....	58
Regulatory and Environmental Information.....	58
<b>Measurement Throughput Summary.....</b>	<b>59</b>
Table 35a. Cycle Time (ms) for Measurement Completion, All Models, All Options - Typical.....	59
Table 35b. N5244A Cycle Time (ms) for Full-Span Measurement Completion - Typical.....	60
Table 35c. N5245A Cycle Time (ms) for Full-Span Measurement Completion - Typical.....	60
Table 36. Cycle Time vs. IF Bandwidth - Typical.....	61
Table 37. Cycle Time (ms) vs. Number of Points - Typical.....	62
Table 38. Data Transfer Time <sup>1</sup> (ms) - Typical.....	63
<b>Front-Panel Jumpers.....</b>	<b>64</b>
Table 39. Measurement Receiver Inputs (dBm) - Typical.....	64
Table 40a. Reference Receiver Inputs and Reference Source Outputs (dBm) - Typical.....	65
Table 40b. Reference Receiver Inputs and Reference Source Outputs (dBm) - Typical.....	66
Table 40c. Reference Receiver Inputs and Reference Source Outputs (dBm) - Typical.....	67
Table 41a. Source Outputs (dBm) - Typical.....	68

Table 41b. Source Outputs (dBm) - Typical .....	69
Table 42. Coupler Inputs (dB) - Typical .....	70
Table 43. Damage Level - Typical .....	70
<b>Test Set Block Diagrams.....</b>	<b>71</b>
Figure 1. 2-Port N5244A and N5245A Base Unit Option 200 .....	71
Figure 2. 2-Port N5244A and N5245A Option 219.....	71
Figure 3. 2-Port N5244A and N5245A Option 224.....	72
Figure 4. 2-Port N5244A and N5245A Option 224 with 029 .....	72
Figure 5. 4-Port N5244A and N5245A Base Unit - Option 400 .....	73
Figure 6. 4-Port N5244A and N5245A Option 419.....	73
Figure 7. 4-Port N5244A and N5245A Option 423.....	74
Figure 8. 4-Port N5244A and N5245A Option 423 with 029 .....	74
Figure 9. Receiver Block Diagram .....	75

**This is a complete list of the technical specifications for the N5244A and N5245A with the following options:**

**Option 029**, adds hardware and firmware for high-accuracy noise figure measurements. It requires one of Option 224 or 423. [See the block diagram.](#)

**Option 200**, 2-port standard test set (includes six front-panel access loops) and power range. [See the block diagram.](#)

**Option 219**, adds 2-port extended power range, source and receiver attenuators, and bias-tees (requires Option 200). [See the block diagram.](#)

**Option 224**, adds an internal second source, a combiner, and mechanical switches to the 2-port analyzer (requires Option 200, 219, and 080). [See the block diagram.](#)

**Option 400**, 4-port standard test set (includes twelve front-panel access loops), power range, and an internal second source (Option 080 recommended). [See the block diagram.](#)

**Option 419**, adds 4-port extended power range, source and receiver attenuators, and bias-tees (requires Option 400). [See the block diagram.](#)

**Option 423**, adds an internal combiner, and mechanical switches to the 4-port analyzer (requires Option 400, 419, and 080). [See the block diagram.](#)

#### Notes

Specifications for the N5244AS and N5245AS Option H85, when configured in standard configuration, are the same as those of closest N5244A and N5245A option configuration.

[The Corrected System Performance with Cal Kits](#) and [Dynamic Accuracy Charts](#) apply ONLY to N5244A/45A models with serial numbers starting with MY5244/45, SG5244/45, and US5244/45, and above. This document provides technical specifications for the 85056A calibration kit, and the N4693A 2-Port ECal module. Please download our free Uncertainty Calculator from [http://www.agilent.com/find/na\\_calculator](http://www.agilent.com/find/na_calculator) to generate the curves for your calibration kit and PNA setup.

For all tables in this data sheet, the specified performance at the exact frequency of a break is the degraded value of the two specifications at that frequency.

## Definitions

All specifications and characteristics apply over a 25 °C ±5 °C range (unless otherwise stated) and 90 minutes after the instrument has been turned on.

**Specification (spec.):** Warranted performance. Specifications include guardbands to account for the expected statistical performance distribution, measurement uncertainties, and changes in performance due to environmental conditions.

**Characteristic (char.):** A performance parameter that the product is expected to meet before it leaves the factory, but that is not verified in the field and is not covered by the product warranty. A characteristic includes the same guardbands as a specification.

**Typical (typ.):** Expected performance of an average unit which does not include guardbands. It is not covered by the product warranty.

**Nominal (nom.):** A general, descriptive term that does not imply a level of performance. It is not covered by the product warranty.

**Calibration:** The process of measuring known standards to characterize a network analyzer's systematic (repeatable) errors.

**Corrected (residual):** Indicates performance after error correction (calibration). It is determined by the quality of calibration standards and how well "known" they are, plus system repeatability, stability, and noise.

**Uncorrected (raw):** Indicates instrument performance without error correction. The uncorrected performance affects the stability of a calibration.

**Standard:** When referring to the analyzer, this includes no options unless noted otherwise.

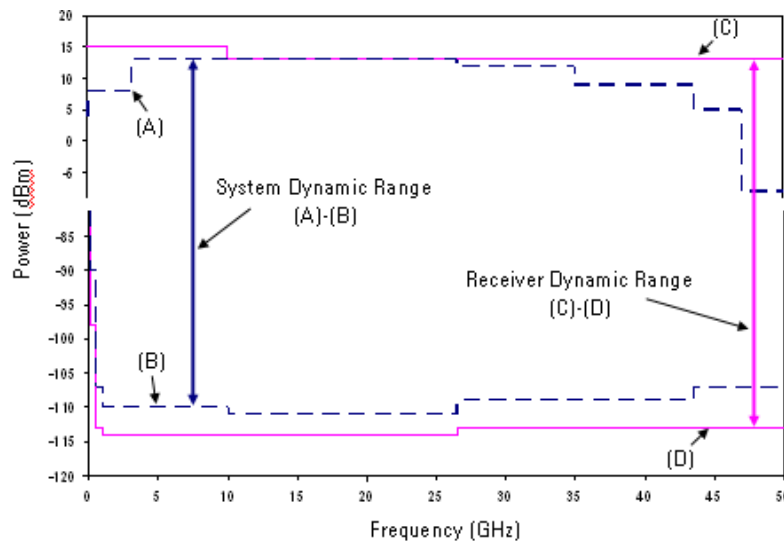
## Corrected System Performance

The specifications in this section apply for measurements made with the N5244A and N5245A analyzer with the following conditions:

- 10 Hz IF bandwidth
- No averaging applied to data
- Isolation calibration with an averaging factor of 8
- Source in filtered mode where applicable

## System Dynamic Range and Receiver Dynamic Range

- **System Dynamic Range** is defined as the maximum leveled output power (spec) minus the noise floor (spec).
- **Extended Dynamic Range at Direct Access Input** is defined as the maximum leveled output power (spec) minus the direct receiver access input noise floor (spec).
- **Receiver Dynamic Range** is defined as the test port compression at 0.1 dB (typical) minus the noise floor (typical).



### Note

The effective dynamic range must take measurement uncertainties and interfering signals into account. Direct receiver access should only be used when the receiver input will never exceed its maximum receiver input. When the analyzer is in segment sweep mode, it can have predefined frequency segments which will output a higher power level when the extended dynamic range is required (i.e. devices with high insertion loss), and reduced power when the maximum receiver input level will occur (i.e. devices with low insertion loss). The extended range is only available in one-path transmission measurements.

System dynamic range may typically be degraded at particular frequencies below 500 MHz due to spurious receiver residuals.

**Table 1. System Dynamic Range, Options 200 or 400, and Receiver Dynamic Range, All Options**

Description	Specification, Options 200, 400			Typical, All Options		
	System Dynamic Range (dB) (A)-(B)	Max Leveled Output Power (dBm) (A)	Test Port Noise Floor (dBm) (B)	Receiver Dynamic Range (dB) (C)-(D)	Test Port Compression at 0.1 dB (dBm) (C)	Test Port Noise Floor (dBm) (D)
	Ports 1, 3 <sup>1</sup>	Ports 1, 3 <sup>1</sup>	All	All	All	All
10 MHz to 50 MHz	74	4	-70	91	15	-76
50 MHz to 100 MHz	93	8	-85	106	15	-91
100 MHz to 500 MHz	98	8	-90	113	15	-98
500 MHz to 1 GHz	114	8	-106	127	15	-112
1 GHz to 2 GHz	118	8	-110	129	15	-114
2 GHz to 3.2 GHz	118	8	-110	129	15	-114
3.2 GHz to 10 GHz	123	13	-110	129	15	-114
10 GHz to 16 GHz	124	13	-111	127	13	-114
16 GHz to 20 GHz	124	13	-111	127	13	-114
20 GHz to 26.5 GHz	124	13	-111	127	13	-114
26.5 GHz to 30 GHz	120	12	-108	126	13	-113
30 GHz to 32 GHz	119	11	-108	126	13	-113
32 GHz to 35 GHz	120	12	-108	126	13	-113
35 GHz to 40 GHz	117	9	-108	126	13	-113
40 GHz to 43.5 GHz	118	9	-109	126	13	-113
43.5 GHz to 47 GHz	112	5	-107	126	13	-113
47 GHz to 50 GHz	102	-5	-107	126	13	-113

<sup>1</sup> Either port can be used as the source port. Any other port can be used as the receiver port.



**Table 2a. System Dynamic Range at Test Port (dB), Options 200 or 400**

Description	Specification		Typical	
	Ports 1, 3 <sup>1</sup>	Ports 2, 4 <sup>1</sup>	Ports 1, 3 <sup>1</sup>	Ports 2, 4 <sup>1</sup>
10 MHz to 50 MHz	74	82	88	95
50 MHz to 100 MHz	93	98	104	111
100 MHz to 500 MHz	98	103	111	118
500 MHz to 1 GHz	114	119	126	131
1 GHz to 2 GHz	118	123	128	133
2 GHz to 3.2 GHz	118	123	128	133
3.2 GHz to 10 GHz	123	123	133	133
10 GHz to 16 GHz	124	124	132	131
16 GHz to 20 GHz	124	124	131	131
20 GHz to 26.5 GHz	124	124	131	131
26.5 GHz to 30 GHz	120	120	130	130
30 GHz to 32 GHz	119	119	129	129
32 GHz to 35 GHz	120	120	130	130
35 GHz to 40 GHz	117	117	126	126
40 GHz to 43.5 GHz	118	118	126	126
43.5 GHz to 47 GHz	112	112	124	124
47 GHz to 50 GHz	102	102	115	115

<sup>1</sup> Either port can be used as the source port. Any other port can be used as the receiver port.

**Table 2b. System Dynamic Range at Test Port (dB), Options 219 or 419**

Description	Specification		Typical (dB)	
	Ports 1, 3 <sup>1</sup>	Ports 2, 4 <sup>1</sup>	Ports 1, 3 <sup>1</sup>	Ports 2, 4 <sup>1</sup>
10 MHz to 50 MHz	74	82	89	95
50 MHz to 100 MHz	93	98	104	111
100 MHz to 500 MHz	98	103	111	118
500 MHz to 1 GHz	114	119	126	132
1 GHz to 2 GHz	118	123	126	133
2 GHz to 3.2 GHz	118	123	129	131
3.2 GHz to 10 GHz	123	123	132	132
10 GHz to 16 GHz	122	122	130	130
16 GHz to 20 GHz	121	121	129	129
20 GHz to 26.5 GHz	121	121	129	129
26.5 GHz to 30 GHz	117	117	128	128
30 GHz to 32 GHz	115	115	126	126
32 GHz to 35 GHz	117	117	127	127
35 GHz to 40 GHz	112	112	122	122
40 GHz to 43.5 GHz	113	113	122	122
43.5 GHz to 47 GHz	106	106	119	119
47 GHz to 50 GHz	96	96	108	108

<sup>1</sup> Either port can be used as the source port. Any other port can be used as the receiver port.

**Table 2c. System Dynamic Range at Test Port (dB), Option 224**

Description	Specification		Typical (dB)	
	Source 2 Out 1	Source 2 Out 2	Source 2 Out 1	Source 2 Out 2
10 MHz to 50 MHz	74	83	89	95
50 MHz to 100 MHz	93	100	104	111
100 MHz to 500 MHz	98	105	111	118
500 MHz to 1 GHz	114	119	126	132
1 GHz to 2 GHz	118	123	127	134
2 GHz to 3.2 GHz	118	123	127	132
3.2 GHz to 10 GHz	124	126	134	134
10 GHz to 16 GHz	123	124	133	132
16 GHz to 20 GHz	125	125	133	133
20 GHz to 26.5 GHz	125	125	133	133
26.5 GHz to 30 GHz	122	122	132	132
30 GHz to 32 GHz	121	122	131	132
32 GHz to 35 GHz	122	122	132	132
35 GHz to 40 GHz	119	120	128	129
40 GHz to 43.5 GHz	120	121	128	129
43.5 GHz to 47 GHz	114	115	126	127
47 GHz to 50 GHz	105	105	118	121

**Table 2d. System Dynamic Range at Test Port (dB), Options 224 or 423**

Description	Specification		Typical			
	Ports 1, 3 <sup>1</sup>	Ports 2, 4 <sup>1</sup>	Ports 1, 3 <sup>1</sup>	Ports 2, 4 <sup>1</sup>	Source 1 Port 1 Combine Mode	Source 2 Port 1 Combine Mode
10 MHz to 50 MHz	74	80	89	95	82	83
50 MHz to 100 MHz	93	98	104	111	97	97
100 MHz to 500 MHz	98	103	111	118	104	104
500 MHz to 1 GHz	114	119	125	131	118	118
1 GHz to 2 GHz	118	123	126	132	120	120
2 GHz to 3.2 GHz	118	123	126	131	120	121
3.2 GHz to 10 GHz	123	123	132	132	124	123
10 GHz to 16 GHz	122	122	130	129	121	121
16 GHz to 20 GHz	121	121	128	128	117	117
20 GHz to 26.5 GHz	121	121	128	128	117	117
26.5 GHz to 30 GHz	117	117	127	127	114	113
30 GHz to 32 GHz	115	115	126	126	114	113
32 GHz to 35 GHz	117	117	126	126	114	113
35 GHz to 40 GHz	112	112	122	121	110	108
40 GHz to 43.5 GHz	113	113	122	121	110	108
43.5 GHz to 47 GHz	105	105	119	119	107	103
47 GHz to 50 GHz	95	95	109	110	96	92

<sup>1</sup> Either port can be used as the source port. Any other port can be used as the receiver port.

**Table 2e. System Dynamic Range at Test Port (dB), Options 224 or 423 with 029<sup>1</sup>**

Description	Specification		Typical			
	Port 1	Port 2	Port 1	Port 2	Source 1 Port 1 Combine Mode	Source 2 Port 1 Combine Mode
10 MHz to 50 MHz	74	80	87	95	80	81
50 MHz to 100 MHz	93	98	102	110	95	95
100 MHz to 500 MHz	98	103	109	117	102	102
500 MHz to 1 GHz	114	119	122	128	116	116
1 GHz to 2 GHz	118	123	124	130	118	118
2 GHz to 3.2 GHz	118	123	124	130	118	118
3.2 GHz to 10 GHz	123	123	130	130	122	121
10 GHz to 16 GHz	121	121	127	127	118	118
16 GHz to 20 GHz	119	119	127	127	116	116
20 GHz to 26.5 GHz	119	119	127	127	116	116
26.5 GHz to 30 GHz	115	115	126	126	114	113
30 GHz to 32 GHz	113	113	124	124	114	113
32 GHz to 35 GHz	115	115	126	126	114	113
35 GHz to 40 GHz	109	109	121	121	109	108
40 GHz to 43.5 GHz	110	110	121	121	109	108
43.5 GHz to 47 GHz	103	103	117	118	105	103
47 GHz to 50 GHz	92	92	106	107	93	89

<sup>1</sup> Option 029 affects system dynamic range with port 1 or port 2 as the source port. Refer to Table 2c and 2d for the system dynamic range with port 3 or port 4 as the source port. Port 1 impedance tuner switch is in bypass position and port 2 noise receiver switch is in normal position.

**Table 3a. Extended Dynamic Range at Direct Receiver Access Input (dB) - Specification**

Description	Options 200, 400		Options 219, 419	
	Ports 1, 3 <sup>1</sup>	Ports 2, 4 <sup>1</sup>	Ports 1, 3 <sup>1</sup>	Ports 2, 4 <sup>1</sup>
10 MHz to 50 MHz	109	117	109	117
50 MHz to 100 MHz	113	118	113	118
100 MHz to 500 MHz	118	123	118	123
500 MHz to 1 GHz	135	140	135	140
1 GHz to 2 GHz	138	143	138	143
2 GHz to 3.2 GHz	130	135	130	135
3.2 GHz to 10 GHz	135	135	135	135
10 GHz to 16 GHz	136	136	134	134
16 GHz to 20 GHz	136	136	133	133
20 GHz to 26.5 GHz	136	136	133	133
26.5 GHz to 30 GHz	130	130	127	127
30 GHz to 32 GHz	129	129	125	125
32 GHz to 35 GHz	130	130	127	127
35 GHz to 40 GHz	127	127	122	122
40 GHz to 43.5 GHz	128	128	123	123
43.5 GHz to 47 GHz	122	122	116	116
47 GHz to 50 GHz	112	112	106	106

<sup>1</sup>Either port can be used as the source port. Any other port can be used as the receiver port.

**Table 3b. Extended Dynamic Range at Direct Receiver Access Input (dB), Options 224 or 423**

Description	Specification				Typical	
	Option 224		Options 224, 423		Options 224, 423	
	Source 2 Out 1	Source 2 Out 2	Ports 1, 3 <sup>1</sup>	Ports 2, 4 <sup>1</sup>	Source 1 Port 1 Combine Mode	Source 2 Port 1 Combine Mode
10 MHz to 50 MHz	109	118	109	115	117	118
50 MHz to 100 MHz	113	120	113	118	117	117
100 MHz to 500 MHz	118	125	118	123	124	124
500 MHz to 1 GHz	135	140	135	140	139	139
1 GHz to 2 GHz	138	143	138	143	140	140
2 GHz to 3.2 GHz	130	135	130	135	132	133
3.2 GHz to 10 GHz	136	138	135	135	136	135
10 GHz to 16 GHz	135	136	134	134	133	133
16 GHz to 20 GHz	137	137	133	133	129	129
20 GHz to 26.5 GHz	137	137	133	133	129	129
26.5 GHz to 30 GHz	132	132	127	127	124	123
30 GHz to 32 GHz	131	132	125	125	124	123
32 GHz to 35 GHz	132	132	127	127	124	123
35 GHz to 40 GHz	129	130	122	122	120	118
40 GHz to 43.5 GHz	130	131	123	123	120	118
43.5 GHz to 47 GHz	124	125	115	115	117	113
47 GHz to 50 GHz	115	115	105	105	106	102

<sup>1</sup>Either port can be used as the source port. Any other port can be used as the receiver port.

**Table 3c. Extended Dynamic Range at Direct Receiver Access Input (dB), Options 224 or 423 with 029<sup>1</sup>**

Description	Specification		Typical	
	Port 1	Port 2	Source 1 Port 1 Combine Mode	Source 2 Port 1 Combine Mode
10 MHz to 50 MHz	109	115	115	116
50 MHz to 100 MHz	113	118	115	115
100 MHz to 500 MHz	118	123	122	122
500 MHz to 1 GHz	135	140	137	137
1 GHz to 2 GHz	138	143	138	138
2 GHz to 3.2 GHz	130	135	130	130
3.2 GHz to 10 GHz	135	135	134	133
10 GHz to 16 GHz	133	133	130	130
16 GHz to 20 GHz	131	131	128	128
20 GHz to 26.5 GHz	131	131	128	128
26.5 GHz to 30 GHz	125	125	124	123
30 GHz to 32 GHz	123	123	124	123
32 GHz to 35 GHz	125	125	124	123
35 GHz to 40 GHz	119	119	119	118
40 GHz to 43.5 GHz	120	120	119	118
43.5 GHz to 47 GHz	113	113	115	113
47 GHz to 50 GHz	102	102	103	99

<sup>1</sup> Option 029 affects system dynamic range with port 1 or port 2 as the source port. Refer to Table 3b for the extended dynamic range with port 3 or port 4 as the source port. Port 1 impedance tuner switch is in bypass position and port 2 noise receiver switch is in normal position.



## N5244A and N5245A Corrected System Performance, All Options

Note: For any  $S_{ii}$  reflection measurement:

- $S_{jj} = 0$ .

For any  $S_{ij}$  transmission measurement:

- $S_{ji} = S_{ij}$  when  $S_{ij} \leq 1$
- $S_{ji} = 1/S_{ij}$  when  $S_{ij} > 1$
- $S_{kk} = 0$  for all  $k$

Applies to the N5244A and N5245A Option 200 or 219 or 224 or 400 or 419 or 423 analyzers with serial numbers listed below, 85056A (2.4 mm) calibration kit, 85133F flexible test port cable set, and a full 2-port calibration.

N5244A: MY5244/SG5244/US5244 and above

N5244AS: MY5249/SG5249/US5249 and above

N5245A: MY5245/SG5245/US5245 and above

N5245AS: MY5250/SG5250/US5250 and above

Also applies to the following condition: environmental temperature  $23^\circ \pm 3^\circ \text{C}$ , with  $< 1^\circ \text{C}$  deviation from calibration temperature. The uncertainty charts were generated for Option 423, although they are applicable for any option without Option 029. Please download our free Uncertainty Calculator from [http://www.agilent.com/find/na\\_calculator](http://www.agilent.com/find/na_calculator) to generate the curves for your calibration kit and PNA setup.

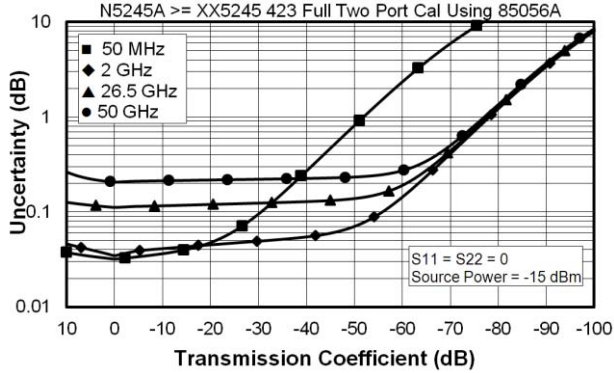
**Table 4. 85056A Calibration Kit**

Description	Specification (dB)						
	10 MHz to 50 MHz	50 MHz to 2 GHz	2 GHz to 10 GHz	10 GHz to 20 GHz	20 GHz to 30 GHz	30 GHz to 40 GHz	40 GHz to 50 GHz
Directivity	42	42	42	42	38	38	36
Source Match	41	41	38	38	33	33	31
Load Match	42	42	42	42	37	37	35
Reflection Tracking <sup>1</sup>							
Mag	$\pm 0.001$	$\pm 0.001$	$\pm 0.008$	$\pm 0.008$	$\pm 0.020$	$\pm 0.020$	$\pm 0.027$
Phase ( $^\circ$ )	$\pm 0.009$	$\pm 0.009$	$\pm 0.054$	$\pm 0.054$	$\pm 0.133$	$\pm 0.133$	$\pm 0.180$
Transmission Tracking without Option 029							
Mag	$\pm 0.045$	$\pm 0.024$	$\pm 0.039$	$\pm 0.045$	$\pm 0.138$	$\pm 0.138$	$\pm 0.182$
Phase ( $^\circ$ )	$\pm 0.300$	$\pm 0.155$	$\pm 0.255$	$\pm 0.297$	$\pm 0.912$	$\pm 0.912$	$\pm 1.202$
$S_{21}$ Transmission Tracking with Option 029 <sup>1</sup>							
Mag	$\pm 0.045$	$\pm 0.028$	$\pm 0.047$	$\pm 0.051$	$\pm 0.138$	$\pm 0.138$	$\pm 0.196$
Phase ( $^\circ$ )	$\pm 0.300$	$\pm 0.182$	$\pm 0.308$	$\pm 0.335$	$\pm 0.912$	$\pm 0.912$	$\pm 1.292$
$S_{12}$ Transmission Tracking with Option 029 <sup>1</sup>							
Mag	$\pm 0.045$	$\pm 0.028$	$\pm 0.047$	$\pm 0.051$	$\pm 0.138$	$\pm 0.138$	$\pm 0.196$
Phase ( $^\circ$ )	$\pm 0.300$	$\pm 0.182$	$\pm 0.308$	$\pm 0.335$	$\pm 0.912$	$\pm 0.912$	$\pm 1.292$

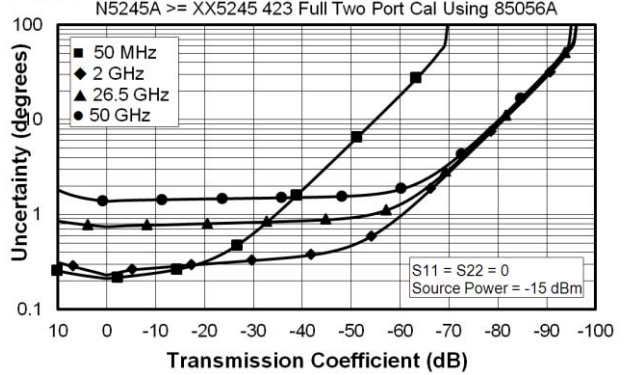
<sup>1</sup> The port 1 noise tuner switch set to the bypass position, and port 2 noise receiver switch set to the normal position.

## Transmission Uncertainty

### Magnitude

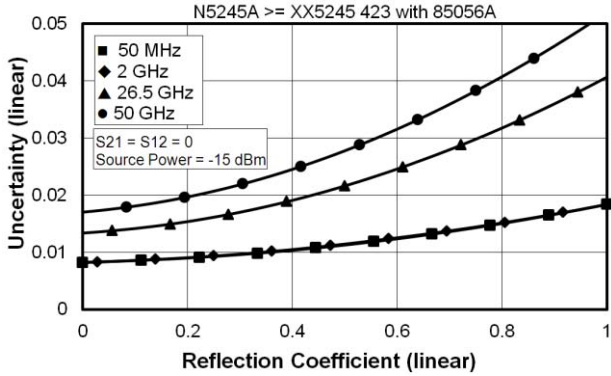


### Phase

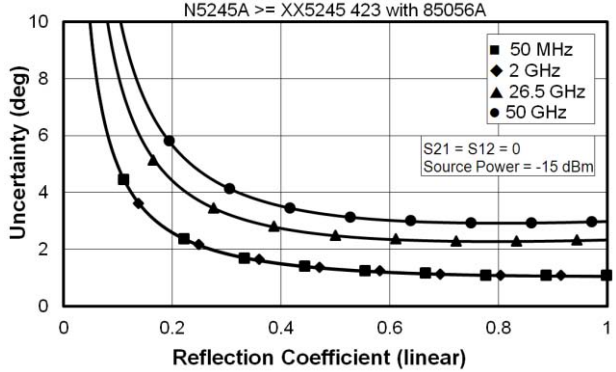


## Reflection Uncertainty

### Magnitude



### Phase



**Table 5. N4693A 2-Port Electronic Calibration Module**

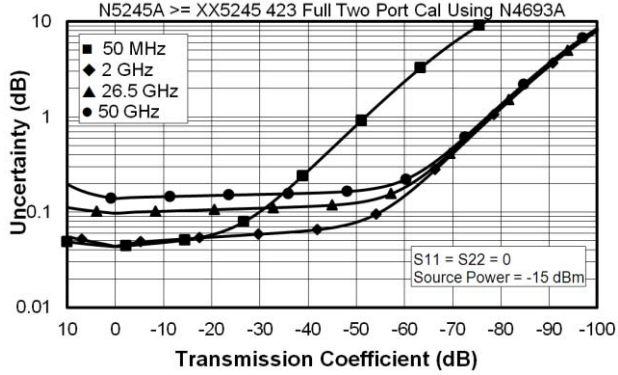
Description	Specification (dB)						
	10 MHz to 50 MHz	50 MHz to 2 GHz	2 GHz to 10 GHz	10 GHz to 20 GHz	20 GHz to 30 GHz	30 GHz to 40 GHz	40 GHz to 50 GHz
Directivity	32	55	49	45	43	43	41
Source Match	25	46	42	37	35	35	30
Load Match	25	45	41	36	34	34	29
Reflection Tracking <sup>1</sup>							
Mag	±0.050	±0.030	±0.040	±0.050	±0.060	±0.060	±0.080
Phase (°)	±0.330	±0.198	±0.264	±0.330	±0.396	±0.396	±0.528
Transmission Tracking without Option 029							
Mag	±0.118	±0.033	±0.047	±0.064	±0.087	±0.087	±0.114
Phase (°)	±0.781	±0.218	±0.309	±0.420	±0.576	±0.576	±0.754
S <sub>21</sub> Transmission Tracking with Option 029 <sup>1</sup>							
Mag	±0.118	±0.033	±0.049	±0.064	±0.087	±0.087	±0.114
Phase (°)	±0.781	±0.221	±0.321	±0.420	±0.576	±0.576	±0.754
S <sub>12</sub> Transmission Tracking with Option 029 <sup>1</sup>							
Mag	±0.118	±0.033	±0.049	±0.064	±0.087	±0.087	±0.118
Phase (°)	±0.781	±0.221	±0.321	±0.420	±0.576	±0.576	±0.781

<sup>1</sup> Temperature deviation is a characteristic value.

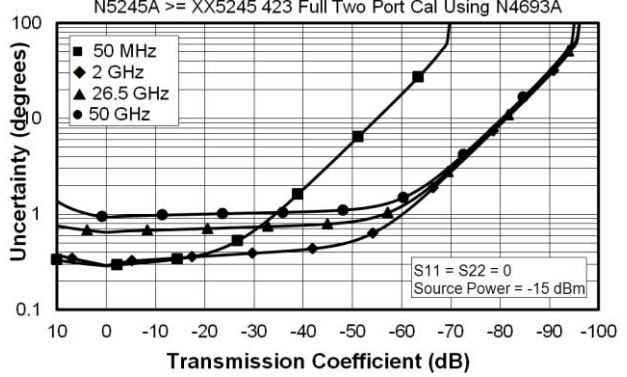
<sup>2</sup> The port 1 noise tuner switch set to the internal position, and port 2 noise receiver switch set to the normal position.

## Transmission Uncertainty

### Magnitude

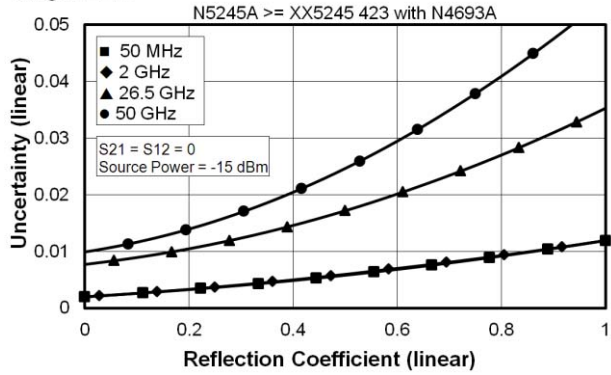


### Phase

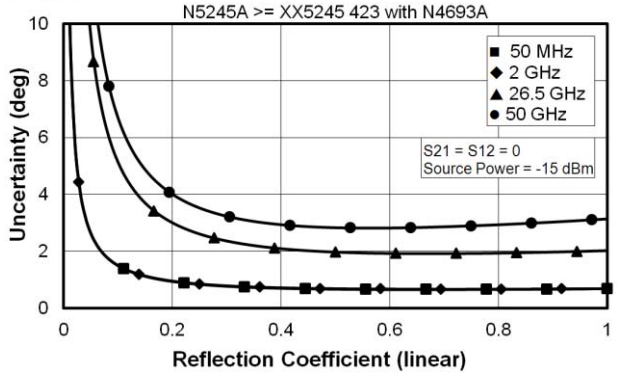


## Reflection Uncertainty

### Magnitude



### Phase



## Uncorrected System Performance

Specifications apply to following conditions:

- Over environmental temperature of 25 °C ±5 °C, with less than 1°C variation from the calibration temperature.
- Cable loss not included in Transmission Tracking.
- Crosstalk measurement conditions: normalized to a thru, measured with shorts on all ports, 10 Hz IF bandwidth, averaging factor of 8, alternate mode, source power set to the specified maximum power.
- With option 029, port 1 impedance tuner switch is in bypass position and port 2 noise receiver switch is in normal position unless specified. Refer to Options 200, 219, 224, 400, 419, 423 for Option 029 Ports 3 and 4 performances.

**Table 6a. Directivity, All Options, All Ports (dB)**

Description	Specification	Typical
10 MHz to 50 MHz	18	21
50 MHz to 200 MHz	22	27
200 MHz to 500 MHz	23	27
500 MHz to 3.2 GHz	23	30
3.2 GHz to 10 GHz	22	25
10 GHz to 13.5 GHz	18	23
13.5 GHz to 16 GHz	18	21
16 GHz to 20 GHz	18	20
20 GHz to 24 GHz	16	20
24 GHz to 35 GHz	16	22
35 GHz to 43.5 GHz	16	21
43.5 GHz to 47 GHz	15	21
47 GHz to 50 GHz	15	19

**Table 6b. Source Match (dB)**

Description	Specification		Typical	
	Options 200, 219, 224, 400, 419, 423	Option 029	Options 200, 219, 224, 400, 419, 423	Option 029
	All Ports	Ports 1, 2	All Ports	Ports 1, 2
10 MHz to 50 MHz	10	10	13	13
50 MHz to 200 MHz	18	18	27	27
200 MHz to 500 MHz	16	18	21	27
500 MHz to 3.2 GHz	14	16	20	21
3.2 GHz to 10 GHz	12	13	17	20
10 GHz to 13.5 GHz	12	12	17	17
13.5 GHz to 16 GHz	12	12	18	17
16 GHz to 20 GHz	11	11	16	18
20 GHz to 24 GHz	11	10	17	16
24 GHz to 26.5 GHz	11	9	12	15
26.5 GHz to 35 GHz	7	7	12	12
35 GHz to 43.5 GHz	7	7	13	12
43.5 GHz to 46 GHz	6	7	13	13
46 GHz to 47 GHz	6	6	11	11
47 GHz to 50 GHz	10	6	13	11

**Table 6c. Load Match (dB)**

Description	Specification		Typical	
	Options 200, 219, 224, 400, 419, 423	Option 029	Options 200, 219, 224, 400, 419, 423	Option 029
	All Ports	Ports 1, 2	All Ports	Ports 1, 2
10 MHz to 50 MHz	10	10	15	15
50 MHz to 200 MHz	16	16	22	22
200 MHz to 500 MHz	14	16	18	22
500 MHz to 3.2 GHz	13	13	17	18
3.2 GHz to 10 GHz	11	11	16	17
10 GHz to 13.5 GHz	11	11	15	16
13.5 GHz to 16 GHz	11	11	16	15
16 GHz to 20 GHz	10	11	16	16
20 GHz to 24 GHz	10	8	16	16
24 GHz to 26.5 GHz	10	8	12	16
26.5 GHz to 46 GHz	7	7	12	12
46 GHz to 47 GHz	7	6	11	11
47 GHz to 50 GHz	10	6	15	11

**Table 6d. Reflection Tracking, Transmission Tracking, Crosstalk (dB), All Options, All Ports - Typical**

Description	Reflection Tracking	Transmission Tracking	Cross-talk
10 MHz to 50 MHz	±1.5	±1.5	-82
50 MHz to 100 MHz	±1.5	±1.5	-85
100 MHz to 500 MHz	±1.5	±1.5	-110
500 MHz to 26.5 GHz	±1.5	±1.5	-120
26.5 GHz to 35 GHz	±1.5 <sup>1</sup>	±1.5	-120
35 GHz to 43.5 GHz	±1.5 <sup>1</sup>	±1.5	-115
43.5 GHz to 46 GHz	±1.5	±1.5	-115
46 GHz to 47 GHz	±1.5	±1.5	-105
46 GHz to 50 GHz	±1.5	±1.5	-100

<sup>1</sup> Reflection tracking from 26.5 GHz to 43.5 GHz with Option 029 is degraded to +1.5/-7.

**Table 6e. Noise Mode<sup>1</sup> Uncorrected System Performance (dB), Option 029 - Specification**

Description	Source Match		Load Match	
	Port 1	Port 2	Port 1	Port 2
10 MHz to 50 MHz	4	5	4	5
50 MHz to 200 MHz	9	17	10	16
200 MHz to 500 MHz	9	17	10	16
500 MHz to 3.2 GHz	10	16	10	14
3.2 GHz to 10 GHz	10	14	9	13
10 GHz to 16 GHz	10	12	9	11
16 GHz to 20 GHz	8	10	9	10
20 GHz to 24 GHz	8	8	9	8
24 GHz to 26.5 GHz	8	8	9	6
26.5 GHz to 50 GHz	6	6	6	6

<sup>1</sup> Noise mode sets port 1 impedance tuner switch to tuner position and port 2 noise receiver switch to noise receiver position.

**Table 6f. Noise Mode<sup>1</sup> Uncorrected System Performance (dB), Option 029 - Typical**

Description	Source Match		Load Match		Reflection Tracking		Transmission Tracking
	Port 1	Port 2	Port 1	Port 2	Port 1	Port 2	Ports 1, 2
10 MHz to 50 MHz	5	7	6	6	-1.5/-6	±2.5	±1.5
50 MHz to 500 MHz	12	25	12	22	-1.5/-6	±1.5	±1.5
500 MHz to 3.2 GHz	12	21	12	18	-1.5/-6	±1.5	±1.5
3.2 GHz to 10 GHz	14	20	14	17	-1.5/-6	±1.5	±1.5
10 GHz to 13.5 GHz	15	17	15	16	-1.5/-6	±1.5	±1.5
13.5 GHz to 16 GHz	19	17	15	15	-1.5/-6	±1.5	±1.5
16 GHz to 20 GHz	17	18	16	16	-4/-10	±1.5	±1.5
20 GHz to 24 GHz	16	16	16	16	-4/-10	±1.5	±1.5
24 GHz to 26.5 GHz	15	15	16	15	-4/-10	±1.5	±1.5
26.5 GHz to 43.5 GHz	12	12	12	12	-4/-8	±2.5	±1.5
43.5 GHz to 46 GHz	13	13	12	12	-6/-9	±3	±1.5
46 GHz to 50 GHz	11	11	11	11	-6/-9	±3	±1.5

<sup>1</sup> Noise mode sets port 1 impedance tuner switch to tuner position and port 2 noise receiver switch to noise receiver position.



## Test Port Output

See Block diagrams for all models and options beginning on page 71.

With option 029, port 1 tuner switch is in bypass position and port 2 noise receiver switch is in normal position unless specified.

**Table 7. Frequency Information, All Options**

Description	Specification	Typical
N5244A Frequency Range	10 MHz to 43.5 GHz	--
N5245A Frequency Range	10 MHz to 50.0 GHz	--
Frequency Resolution	1 Hz	--
Frequency Accuracy	$\pm 1$ ppm	--
Frequency Stability	--	$\pm 0.05$ ppm, $-10^{\circ}$ to $70^{\circ}$ C <sup>1</sup> $\pm 0.1$ ppm/yr maximum <sup>2</sup>

<sup>1</sup> Assumes no variation in time.

<sup>2</sup> Assumes no variation in temperature.

**Table 8a. Maximum Leveled Power (dBm), Options 200 or 400**

Description	Specification			Typical		
	Ports 1, 3 <sup>1</sup>		Ports 2, 4 <sup>1</sup>	Ports 1, 3 <sup>1</sup>		Ports 2, 4 <sup>1</sup>
	Filtered Mode <sup>2</sup>	Hi Power Mode <sup>2</sup>		Filtered Mode <sup>2</sup>	Hi Power Mode <sup>2</sup>	
10 MHz to 50 MHz	4	12	12	12	20	19
50 MHz to 500 MHz	8	13	13	13	20	20
500 MHz to 1 GHz	8	13	13	14	19	19
1 GHz to 2 GHz	8	13	13	14	17	19
2 GHz to 3.2 GHz	8	10	13	14	15	19
3.2 GHz to 10 GHz	13	13	13	19	19	19
10 GHz to 16 GHz	13	13	13	18	18	17
16 GHz to 26.5 GHz	13	13	13	17	17	17
26.5 GHz to 30 GHz	12	12	12	17	17	17
30 GHz to 32 GHz	11	11	11	16	16	16
32 GHz to 35 GHz	12	12	12	17	17	17
35 GHz to 43.5 GHz	9	9	9	13	13	13
43.5 GHz to 47 GHz	5	5	5	11	11	11
47 GHz to 50 GHz	-5	-5	-5	2	2	2

<sup>1</sup> Either port can be used as the source port.

<sup>2</sup> In Filtered Mode, the signal path goes through filters to minimize harmonics below 3.2 GHz. In Hi Power Mode, the signal bypasses the filters to maximize output power.

**Table 8b. Maximum Leveled Power (dBm), Options 219 or 419**

Description	Specification			Typical		
	Ports 1, 3 <sup>1</sup>		Ports 2, 4 <sup>1</sup>	Ports 1, 3 <sup>1</sup>		Ports 2, 4 <sup>1</sup>
	Filtered Mode <sup>2</sup>	Hi Power Mode <sup>2</sup>		Filtered Mode <sup>2</sup>	Hi Power Mode <sup>2</sup>	
10 MHz to 50 MHz	4	9	12	13	20	19
50 MHz to 500 MHz	8	13	13	13	20	20
500 MHz to 1 GHz	8	13	13	14	19	20
1 GHz to 2 GHz	8	12	13	12	17	19
2 GHz to 3.2 GHz	8	10	13	15	15	17
3.2 GHz to 10 GHz	13	13	13	18	18	18
10 GHz to 16 GHz	11	11	11	16	16	16
16 GHz to 26.5 GHz	10	10	10	15	15	15
26.5 GHz to 30 GHz	9	9	9	15	15	15
30 GHz to 32 GHz	7	7	7	13	13	13
32 GHz to 35 GHz	9	9	9	14	14	14
35 GHz to 43.5 GHz	4	4	4	9	9	9
43.5 GHz to 47 GHz	-1	-1	-1	6	6	6
47 GHz to 50 GHz	-11	-11	-11	-5	-5	-5

<sup>1</sup> Either port can be used as the source port.

<sup>2</sup> In Filtered Mode, the signal path goes through filters to minimize harmonics below 3.2 GHz. In Hi Power Mode, the signal bypasses the filters to maximize output power.

**Table 8c. Maximum Leveled Power (dBm), Options 224 or 423**

Description	Specification			Typical		
	Ports 1, 3 <sup>1</sup>		Ports 2, 4 <sup>1</sup>	Ports 1, 3 <sup>1</sup>		Ports 2, 4 <sup>1</sup>
	Filtered Mode <sup>2</sup>	Hi Power Mode <sup>2</sup>		Filtered Mode <sup>2</sup>	Hi Power Mode <sup>2</sup>	
10 MHz to 50 MHz	4	11	10	13	20	19
50 MHz to 500 MHz	8	13	13	13	20	20
500 MHz to 1 GHz	8	13	13	13	18	19
1 GHz to 2 GHz	8	13	13	12	17	18
2 GHz to 3.2 GHz	8	10	13	12	14	17
3.2 GHz to 10 GHz	13	13	13	18	18	18
10 GHz to 16 GHz	11	11	11	16	16	15
16 GHz to 26.5 GHz	10	10	10	14	14	14
26.5 GHz to 30 GHz	9	9	9	14	14	14
30 GHz to 32 GHz	7	7	7	13	13	13
32 GHz to 35 GHz	9	9	9	13	13	13
35 GHz to 43.5 GHz	4	4	4	9	9	8
43.5 GHz to 47 GHz	-2	-2	-2	6	6	6
47 GHz to 50 GHz	-12	-12	-12	-4	-4	-3

<sup>1</sup> Either port can be used as the source port.

<sup>2</sup> In Filtered Mode, the signal path goes through filters to minimize harmonics below 3.2 GHz. In Hi Power Mode, the signal bypasses the filters to maximize output power.

**Table 8d. Maximum Leveled Power (dBm), Options 224 or 423, Combine Mode - Typical**

Description	Source 1 Port 1		Source 2 Port 1	
	Filtered Mode <sup>1</sup>	Hi Power Mode <sup>1</sup>	Filtered Mode <sup>1</sup>	Hi Power Mode <sup>1</sup>
10 MHz to 50 MHz	6	13	7	13
50 MHz to 1 GHz	6	11	6	11
1 GHz to 2 GHz	6	10	6	9
2 GHz to 3.2 GHz	6	6	7	6
3.2 GHz to 10 GHz	10	10	9	9
10 GHz to 16 GHz	7	7	7	7
16 GHz to 26.5 GHz	3	3	3	3
26.5 GHz to 35 GHz	1	1	0	0
35 GHz to 43.5 GHz	-3	-3	-5	-5
43.5 GHz to 47 GHz	-6	-6	-10	-10
47 GHz to 50 GHz	-17	-17	-21	-21

<sup>1</sup> In Filtered Mode, the signal path goes through filters to minimize harmonics below 3.2 GHz. In Hi Power Mode, the signal bypasses the filters to maximize output power.

**Table 8e. Maximum Leveled Power (dBm), Option 224**

Description	Specification			Typical		
	Source 2 Out 1		Source 2 Out 2	Source 2 Out 1		Source 2 Out 2
	Filtered Mode <sup>1</sup>	Hi Power Mode <sup>1</sup>		Filtered Mode <sup>1</sup>	Hi Power Mode <sup>1</sup>	
10 MHz to 50 MHz	4	13	13	13	20	19
50 MHz to 500 MHz	8	18	15	13	20	20
500 MHz to 1 GHz	8	16	13	14	19	20
1 GHz to 2 GHz	8	13	13	13	18	20
2 GHz to 3.2 GHz	8	11	13	13	16	18
3.2 GHz to 10 GHz	14	14	16	20	20	20
10 GHz to 16 GHz	12	12	13	19	19	18
16 GHz to 26.5 GHz	14	14	14	19	19	19
26.5 GHz to 30 GHz	14	14	14	19	19	19
30 GHz to 32 GHz	13	13	14	18	18	19
32 GHz to 35 GHz	14	14	14	19	19	19
35 GHz to 43.5 GHz	11	11	12	15	15	16
43.5 GHz to 47 GHz	7	7	8	13	13	14
47 GHz to 50 GHz	-2	-2	-2	5	5	8

<sup>1</sup> In Filtered Mode, the signal path goes through filters to minimize harmonics below 3.2 GHz. In Hi Power Mode, the signal bypasses the filters to maximize output power.

**Table 8f. Maximum Leveled Power (dBm), Options 224 or 423 with 029<sup>1</sup>**

Description	Specification			Typical		
	Port 1		Port 2	Port 1		Port 2
	Filtered Mode <sup>2</sup>	Hi Power Mode <sup>2</sup>		Filtered Mode <sup>2</sup>	Hi Power Mode <sup>2</sup>	
10 MHz to 50 MHz	4	11	10	11	18	19
50 MHz to 500 MHz	8	13	13	11	18	19
500 MHz to 1 GHz	8	13	13	10	18	16
1 GHz to 2 GHz	8	13	13	10	16	16
2 GHz to 3.2 GHz	8	10	13	10	13	16
3.2 GHz to 10 GHz	13	13	13	16	16	16
10 GHz to 16 GHz	10	10	10	13	13	13
16 GHz to 26.5 GHz	8	8	8	13	13	13
26.5 GHz to 30 GHz	7	7	7	13	13	13
30 GHz to 32 GHz	5	5	5	11	11	11
32 GHz to 35 GHz	7	7	7	13	13	13
35 GHz to 43.5 GHz	1	1	1	8	8	8
43.5 GHz to 47 GHz	-4	-4	-4	4	4	5
47 GHz to 50 GHz	-15	-15	-15	-7	-7	-6

<sup>1</sup> Option 029 affects port 1 and port 2 maximum leveled power. Refer to Table 8c and 8e for other ports.

<sup>2</sup> In Filtered Mode, the signal path goes through filters to minimize harmonics below 3.2 GHz. In Hi Power Mode, the signal bypasses the filters to maximize output power.

**Table 8g. Maximum Leveled Power (dBm), Options 224 or 423 with 029<sup>1</sup>, Combine Mode - Typical**

Description	Source 1 Port 1		Source 2 Port 1	
	Filtered Mode <sup>2</sup>	Hi Power Mode <sup>2</sup>	Filtered Mode <sup>2</sup>	Hi Power Mode <sup>2</sup>
10 MHz to 50 MHz	4	11	5	11
50 MHz to 1 GHz	4	11	4	11
1 GHz to 2 GHz	4	9	4	8
2 GHz to 3.2 GHz	4	5	4	5
3.2 GHz to 10 GHz	8	8	7	7
10 GHz to 16 GHz	4	4	4	4
16 GHz to 26.5 GHz	2	2	2	2
26.5 GHz to 35 GHz	1	1	0	0
35 GHz to 43.5 GHz	-4	-4	-5	-5
43.5 GHz to 47 GHz	-8	-8	-10	-10
47 GHz to 50 GHz	-20	-20	-24	-24

<sup>1</sup> Option 029 affects port 1 and port 2 maximum leveled power. Refer to Table 8c and 8e for other ports.

<sup>2</sup> In Filtered Mode, the signal path goes through filters to minimize harmonics below 3.2 GHz. In Hi Power Mode, the signal bypasses the filters to maximize output power.



**Table 8h. Maximum Leveled Power (dBm), Noise Mode<sup>1</sup>, Options 224 or 423 with 029<sup>1</sup> - Typical**

Description	Port 1				Source 2 Port 1		Port 2
	Normal Mode		Combine Mode		Combine Mode		
	Filtered Mode <sup>2</sup>	Hi Power Mode <sup>2</sup>	Filtered Mode <sup>2</sup>	Hi Power Mode <sup>2</sup>	Filtered Mode <sup>2</sup>	Hi Power Mode <sup>2</sup>	
10 MHz to 50 MHz	5	12	-2	5	-1	5	6
50 MHz to 500 MHz	7	14	0	7	0	7	10
500 MHz to 1 GHz	6	14	0	7	0	7	7
1 GHz to 2 GHz	6	12	0	5	0	4	7
2 GHz to 3.2 GHz	6	9	0	1	0	1	6
3.2 GHz to 10 GHz	11	11	3	3	2	2	6
10 GHz to 16 GHz	7	7	-2	-2	-2	-2	3
16 GHz to 26.5 GHz	6	6	-5	-5	-5	-5	2
26.5 GHz to 30 GHz	7	7	-5	-5	-6	-6	-7
30 GHz to 32 GHz	4	4	-6	-6	-7	-7	1
32 GHz to 35 GHz	6	6	-6	-6	-7	-7	-7
35 GHz to 43.5 GHz	1	1	-11	-11	-12	-12	-2
43.5 GHz to 47 GHz	-4	-4	-16	-16	-18	-18	-4
47 GHz to 50 GHz	-15	-15	-28	-28	-32	-32	-16

<sup>1</sup> Noise mode sets port 1 tuner switch to tuner position and port 2 noise receiver switch to noise receiver position.

<sup>2</sup> In Filtered Mode, the signal path goes through filters to minimize harmonics below 3.2 GHz. In Hi Power Mode, the signal bypasses the filters to maximize output power.

**Table 9. Power Level Accuracy (dB) at Nominal Power<sup>1</sup>, All Options**

Description	Specification		Typical	
	Ports 1, 2, 3, 4 <sup>2</sup>	Source 2 Out 1 Source 2 Out 2	Ports 1, 2, 3, 4 <sup>2</sup>	Source 2 Out 1 Source 2 Out 2
10 MHz to 50 MHz	± 1.0	± 2.0	± 0.27	± 0.30
50 MHz to 1 GHz	± 1.0	± 2.0	± 0.24	± 0.26
1 GHz to 3.2 GHz	± 1.2	± 2.0	± 0.33	± 0.20
3.2 GHz to 13.5 GHz	± 1.5	± 2.0	± 0.33	± 0.20
13.5 GHz to 20 GHz	± 1.5	± 2.5	± 0.36	± 0.52
20 GHz to 26.5 GHz	± 2.0	± 2.5	± 0.47	± 0.44
26.5 GHz to 43.5 GHz	± 3.0	± 3.5	± 0.25	± 0.27
43.5 GHz to 50 GHz	± 3.5	± 3.5	± 0.97	± 0.82

<sup>1</sup> Level accuracy at power other than nominal power, Power Level Accuracy (dB) at Nominal Power + Power Level Linearity (dB)

<sup>2</sup> Any port can be used as the source port. Source in filtered mode where applicable.

**Table 10a. Power Level Linearity<sup>1</sup> (dB), All Options - Specification**

Description	Ports 1, 3 <sup>2</sup>	Ports 1, 3 <sup>2</sup>	Ports 1, 3 <sup>2</sup>
	-25 dBm ≤ P < -20 dBm	-20 dBm ≤ P < -15 dBm	P ≥ -15 dBm
10 MHz to 50 GHz	± 1.5	± 1.5	± 1.5

<sup>1</sup> Referenced to nominal power.

<sup>2</sup> Either port can be used as the source port. Source in filtered mode.

**Table 10b. Power Level Linearity<sup>1</sup> (dB), All Options - Specification**

Description	Ports 2, 4 <sup>2</sup>	Ports 2, 4 <sup>2</sup>	Ports 2, 4 <sup>2</sup>
	-25 dBm ≤ P < -20 dBm	-20 dBm ≤ P < -15 dBm	P ≥ -15 dBm
10 MHz to 50 GHz	± 2.0	± 1.5	± 1.5

<sup>1</sup> Referenced to nominal power.

<sup>2</sup> Either port can be used as the source port.

**Table 10c. Power Level Linearity<sup>1</sup> (dB), Option 224 - Specification**

Description	Source 2 Out 1 <sup>2</sup>	Source 2 Out 2	Source 2 Out 2
	P ≥ -15 dBm	-15 dBm ≤ P < -10 dBm	P ≥ -10 dBm
10 MHz to 50 GHz	± 1.0	± 1.0	± 1.0

<sup>1</sup> Referenced to nominal power.

<sup>2</sup> Source in filtered mode.

**Table 11a. Power Sweep Range (dB), Options 200 or 400**

Description	Specification		Typical	
	Ports 1, 3 <sup>1</sup>	Ports 2, 4 <sup>1</sup>	Ports 1, 3 <sup>1</sup>	Ports 2, 4 <sup>1</sup>
10 MHz to 50 MHz	37	37	47	46
50 MHz to 500 MHz	38	38	47	47
500 MHz to 1 GHz	38	38	46	46
1 GHz to 2 GHz	38	38	44	46
2 GHz to 3.2 GHz	35	38	42	46
3.2 GHz to 10 GHz	38	38	46	46
10 GHz to 16 GHz	38	38	45	44
16 GHz to 26.5 GHz	38	38	43	44
26.5 GHz to 30 GHz	37	37	44	44
30 GHz to 32 GHz	36	36	43	43
32 GHz to 35 GHz	37	37	44	44
35 GHz to 43.5 GHz	34	34	40	40
43.5 GHz to 47 GHz	30	30	38	38
47 GHz to 50 GHz	20	20	29	29

<sup>1</sup> Either port can be used as the source port. Source in Hi Power mode where applicable.

**Table 11b. Power Sweep Range (dB), Options 219 or 419**

Description	Specification		Typical	
	Ports 1, 3 <sup>1</sup>	Ports 2, 4 <sup>1</sup>	Ports 1, 3 <sup>1</sup>	Ports 2, 4 <sup>1</sup>
10 MHz to 50 MHz	34	37	47	46
50 MHz to 500 MHz	38	38	47	47
500 MHz to 1 GHz	38	38	46	47
1 GHz to 2 GHz	37	38	44	46
2 GHz to 3.2 GHz	35	38	42	44
3.2 GHz to 10 GHz	38	38	45	45
10 GHz to 16 GHz	36	36	43	43
16 GHz to 26.5 GHz	35	35	42	42
26.5 GHz to 30 GHz	34	34	42	42
30 GHz to 32 GHz	32	32	40	40
32 GHz to 35 GHz	34	34	41	41
35 GHz to 43.5 GHz	29	29	36	36
43.5 GHz to 47 GHz	24	24	33	33
47 GHz to 50 GHz	14	14	22	22

<sup>1</sup> Either port can be used as the source port. Source in Hi Power mode where applicable.

**Table 11c. Power Sweep Range (dB), Options 224 or 423**

Description	Specification		Typical	
	Ports 1, 3 <sup>1</sup>	Ports 2, 4 <sup>1</sup>	Ports 1, 3 <sup>1</sup>	Ports 2, 4 <sup>1</sup>
10 MHz to 50 MHz	36	35	47	46
50 MHz to 500 MHz	38	38	47	47
500 MHz to 1 GHz	38	38	45	46
1 GHz to 2 GHz	38	38	44	45
2 GHz to 3.2 GHz	35	38	41	44
3.2 GHz to 10 GHz	38	38	45	45
10 GHz to 16 GHz	36	36	43	42
16 GHz to 26.5 GHz	35	35	41	41
26.5 GHz to 30 GHz	34	34	41	41
30 GHz to 32 GHz	32	32	40	40
32 GHz to 35 GHz	34	34	40	40
35 GHz to 43.5 GHz	29	29	36	35
43.5 GHz to 47 GHz	23	23	33	33
47 GHz to 50 GHz	13	13	23	24

<sup>1</sup> Either port can be used as the source port. Source in Hi Power mode where applicable.

**Table 11d. Power Sweep Range (dB), Option 224**

Description	Specification		Typical	
	Source 2 Out 1 <sup>1</sup>	Source 2 Out 2	Source 2 Out 1 <sup>1</sup>	Source 2 Out 2
10 MHz to 50 MHz	28	28	37	36
50 MHz to 500 MHz	33	30	37	37
500 MHz to 1 GHz	31	28	36	37
1 GHz to 2 GHz	28	28	35	37
2 GHz to 3.2 GHz	26	28	33	35
3.2 GHz to 10 GHz	29	31	37	37
10 GHz to 16 GHz	27	28	36	35
16 GHz to 26.5 GHz	29	29	36	36
26.5 GHz to 30 GHz	29	29	36	36
30 GHz to 32 GHz	28	29	35	36
32 GHz to 35 GHz	29	29	36	36
35 GHz to 43.5 GHz	26	27	32	33
43.5 GHz to 47 GHz	22	23	30	31
47 GHz to 50 GHz	13	13	22	25

<sup>1</sup>Source in Hi Power mode where applicable.

**Table 11e. Power Sweep Range (dB), Options 224 or 423 with 029<sup>1</sup>**

Description	Specification		Typical	
	Port 1 <sup>2</sup>	Port 2	Port 1 <sup>2</sup>	Port 2
10 MHz to 50 MHz	36	35	45	46
50 MHz to 500 MHz	38	38	45	46
500 MHz to 1 GHz	38	38	45	43
1 GHz to 2 GHz	38	38	43	43
2 GHz to 3.2 GHz	35	38	40	43
3.2 GHz to 10 GHz	38	38	43	43
10 GHz to 16 GHz	35	35	40	40
16 GHz to 26.5 GHz	33	33	40	40
26.5 GHz to 30 GHz	30	32	40	40
30 GHz to 32 GHz	30	30	38	38
32 GHz to 35 GHz	32	32	40	40
35 GHz to 43.5 GHz	26	26	35	35
43.5 GHz to 47 GHz	21	21	31	32
47 GHz to 50 GHz	10	10	20	21

<sup>1</sup> Option 029 affects port 1 and port 2 power sweep ranges. Refer to Table 10c and 10d for other ports.

<sup>2</sup> Source in Hi Power mode where applicable.

**Table 12. Nominal Power (Preset Power, dBm)**

Description	Specification			Typical	
	All Options	Option 224		Options 224, 423	
	Ports 1, 2, 3, 4 <sup>1</sup>	Source 2 Out 1	Source 2 Out 2	Source 1 Port 1 Combine Mode	Source 2 Port 1 Combine Mode
N5244A	-5	-5	-5	-15	-15
N5245A	-15	-5	-5	-25	-30

<sup>1</sup> Any port can be used as the source port.

**Table 13. Power Resolution and Maximum/Minimum Settable Power, All Ports<sup>1</sup>**

Description	Specification (dB)	Typical (dBm)		
		All Options	Options 200, 400	Options 219, 419, 224, 423
Power Resolution	0.01	--	--	--
Maximum Settable Power	--	30	--	--
Minimum Settable Power	--	--	-30	-90

<sup>1</sup> Any port can be used as the source port.

**Table 14. 2<sup>nd</sup> and 3<sup>rd</sup> Harmonics at Max Specified Power (dBc), All Options - Typical**

Description <sup>1</sup>	Ports 1, 3 <sup>2</sup> , Source 2 Out 1 <sup>3</sup>	Ports 2, 4 <sup>2</sup> , Source 2 Out 2
10 MHz to 2 GHz	-51	-13
2 GHz to 13.5 GHz	-60	-21
13.5 GHz to 50 GHz	-60	-60

<sup>1</sup> Listed frequency is fundamental frequency; test at max specified power

<sup>2</sup> Any port can be used as the source port. Source in Filtered mode where applicable.

<sup>3</sup> At port 1 max specified power.

**Table 15. Non-Harmonic Spurs at Nominal Power (dBc), All Options - Typical**

Description	Ports 1, 2, 3, 4, Source 2 Out 1, Source 2 Out 2
10 MHz to 500 MHz	-50
500 MHz to 2GHz	-60
2 GHz to 4 GHz	-57
4 GHz to 8 GHz	-51
8 GHz to 16 GHz	-45
16 GHz to 32 GHz	-39
32 GHz to 50 GHz	-31



**Table 16. Phase Noise (dBc/Hz), All Options, All Ports - Typical**

<b>Description</b>	<b>1 kHz Offset</b>	<b>10 kHz Offset</b>	<b>100 kHz Offset</b>	<b>1 MHz Offset</b>
10 MHz to 500 MHz	-85	-85	-85	-120
500 MHz to 1 GHz	-105	-115	-110	-127
1 GHz to 2 GHz	-100	-110	-105	-121
2 GHz to 4 GHz	-95	-105	-100	-115
4 GHz to 8 GHz	-89	-100	-94	-110
8 GHz to 16 GHz	-83	-94	-88	-105
16 GHz to 32 GHz	-77	-88	-82	-99
32 GHz to 50 GHz	-71	-82	-76	-93

## Test Port Input

**Table 17. Noise Floor<sup>1</sup> (dBm) @ 10 Hz IFBW, All Options, All Ports**

Description	Specification		Typical	
	Test Port	Direct Receiver Access Input	Test Port	Direct Receiver Access Input
10 MHz to 50 MHz <sup>2</sup>	-70	-105	-76	-111
50 MHz to 100 MHz <sup>2</sup>	-85	-105	-91	-111
100 MHz to 500 MHz <sup>2</sup>	-90	-110	-98	-118
500 MHz to 1 GHz	-106	-127	-112	-133
1 GHz to 2 GHz	-110	-130	-114	-134
2 GHz to 10 GHz	-110	-122	-114	-126
10 GHz to 26.5 GHz	-111	-123	-114	-126
26.5 GHz to 40 GHz	-108	-118	-113	-123
40 GHz to 43.5 GHz	-109	-119	-113	-123
43.5 GHz to 50 GHz	-107	-117	-113	-123

<sup>1</sup> Total average (rms) noise power calculated as the mean value of a linear magnitude trace expressed in dBm.

<sup>2</sup> May typically be degraded at particular frequencies below 500 MHz due to spurious receiver residuals.

**Table 18. 0.1 dB Compression at Test Port (dBm), All Options, All Ports - Typical**

Description	Typical
10 MHz to 10 GHz	15
10 GHz to 50 GHz	13

**Table 19. Receiver Compression Test Port Power<sup>1</sup> (dBm), All Ports - Specification**

Description	Test Port Power			Receiver compression	
	Options 200, 400	Options 219, 419	Options 224, 423	Magnitude (dB)	Phase (degree)
500 MHz to 10 GHz	13	13	13	0.15	1.5
10 GHz to 13.5 GHz	13	11	10	0.15	1.5
13.5 GHz to 20 GHz	13	9	9	0.15	1.5
20 GHz to 26.5 GHz	13	9	9	0.18	1.5
26.5 GHz to 32 GHz	13	9	8	0.18	1.5
32 GHz to 40 GHz	9	8	8	0.18	1.5
40 GHz to 43.5 GHz	8	8	8	0.18	1.5
43.5 GHz to 45 GHz	8	8	8	0.2	1.5
45 GHz to 47 GHz	6	6	6	0.2	1.5
47 GHz to 50 GHz	5	1	0	0.2	1.5

<sup>1</sup> Test port receiver compression at input levels below 500 MHz is negligible due to coupler roll off.

**Table 20a. Trace Noise<sup>1</sup> Magnitude (dB rms), All Options, All Ports**

Description	Specification	Typical		
	1 kHz IFBW	1 kHz IFBW	100 kHz IFBW	600 kHz IFBW
10 MHz to 50 MHz	0.200	0.08	0.800	2.000
50 MHz to 100 MHz	0.020	0.013	0.120	0.300
100 MHz to 500 MHz	0.020	0.005	0.050	0.150
500 MHz to 1 GHz	0.003	0.002	0.012	0.030
1 GHz to 26.5 GHz	0.002	0.002	0.011	0.026
26.5 GHz to 43.5 GHz	0.003	0.002	0.011	0.026
43.5 GHz to 50 GHz	0.004	0.002	0.011	0.026

<sup>1</sup> Ratioed measurement, nominal power at test port.

**Table 20b. Trace Noise<sup>1</sup> Phase (deg rms), All Options, All Ports**

Description	Specification	Typical		
		1 kHz IFBW	100 kHz IFBW	600 kHz IFBW
10 MHz to 50 MHz	1	0.6	6	14
50 MHz to 100 MHz	1	0.1	1	1.8
100 MHz to 500 MHz	0.5	0.035	0.35	1.0
500 MHz to 1 GHz	0.02	0.009	0.1	0.25
1 GHz to 26.5 GHz	0.02	0.009	0.08	0.18
26.5 GHz to 50 GHz	0.03	0.015	0.09	0.2

<sup>1</sup> Ratioed measurement, nominal power at test port.

**Table 21. Reference Level - Specification**

Description	Magnitude (dB)	Phase (°)
Range	±500	±500
Resolution	0.001	0.01

**Table 22. Stability<sup>1</sup> - Typical**

Description	Magnitude (dB/°C)	Phase (°/°C)
10 MHz to 50 MHz	0.02	0.3
50 MHz to 3.2 GHz	0.01	0.15
3.2 GHz to 10 GHz	0.01	0.2
10 GHz to 16 GHz	0.01	0.25
16 GHz to 20 GHz	0.015	0.3
20 GHz to 26.5 GHz	0.015	0.4
26.5 GHz to 32 GHz	0.02	0.55
32 GHz to 40 GHz	0.025	0.7
40 GHz to 47 GHz	0.025	0.75
47 GHz to 50 GHz	0.03	0.8

<sup>1</sup> Stability is defined as a ratio measurement made at the test port.

**Table 23. Damage Input Level - Specification**

<b>Description</b>	<b>RF (dBm)</b>	<b>DC (V)</b>
Test Ports 1, 2, 3, 4	> +30	40
Source 2 Out 1, Source 2 Out 2 (Option 224 only)	> +30	0
Test Port 1, Noise Mode <sup>1</sup> (Option 029 only)	> +10	40
Test Port 2, Noise Mode <sup>1</sup> (Option 029 only)	> +27	40

<sup>1</sup> Noise mode sets port 1 impedance tuner switch to internal tuner position and port 2 noise receiver switch to noise receiver position.

## Noise Receiver Input (Option 029 only)

**Table 24. Noise Receiver Bandwidth**

Description	Allowable Bandwidths
10 MHz to 25 MHz	800 kHz, 2 MHz
25 MHz to 60 MHz	800 kHz, 2/4 MHz
60 MHz to 150 MHz	800 kHz, 2/4/8 MHz <sup>1</sup>
150 MHz to 50 GHz	800 kHz, 2/4/8/24 MHz <sup>1</sup>

<sup>1</sup> 8 and 24 MHz bandwidths are available only with calibration using noise source.

**Table 25. Receiver Noise Figure (dB), Port 2, at 4 MHz BW, High Gain Setting**

Description	Specification	Typical
10 MHz to 50 MHz	--	9
50 MHz to 1.5 GHz	10	7
1.5 GHz to 5 GHz	12	10
5 GHz to 20 GHz	15	11
20 GHz to 45 GHz	16	11
45 GHz to 50 GHz	21	14

**Table 26. Noise Figure Trace Noise<sup>1</sup> (dB rms) at 4 MHz BW, All Gain Settings**

Frequency	Specification	Typical
10 MHz to 50 MHz	--	0.07
50 MHz to 50 GHz	0.11	0.07

<sup>1</sup> Trace noise magnitude performance on noise figure trace or sometimes called noise jitter, 201 points, 1 noise average, with terminated input. May typically be degraded at frequencies below 500 MHz due to spurious noise receiver residuals.

**Table 27. Noise Receiver Linearity (dB) at 4 MHz BW - Specification**

Power Range (dBm)			Specification
Low Gain Setting Reference to -60dBm	Medium Gain Setting Reference to -70 dBm	High Gain Setting Reference to -80 dBm	
-36 to -64	-48 to -76	-58 to -85	±0.05
-64 to -70	-76 to -87	-85 to -92	±0.07

**Table 28. Noise Receiver Input Range - Specification**

Description	Max DUT NF + Gain (dB) <sup>1</sup>			Max Input Power (dBm) for <0.1 dB Compression <sup>2</sup>		
	High Gain Setting	Medium Gain Setting	Low Gain Setting	High Gain Setting	Medium Gain Setting	Low Gain Setting
500 MHz to 4.5 GHz	37	53	68	<=-51	<=-35	<=-20
4.5 GHz to 6 GHz	38	53	71	<=-50	<=-35	<=-17
6 GHz to 24 GHz	47	57	66	<=-41	<=-31	<=-22
24 GHz to 26.5 GHz	45	58	66	<=-43	<=-30	<=-22
26.5 GHz to 36 GHz	45	56	57	<=-43	<=-32	<=-31
36 GHz to 50 GHz	39	51	58	<=-49	<=-37	<=-30

<sup>1</sup> Limited by 0.1 dB receiver compression. Applies to devices with bandwidth <400 MHz. For devices with higher bandwidths, calculate the DUT output noise power as  $-174 \text{ dBm} + 10 \cdot \log_{10}(B) + \text{Gain (dB)} + \text{NF (dB)}$ , where B is the bandwidth of the DUT in Hz, and use the Max Input Power specification.

<sup>2</sup> Derived from ensuring < 0.25 dB compression with a CW signal 5 dB higher than the stated max input power value for 0.1 dB compression. Referenced to test port 2.

## Dynamic Accuracy

**Table 29. Dynamic Accuracy - Specification**

Standard receiver accuracy of the test port input power reading relative to the reference input power level. It is verified with the following measurements:

- Compression over frequency
- IF linearity at a single frequency of 1.998765 GHz using a reference level of -20 dBm for an input power range of 0 to -60 dBm. For value below -60 dBm, refer to "VNA Receiver Dynamic Accuracy Specifications and Uncertainties".

Applies N5244A and N5245A with following serial numbers.

N5244A: MY5244/SG5244/US5244 and above

N5244AS: MY5249/SG5249/US5249 and above

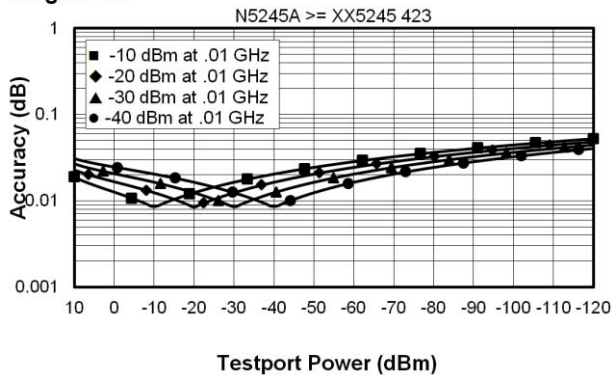
N5245A: MY5245/SG5245/US5245 and above

N5245AS: MY5250/SG5250/US5250 and above

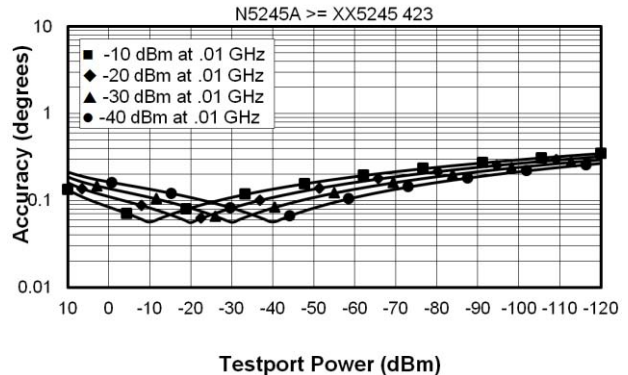
Please download our free Uncertainty Calculator from [http://www.agilent.com/find/na\\_calculator](http://www.agilent.com/find/na_calculator) to generate the curves for your PNA.

### Dynamic Accuracy, 0.010 GHz

#### Magnitude

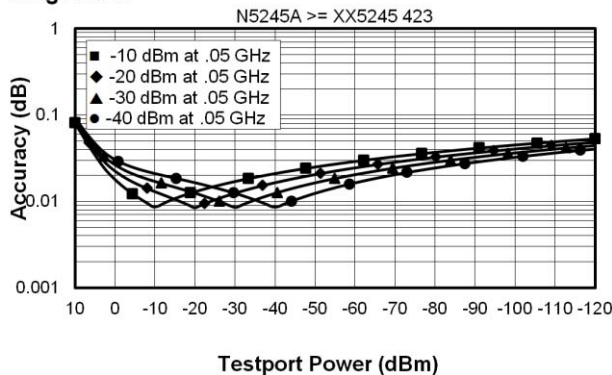


#### Phase

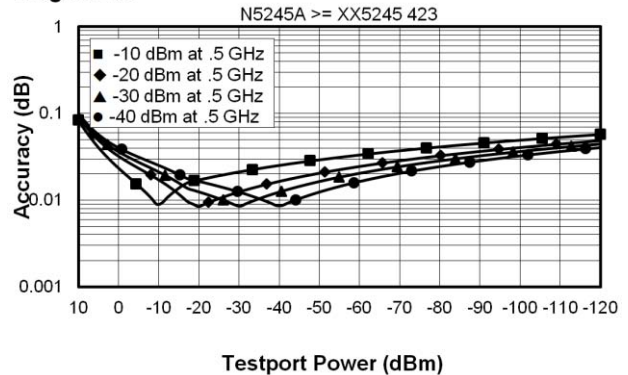


### Dynamic Accuracy, 0.050 GHz

#### Magnitude



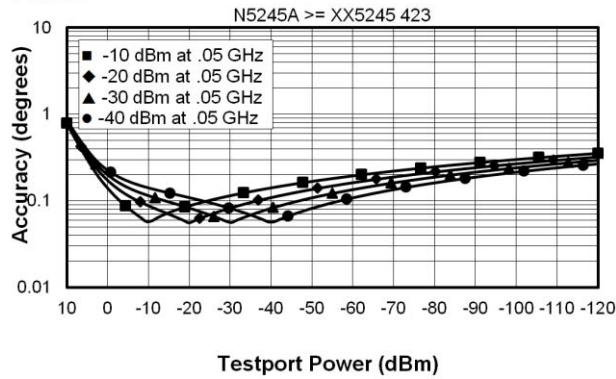
#### Magnitude



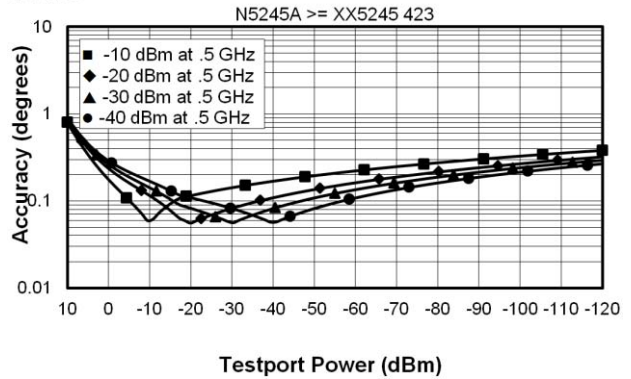


## Dynamic Accuracy, 0.500 GHz

Phase

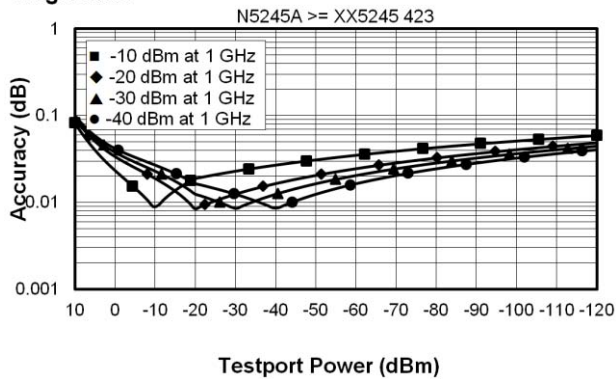


Phase

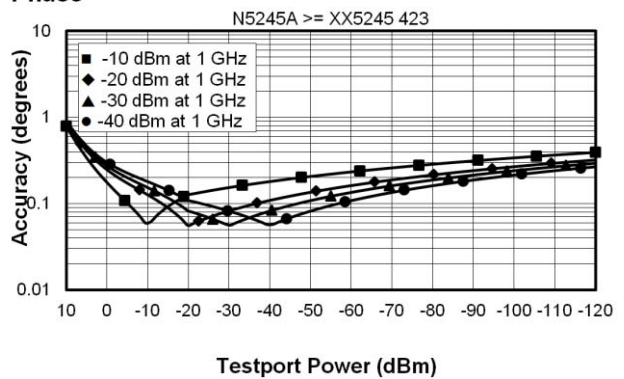


## Dynamic Accuracy, 1 GHz

Magnitude

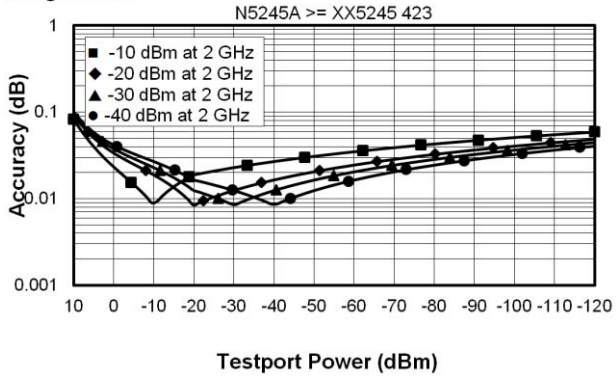


Phase

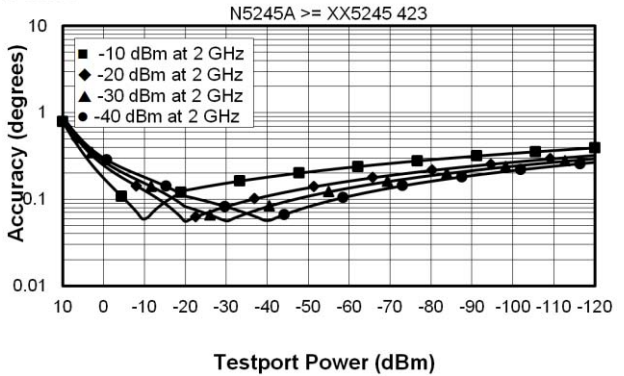


## Dynamic Accuracy, 2 GHz

Magnitude

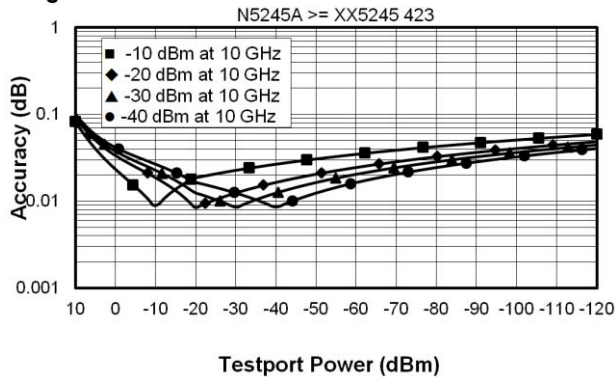


Phase

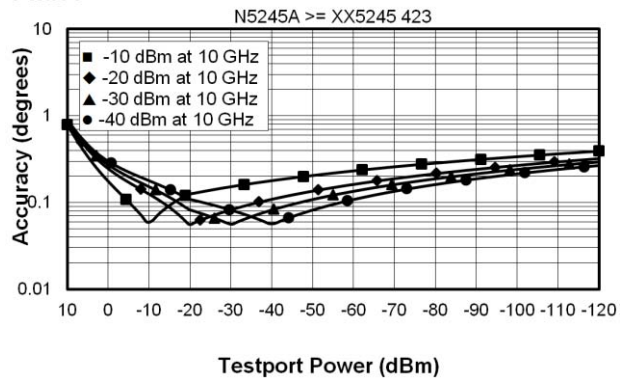


## Dynamic Accuracy, 10 GHz

### Magnitude

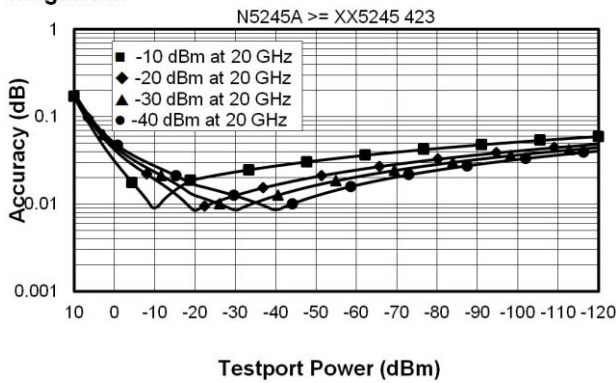


### Phase

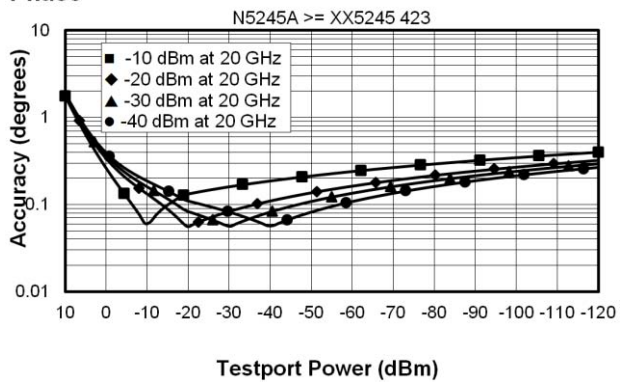


## Dynamic Accuracy, 20 GHz

### Magnitude

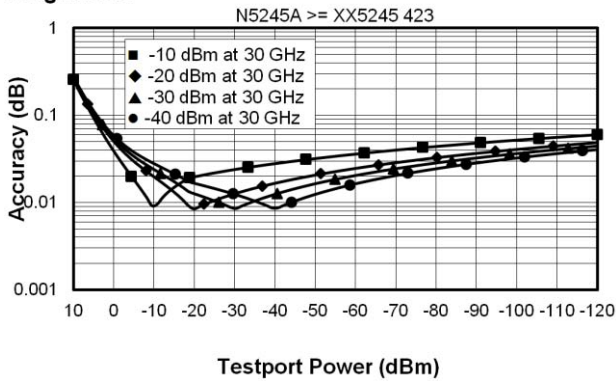


### Phase

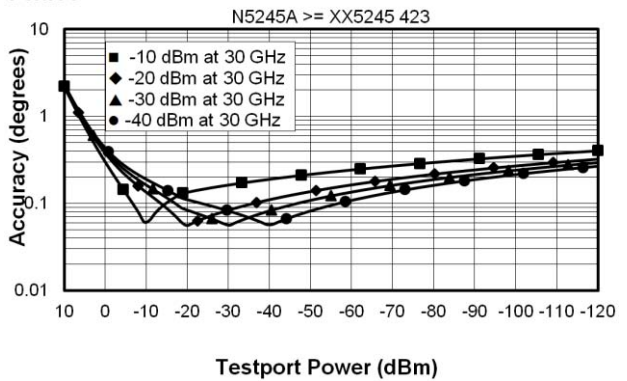


## Dynamic Accuracy, 30 GHz

### Magnitude

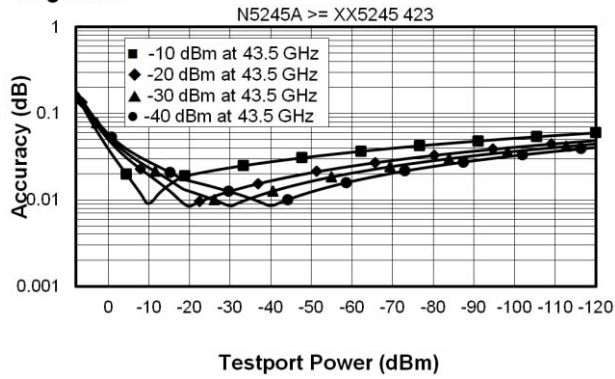


### Phase

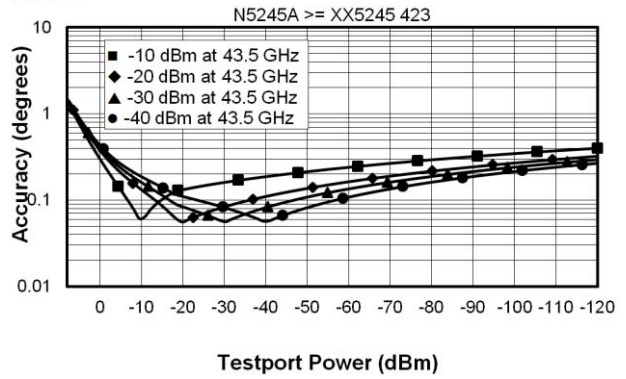


## Dynamic Accuracy, 43.5 GHz

Magnitude

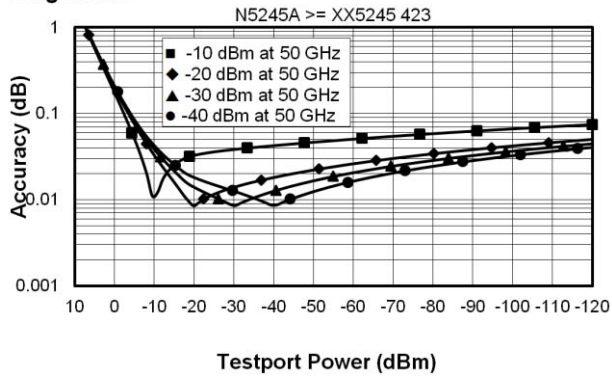


Phase

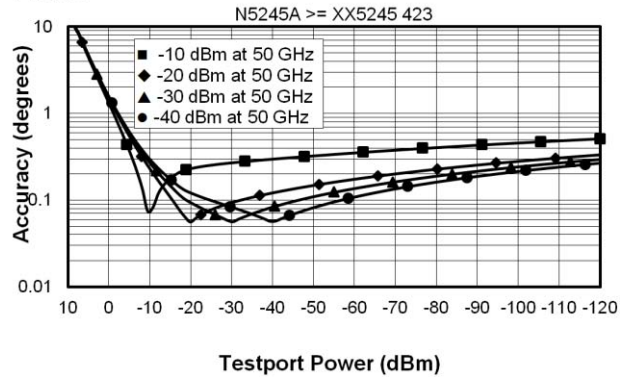


## Dynamic Accuracy, 50 GHz

Magnitude



Phase



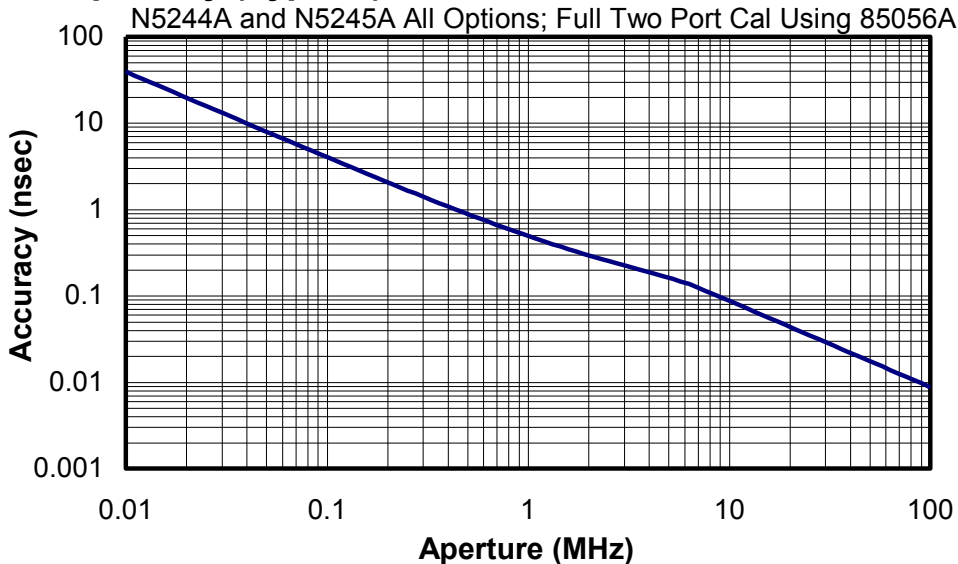
**Table 30. Test Port Input (Group Delay)<sup>1</sup>**

Description	Typical Performance
Aperture (selectable)	(frequency span)/(number of points -1)
Maximum Aperture	20% of frequency span
Range	0.5 x (1/minimum aperture)
Maximum Delay	Limited to measuring no more than 180° of phase change within the minimum aperture.)
Accuracy	See graph below. Char.

The following graph shows characteristic group delay accuracy with full 2-port calibration and a 10 Hz IF bandwidth. Insertion loss is assumed to be < 2 dB and electrical length to be ten meters.

For any  $S_{ij}$  Group Delay measurement,  $S_{ii} = 0$ ,  $S_{ij} = 1$ ,  $S_{ji} = 0$ ,  $S_{kl} = 0$  for all  $kl \neq ij$

### Group Delay (Typical)



In general, the following formula can be used to determine the accuracy, in seconds, of specific group delay measurement:

$$\pm \text{Phase Accuracy (deg)} / [360 \times \text{Aperture (Hz)}]$$

Depending on the aperture and device length, the phase accuracy used is either incremental phase accuracy or worst-case phase accuracy.

<sup>1</sup> Group delay is computed by measuring the phase change within a specified frequency step (determined by the frequency span and the number of points per sweep).

## General Information

- [Miscellaneous Information](#)
- [Front Panel](#)
- [Rear Panel](#)
- [Environment and Dimensions](#)

**Table 31. Miscellaneous Information**

Description	Supplemental Information
System IF Bandwidth Range	1 Hz to 15 MHz, nominal (7 MHz, 10 MHz, and 15 MHz IFBWs are available ONLY with FW A.09.42 and later, and with DSP version 5)
CPU	Intel 2.0 GHz Core i7. <b>Note:</b> Some instruments may have a different CPU. For the latest information on CPUs and associated hard drives, visit: <a href="http://na.tm.agilent.com/pna/hdnumbers.html">http://na.tm.agilent.com/pna/hdnumbers.html</a>
LXI	Class C

**Table 32. Front Panel Information, All Options**

Description	Typical Performance
<b>RF Connectors</b>	
Test Ports	2.4 mm (male), 50 ohm (nominal), 0.002 in. Center Pin Recession (characteristic)
Jumpers	2.4 mm (female) connectors with 2.4 mm (male) jumper cables
<b>USB 2.0 Ports - Master (4 ports)</b>	
Standard	Compatible with USB 2.0
Connector	USB Type-A female
<b>Display</b>	
Size	26.3 cm (10.4 in) diagonal color active matrix LCD; 1024 (horizontal) X 768 (vertical) resolution
Refresh Rate	Vertical 60 Hz; Horizontal 46.08 kHz
Pixels	Any of the following would cause a display to be considered faulty: <ul style="list-style-type: none"> <li>• A complete row or column consists of “stuck” or “dark” pixels.</li> <li>• More than six “stuck on” pixels (but not more than three green) or more than 0.002% of the total pixels are within the LCD specifications.</li> <li>• More than twelve “dark” pixels (but no more than seven of the same color) or more than 0.004% of the total pixels are within the LCD specifications.</li> <li>• Two or more consecutive “stuck on” pixels or three or more consecutive “dark” pixel (but no more than one set of two consecutive dark pixels)</li> <li>• “Stuck on” “dark” pixels are less than 6.5 mm apart (excluding consecutive pixels)</li> </ul>

**Table 32. (Continued) Front Panel Information, All Options**

<b>Description</b>	<b>Typical Performance</b>
<b>Display Range</b>	
Magnitude	$\pm 2500$ dB (at 500 dB/div), max
Phase	$\pm 2500^\circ$ (at 500 dB/div), max
Polar	10 pUnits, min 10,000 Units, max
<b>Display Resolution</b>	
Magnitude	0.001 dB/div, min
Phase	$0.01^\circ$ /div, min
<b>Marker Resolution</b>	
Magnitude	0.001 dB, min
Phase	$0.01^\circ$ , min
Polar	10 pUnit, min

**Table 33. Rear Panel Information, All Options**

<b>Description</b>	<b>Typical Performance</b>
<b>10 MHz Reference In</b>	
Connector	BNC, female
Input Frequency	10 MHz $\pm 10$ ppm
Input Level	-15 dBm to +20 dBm
Input Impedance	200 $\Omega$ , nom.
<b>10 MHz Reference Out</b>	
Connector	BNC, female
Output Frequency	10 MHz $\pm 1$ ppm
Signal Type	Sine Wave
Output Level	+10 dBm $\pm 4$ dB into 50 $\Omega$
Output Impedance	50 $\Omega$ , nominal
Harmonics	<-40 dBc, typical

**Table 33. (Continued) Rear Panel Information, All Options**

Description	Typical Performance			
<b>External IF Inputs</b>				
Function	Allows use of external IF signals from remote mixers, bypassing the PNA's first converters			
Connectors	SMA (female); A, B, C, D, R (4-port); A, B, R1, R2 (2-port)			
Frequency				
<b>Path</b>	<b>DSP Version</b>	<b>IF Bandwidth</b>	<b>RF Frequency</b>	<b>IF Frequency</b>
Normal IF path:	4	All	< 53 MHz	2.535211 MHz
		All	>= 53 MHz	7.605634 MHz
Narrowband IF path:	5	<= 600 kHz	< 53 MHz	2.479339 MHz
			>= 53 MHz	7.438017 MHz
		1 MHz	All	7.692 MHz
		1.5 MHz	All	7.368 MHz
		2 MHz	All	8.450 MHz
		3 MHz	All	8.163 MHz
		5 MHz	All	6.897 MHz
		7 MHz	All	10.53 MHz
		10 MHz	All	15.38 MHz
		15 MHz	All	22.22 MHz
Narrowband IF path:	4 or 5	All	All	10.70 MHz
Input Impedance	50 $\Omega$			
RF Damage Level	+23 dBm			
DC Damage Level	5.5 VDC			
0.1 dB Compression Point				
Normal IF path	-9.0 dBm at 7.438 MHz			
Narrowband IF path	-17 dBm at 10.70 MHz			
<b>Pulse Inputs (IF Gates)</b>				
Function	Internal receiver gates used for point-in-pulse and pulse-profile measurements			
Connectors	15-pin mini D-sub			
Input Impedance	1 K Ohm			
Source Modulators	20 ns minimum pulse width			
Receiver Gates	20 ns minimum pulse width			
DC Damage Level	5.5 VDC			
Drive Voltage	0 V (off), +3.3 V (on), nominal			

**Table 33. (Continued) Rear Panel Information, All Options**

Description	Typical Performance	
<b>RF Pulse Modulator Input (Source Modulator)</b>		
<b>On/Off Ratio</b>		
10 MHz to 3.2 GHz	-64 dB	
3.2 GHz to 50 GHz	-80 dB	
<b>Pulse Period</b>		
Minimum	20 ns	
Maximum	70 s	
<b>Pulse Outputs</b>		
Voltage (TTL)	High: 3.3V to 3.5V Low: <1V	
Impedance	50 Ohm	
<b>External Test Set Driver</b>		
Function	Used for driving remote mixers	
Connections	3.5 mm (female)	
RF Output Frequency Range	3.2 GHz to 19 GHz	
LO Output Frequency Range	1.76 GHz to 26.5 GHz	
<b>Rear Panel LO Power<sup>1</sup></b>	<b>Upper Limit, Typical (dBm)</b>	<b>Lower Limit, Typical (dBm)</b>
1.7 GHz to 6.78 GHz	5	-3
6.78 GHz to 15.5 GHz	0	-6
15.5 GHz to 26.5 GHz	4	-5
<b>Rear Panel RF Power</b>	<b>Upper Limit, Typical (dBm)</b>	<b>Lower Limit, Typical (dBm)</b>
3.2 GHz to 19 GHz	-3	-8

<sup>1</sup> LO output available in full analyzer's frequency range. The power is tested only from 3.2 GHz to 26.5 GHz.



**Table 33. (Continued) Rear Panel Information, All Options**

<b>Description</b>	<b>Typical Performance</b>
<b>VGA Video Output</b>	
Connector	15-pin mini D-Sub; Drives VGA compatible monitors
<b>Devices Supported</b>	<b>Resolutions</b>
Flat Panel (TFT)	1024 X 768, 800 X 600, 640 X 480
Flat Panel (DSTN)	800 X 600, 640 X 480
CRT Monitor	1280 X 1024, 1024 X 768, 800 X 600, 640 X 480
Simultaneous operation of the internal and external displays is allowed, but with 640 X 480 resolution only. If you change resolution, you can only view the external display (internal display will "white out").	
<b>Bias Tee Inputs</b>	
Connectors	BNC(f) for ports 1, 2, 3 and 4
Fuse	500 mA, bi-pin style
Maximum Bias Current	±200 mA with no degradation of RF specifications
Maximum Bias Voltage	±40 VDC
Trigger Inputs/Outputs	BNC(f), TTL/CMOS compatible
Test Set IO	25-pin D-Sub connector, available for external test set control.
Power IO	9-pin D-Sub, female; analog and digital IO
Handler IO	36-pin parallel I/O port; all input/output signals are default set to negative logic; can be reset to positive logic via GPIB command.
GPIB	Two ports - dedicated controller and dedicated talker/listener. 24-pin D-sub (Type D-24), female; compatible with IEEE-488.
Parallel Port (LPT1)	25-pin D-Sub miniature connector, female; provides connection to printers or any other parallel port peripherals
USB Ports	Four ports on front panel (all Host) and five ports (four Host and one Device) on rear panel. Type A configuration (eight Host) and Type B configuration (one Device), USB 2.0 compatible. The total current limit for all rear panel USB ports is 2.0 amps. The total current limit for all front panel USB is 0.9 amps.
LAN	10/100BaseT Ethernet, 8-pin configuration; auto selects between the two data rates
<b>Line Power</b>	
Frequency, Voltage	50/60/400 Hz for 100 to 120 VAC 50/60 Hz for 220 to 240 VAC
	Power supply is auto switching
Max	450 watts

### Table 34. Analyzer Dimensions and Weight

All models are shipped with bottom feet, handles and front and rear hardware.

See detailed PNA dimension drawings at: <http://na.tm.agilent.com/pna/PNADimensions.pdf>

<b>Cabinet Dimensions</b>	<b>Metric (mm)</b>	<b>Imperial (inches)</b>
<b>Height</b>		
Without bottom feet:EIA RU <sup>1</sup> = 6	266.1	10.5
With bottom feet	279.1	11.0
<b>Width</b>		
Without handles or rack-mount flanges	425.6	16.8
With handles, without rack-mount flanges	458.7	18.1
With handles and rack-mount flanges	482.9	19.0
<b>Depth</b>		
Without front and rear panel hardware	582.3	22.9
With front and rear panel hardware, handles	649.6	25.6
<b>Weight (nominal)</b>		
	<b>Net</b>	<b>Shipping</b>
2-port models (Option 224 with 029)	46.3 kg (102 lb)	62.1 kg (137 lb)
4-port models (Option 423 with 029)	49.0 kg (108 lb)	65.3 kg (144 lb)

<sup>1</sup> Electronics Industry Association rack units. 1 RU = 1.75 in.

### Regulatory and Environmental Information

For Regulatory and Environmental information, refer to the PNA Series Installation and Quick Start Guide, located online at <http://cp.literature.agilent.com/litweb/pdf/E8356-90001.pdf>.

## Measurement Throughput Summary

- [Typical Cycle Time for Measurement Completion](#)
- [Cycle Time vs. IF Bandwidth](#)
- [Cycle Time vs. Number of Points](#)
- [Data Transfer Time](#)

Cycle time Includes sweep time, retrace time and band-crossing time. Analyzer display turned off with DISPLAY:ENABLE OFF. Add 21 ms for display on. Data for one trace (S<sub>11</sub>) measurement.

**Table 35a. Cycle Time (ms) for Measurement Completion, All Models, All Options - Typical**

Sweep Range	IF Bandwidth		Number of Points				
			201	401	1601	16001	32001
9 GHz to 10 GHz	600 kHz	Uncorrected	5.5	5.5	9.4	59.4	116
		2-Port cal	17.2	18.0	16.6	132	250
	10 kHz	Uncorrected	28.1	53.1	203	1995	3988
		2-Port cal	65.6	116	414	4003	7991
	1 kHz	Uncorrected	227	445	1744	17028	33828
		2-Port cal	461	898	3150	30669	67680
10 GHz to 20 GHz	600 kHz	Uncorrected	17.2	18.8	23.4	68.8	120
		2-Port cal	43.8	46.9	56.3	155	259
	10 kHz	Uncorrected	67.2	127	259	2003	3995
		2-Port cal	144	261	523	4016	8003
	1 kHz	Uncorrected	233	456	1781	17375	34516
		2-Port cal	475	922	3570	34758	69055

**Table 35b. N5244A Cycle Time (ms) for Full-Span Measurement Completion - Typical**

<b>10 MHz to 43.5 GHz</b>		<b>Number of Points</b>				
<b>IF Bandwidth</b>		<b>201</b>	<b>401</b>	<b>1601</b>	<b>16001</b>	<b>32001</b>
600 kHz	Uncorrected	48.4	59.4	78.1	156	206
	2-Port cal	105	127	164	317	428
10 kHz	Uncorrected	84.4	147	505	2172	4188
	2-Port cal	175	302	1016	4350	8384
1 kHz	Uncorrected	250	477	1822	17617	34984
	2-Port cal	505	959	3647	35250	69992

**Table 35c. N5245A Cycle Time (ms) for Full-Span Measurement Completion - Typical**

<b>10 MHz to 50 GHz</b>		<b>Number of Points</b>				
<b>IF Bandwidth</b>		<b>201</b>	<b>401</b>	<b>1601</b>	<b>16001</b>	<b>32001</b>
600 kHz	Uncorrected	55.5	67.2	85.9	166	223
	2-Port cal	116	141	175	334	443
10 kHz	Uncorrected	87.5	151	512	2182	4203
	2-Port cal	180	307	1027	4364	8422
1 kHz	Uncorrected	252	480	1825	17648	35031
	2-Port cal	509	966	3656	35305	70086

**Table 36. Cycle Time vs. IF Bandwidth - Typical**

Applies to the Preset condition (201 points, correction off) except for the following changes:

- CF = 10 GHz
- Span = 100 MHz
- Display off (add 21 ms for display on)

Cycle time includes sweep and retrace time.

<b>Description</b>		<b>N5244A/45A</b>	
<b>IF Bandwidth (Hz)</b>	<b>Cycle Time (ms)</b>	<b>Trace Noise Magnitude (dB rms)</b>	
600,000	5.5	0.005	
100,000	5.5	0.0024	
30,000	8.6	0.0017	
10,000	28.9	0.0014	
3,000	70.3	0.001	
1,000	223	0.0008	
300	642	0.0006	
100	1823	0.0005	
30	5977	0.0005	
10	17836	0.0005	
3	59289	0.0004	

**Table 37. Cycle Time (ms) vs. Number of Points - Typical**

Applies to the Preset condition (correction off) except for the following changes:

- CF = 10 GHz
- Span = 100 MHz
- Display off (add 21 ms for display on)

Cycle time includes sweep and retrace time.

Description	IF Bandwidth (Hz)			
Number of Points	1,000	10,000	30,000	600,000
3	6.3	4.7	4.7	4.7
11	15.6	5.5	4.7	4.7
51	59.4	10.2	4.7	4.7
101	113	15.6	6.3	4.7
201	222	28.1	8.6	4.7
401	436	53.1	14.1	5.5
801	859	103	23.4	6.3
1,601	1706	203	43.8	9.4
6,401	6719	800	166	26.6
16,001	16656	1995	408	60.2
32,001	33086	3988	812	116

**Table 38. Data Transfer Time<sup>1</sup> (ms) - Typical**

Description	Number of Points				
	201	401	1601	16,001	32,001
<b>SCPI over GPIB</b> (Program executed on external PC <sup>2</sup> )					
32-bit floating point	4.6	9.3	38	352	720
64-bit floating point	9.4	18.8	73.4	730	1455
ASCII	36.7	72.5	288	2882	5762
<b>SCPI over SICL/LAN or TCP/IP Socket<sup>3</sup></b> (Program executed in the analyzer)					
32-bit floating point	<1	<1	<1	1.2	2.4
64-bit floating point	<1	<1	<1	2.3	4.6
ASCII	2.1	4	15	148	295
<b>COM<sup>1</sup></b> (Program executed in the analyzer)					
32-bit floating point	<1	<1	<1	<1	<1
Variant type	<1	<1	1.4	12.4	25.5
<b>DCOM over LAN<sup>3</sup></b> (Program executed on external PC)					
32-bit floating point	<1	<1	<1	2.3	4.4
Variant type	<1	1.6	5.3	52	105.5

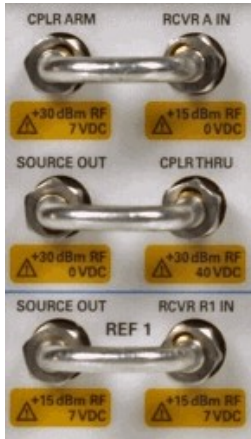
<sup>1</sup> Measured with the analyzer display off. Values will increase slightly if the analyzer display is on.

<sup>2</sup> Measured when using the SCPI command DISPlay: VISible OFF.

<sup>3</sup> Values are for real and imaginary pairs, with the analyzer display off, using Gigabit Ethernet.

**Note:** Specifications for Recall & Sweep Speed are not provided for the N522xA analyzers.

## Front-Panel Jumpers



**Note:** All PNA-X options have the following front-panel jumpers for each port.

- [Measurement Receiver Inputs](#)
- [Reference Receiver Inputs and Reference Source Outputs](#)
- [Source Outputs](#)
- [Coupler Inputs](#)
- [Damage Level](#)

**Table 39. Measurement Receiver Inputs (dBm) - Typical**

**(RCVR A, B, C, D IN) @ 0.1dB Typical Compression**

Description	All Options
10 MHz to 1 GHz	-2
1 GHz to 2 GHz	-1
2 GHz to 10 GHz	0
10 GHz to 16 GHz	-3
16 GHz to 26.5 GHz	-2
26.5 GHz to 43.5 GHz	-1
43.5 GHz to 50 GHz	0



**Table 40a. Reference Receiver Inputs and Reference Source Outputs (dBm) - Typical**  
**(RCVR R1 IN, REF 1 SOURCE OUT) @ Max Specified Output Power**

Description	Option 200, 400		Option 219, 419		Option 224, 423	
	Filtered Mode <sup>1</sup>	Hi Power Mode <sup>1</sup>	Filtered Mode <sup>1</sup>	Hi Power Mode <sup>1</sup>	Filtered Mode <sup>1</sup>	Hi Power Mode <sup>1</sup>
10 MHz to 50 MHz	-33	-25	-32	-27	-32	-25
50 MHz to 500 MHz	-21	-16	-19	-14	-19	-14
500 MHz to 1 GHz	-9	-4	-7	-2	-7	-2
1 GHz to 2 GHz	-9	-4	-7	-3	-7	-2
2 GHz to 3.2 GHz	-8	-6	-6	-4	-7	-5
3.2 GHz to 10 GHz	-3	-3	0	0	-3	-3
10 GHz to 16 GHz	-3	-3	-1	-1	-3	-3
16 GHz to 26.5 GHz	-3	-3	-1	-1	-4	-4
26.5 GHz to 30 GHz	-3	-3	0	0	-3	-3
30 GHz to 32 GHz	-4	-4	-2	-2	-5	-5
32 GHz to 35 GHz	-2	-2	0	0	-2	-2
35 GHz to 43.5 GHz	-3	-3	-1	-1	-5	-5
43.5 GHz to 47 GHz	-6	-6	-5	-5	-23	-23
47 GHz to 50 GHz	-19	-19	-17	-17	-22	-22

<sup>1</sup> In Filtered Mode, the signal path goes through filters to minimize harmonics below 3.2 GHz. In Hi Power Mode, the signal bypasses the filters to maximize output power.

**Table 40b. Reference Receiver Inputs and Reference Source Outputs (dBm) - Typical**  
**(RCVR R2, R3, R4 IN, REF 2, 3, 4 SOURCE OUT) @ Max Specified Output Power**

Description	Option 400		Options 200, 400	Option 419		Options 219, 419
	RCVR R3 IN, REF 3 SOURCE OUT	RCVR R3 IN, REF 3 SOURCE OUT	RCVR R2, R4 IN, REF 2, 4 SOURCE OUT	RCVR R3 IN, REF 3 SOURCE OUT	RCVR R3 IN, REF 3 SOURCE OUT	RCVR R2, R4 IN, REF 2, 4 SOURCE OUT
	Filtered Mode <sup>1</sup>	Hi Power Mode <sup>1</sup>		Filtered Mode <sup>1</sup>	Hi Power Mode <sup>1</sup>	
10 MHz to 50 MHz	-31	-23	-27	-31	-26	-25
50 MHz to 500 MHz	-19	-14	-14	-18	-13	-14
500 MHz to 1 GHz	-7	-2	-2	-6	-1	-2
1 GHz to 2 GHz	-7	-2	-2	-6	-2	-2
2 GHz to 3.2 GHz	-7	-5	-2	-4	-2	-2
3.2 GHz to 10 GHz	-1	-1	-1	1	1	-1
10 GHz to 16 GHz	-1	-1	-1	0	0	-2
16 GHz to 26.5 GHz	-1	-1	-1	1	1	-2
26.5 GHz to 30 GHz	0	0	-1	2	2	-3
30 GHz to 32 GHz	-1	-1	-2	0	0	-5
32 GHz to 35 GHz	0	0	-1	2	2	-3
35 GHz to 43.5 GHz	-2	-2	-2	0	0	-5
43.5 GHz to 47 GHz	-5	-5	-5	-4	-4	-9
47 GHz to 50 GHz	-17	-17	-17	-16	-16	-21

<sup>1</sup> In Filtered Mode, the signal path goes through filters to minimize harmonics below 3.2 GHz. In Hi Power Mode, the signal bypasses the filters to maximize output power.

**Table 40c. Reference Receiver Inputs and Reference Source Outputs (dBm) - Typical**  
**(RCVR R2, R3, R4 IN, REF 2, 3, 4 SOURCE OUT) @ Max Specified Output Power**

Description	Options 423		Options 224, 423
	RCVR R3 IN, REF 3 SOURCE OUT	RCVR R3 IN, REF 3 SOURCE OUT	RCVR R2, R4 IN, REF 2, 4 SOURCE OUT
	Filtered Mode <sup>1</sup>	Hi Power Mode <sup>1</sup>	
10 MHz to 50 MHz	-31	-24	-29
50 MHz to 500 MHz	-18	-13	-16
500 MHz to 2 GHz	-6	-1	-4
2 GHz to 3.2 GHz	-5	-3	-4
3.2 GHz to 10 GHz	0	0	0
10 GHz to 26.5 GHz	-2	-2	-2
26.5 GHz to 30 GHz	-1	-1	-2
30 GHz to 32 GHz	-3	-3	-4
32 GHz to 35 GHz	0	0	-2
35 GHz to 43.5 GHz	-3	-3	-4
43.5 GHz to 47 GHz	-22	-22	-8
47 GHz to 50 GHz	-21	-21	-21

<sup>1</sup> In Filtered Mode, the signal path goes through filters to minimize harmonics below 3.2 GHz. In Hi Power Mode, the signal bypasses the filters to maximize output power.

**Table 41a. Source Outputs (dBm) - Typical****(PORT 1, 2, 3, 4 SOURCE OUT) @ Max Specified Output Power**

Description	Options 200, 400			Options 219, 419		
	PORT 1, 3 SOURCE OUT		PORT 2, 4 SOURCE OUT	PORT 1, 3 SOURCE OUT		PORT 2, 4 SOURCE OUT
	Filtered Mode <sup>1</sup>	Hi Power Mode <sup>1</sup>		Filtered Mode <sup>1</sup>	Hi Power Mode <sup>1</sup>	
10 MHz to 50 MHz	4	12	12	5	10	13
50 MHz to 1 GHz	8	13	13	9	14	14
1 GHz to 2 GHz	9	14	14	9	13	14
2 GHz to 3.2 GHz	9	11	14	9	11	14
3.2 GHz to 10 GHz	14	14	14	14	14	14
10 GHz to 16 GHz	14	14	14	13	13	13
16 GHz to 26.5 GHz	14	15	15	13	13	13
26.5 GHz to 30 GHz	14	14	14	12	12	12
30 GHz to 32 GHz	13	13	13	10	10	10
32 GHz to 35 GHz	14	14	14	12	12	12
35 GHz to 43.5 GHz	11	11	11	8	8	8
43.5 GHz to 47 GHz	8	8	8	4	4	4
47 GHz to 50 GHz	-5	-5	-5	-8	-8	-8

<sup>1</sup> In Filtered Mode, the signal path goes through filters to minimize harmonics below 3.2 GHz. In Hi Power Mode, the signal bypasses the filters to maximize output power.

**Table 41b. Source Outputs (dBm) - Typical****(PORT 1, 2, 3, 4 SOURCE OUT) @ Max Specified Output Power**

Description	Options 224, 423, 029			
	PORT 1, 3 SOURCE OUT		PORT 2, 4 SOURCE OUT	
	Filtered Mode <sup>1</sup>	Hi Power Mode <sup>1</sup>		
10 MHz to 50 MHz	5	12		11
50 MHz to 2 GHz	9	14		14
2 GHz to 3.2 GHz	9	11		14
3.2 GHz to 10 GHz	14	14		14
10 GHz to 26.5 GHz	13	13		13
26.5 GHz to 30 GHz	12	12		12
30 GHz to 32 GHz	10	10		10
32 GHz to 35 GHz	12	12		12
35 GHz to 43.5 GHz	8	8		8
43.5 GHz to 47 GHz	3	3		3
47 GHz to 50 GHz	-9	-9		-10

<sup>1</sup> In Filtered Mode, the signal path goes through filters to minimize harmonics below 3.2 GHz. In Hi Power Mode, the signal bypasses the filters to maximize output power.

**Table 42. Coupler Inputs (dB) - Typical****(PORT 1, 2, 3, 4 CPLR THRU) Insertion Loss of Coupler Thru**

Description	Options 200, 400	Options 219, 419, 224, 423	Option 029 <sup>1</sup>
	All Ports	All Ports	Ports 1, 2
10 MHz to 500 MHz	0.25	1	1.5
500 MHz-to 2 GHz	0.5	1	1.5
2 GHz to 10 GHz	1	1	1.5
10 GHz to 16 GHz	1	2	2.5
16 GHz to 26.5 GHz	1.5	2.5	3.0
26.5 GHz to 35 GHz	2	3	3.7
35 GHz to 43.5 GHz	2.5	4	4.7
43.5 GHz to 47 GHz	2.5	5	5.7
47 GHz to 50 GHz	3	6	7

<sup>1</sup> Option 029 affects only port 1 and 2 coupler thru insertion loss. Refer to Options 219, 419, 224, 423 for the coupler thru insertion loss on port 3 or port 4. Port 1 impedance tuner switch is in bypass position and port 2 noise receiver switch is in normal position.

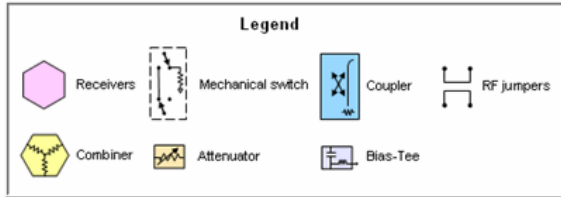
**Table 43. Damage Level - Typical**

Description	RF (dBm)	DC (v)
RCVR A, B, C, D IN	15	7
RCVR R1, R2, R3, R4 IN	15	7
REF 1 SOURCE OUT	15	7
REF 2, 3, 4 SOURCE OUT	30	7
PORT 1, 2, 3, 4 SOURCE OUT	27	5
PORT 1CPLR THRU	10	40
PORT 2, 3, 4 CPLR THRU	27	40
PORT 1, 2, 3, 4 CPLR ARM	30	7

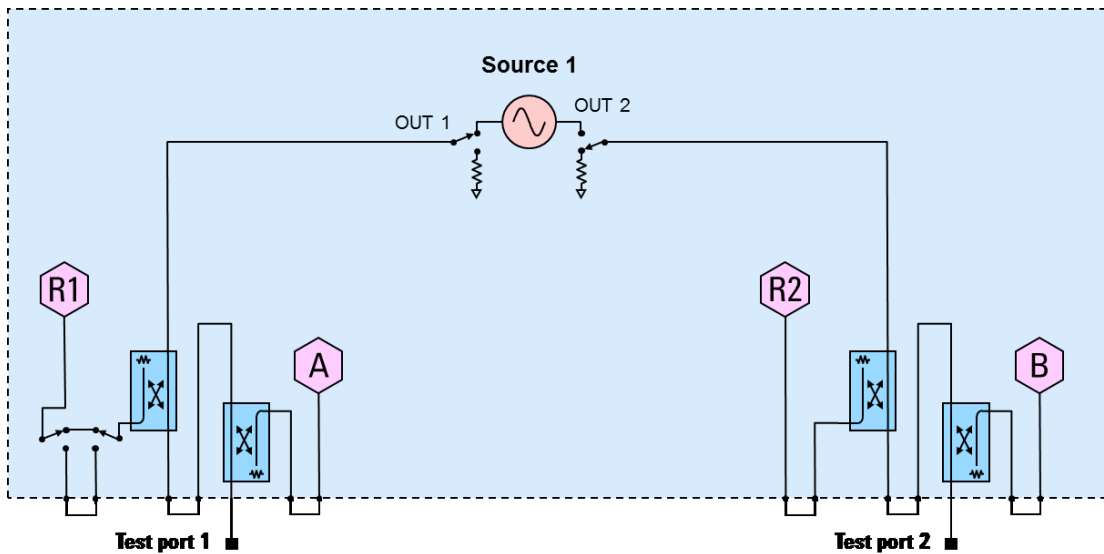
## Test Set Block Diagrams

NOTE: For best readability, use a color printer for printing the following graphics.

### Legend

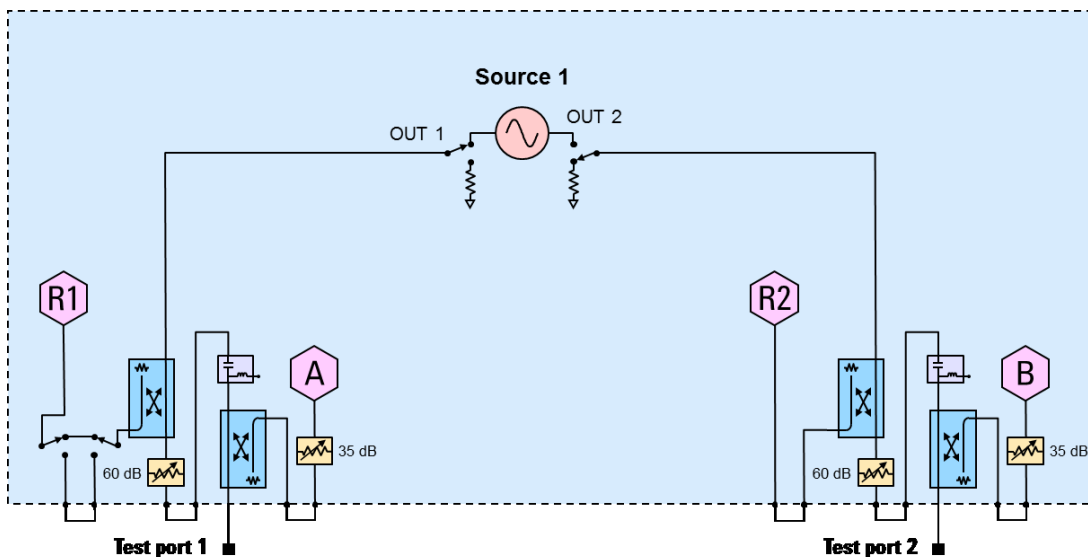


**Figure 1. 2-Port N5244A and N5245A Base Unit Option 200**



**Figure 2. 2-Port N5244A and N5245A Option 219**

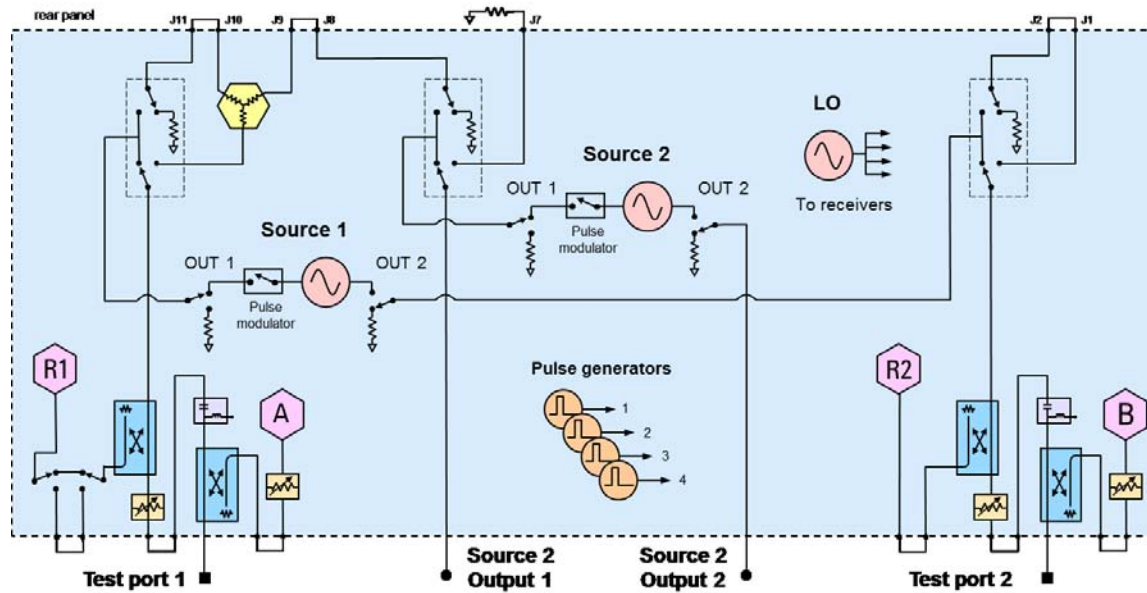
Adds extended power range: source and receiver attenuators, and bias-tees



**Figure 3. 2-Port N5244A and N5245A Option 224**

Adds internal second source, combiner, and mechanical switches

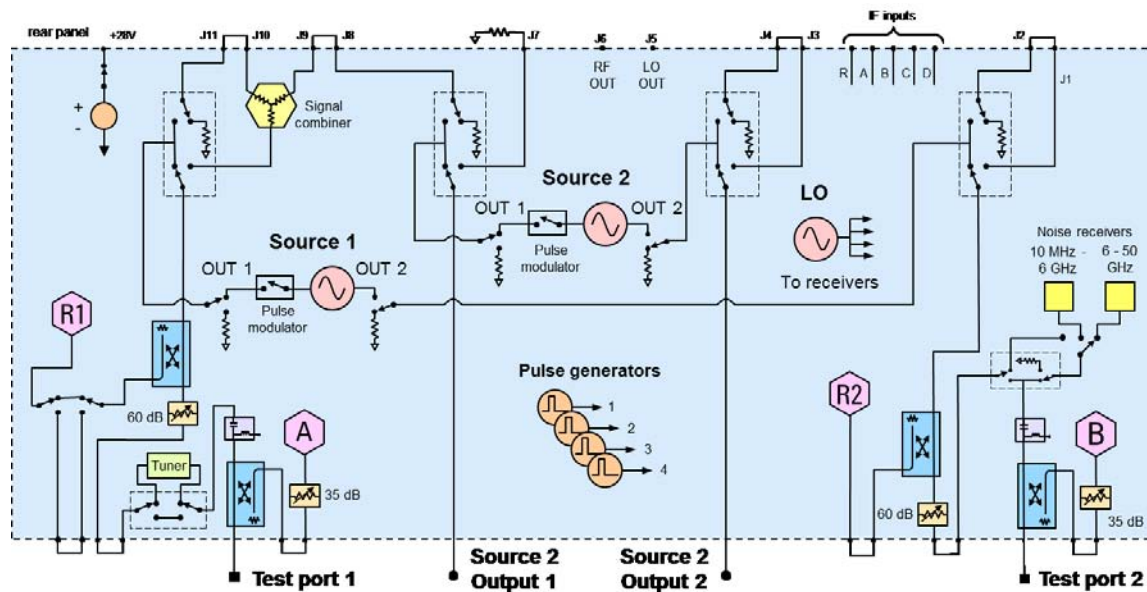
Also shown, Option 025 adds 4 pulse generators. Option 021 and 022 adds pulse modulators.



**Figure 4. 2-Port N5244A and N5245A Option 224 with 029**

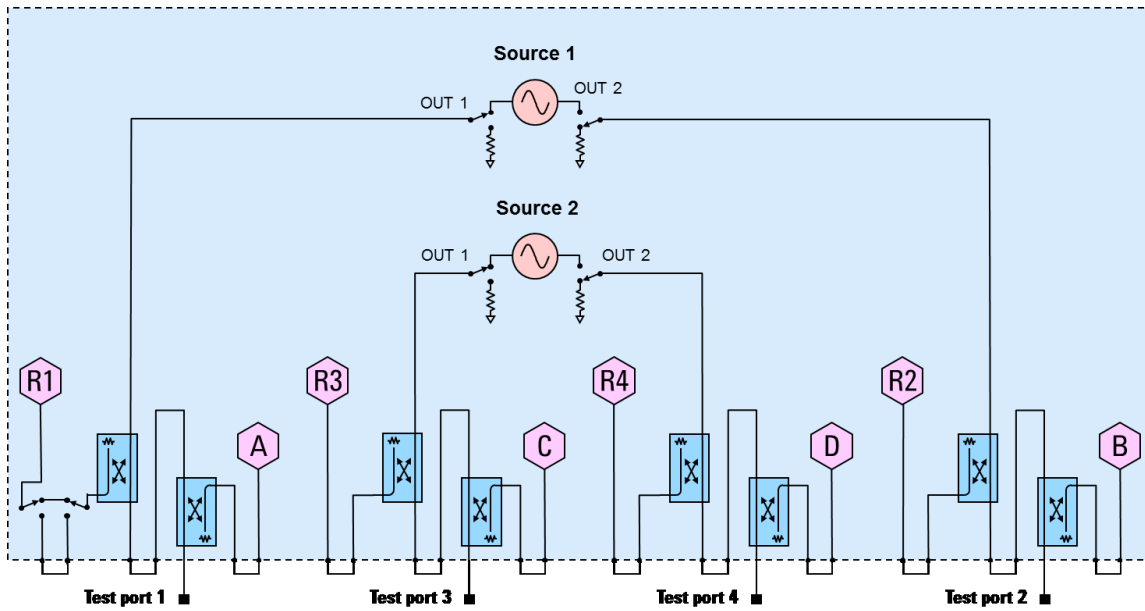
Adds internal second source, combiner, mechanical switches and impedance tuner/noise receiver.

Also shown, Option 025 adds 4 pulse generators. Option 021 and 022 adds pulse modulators.



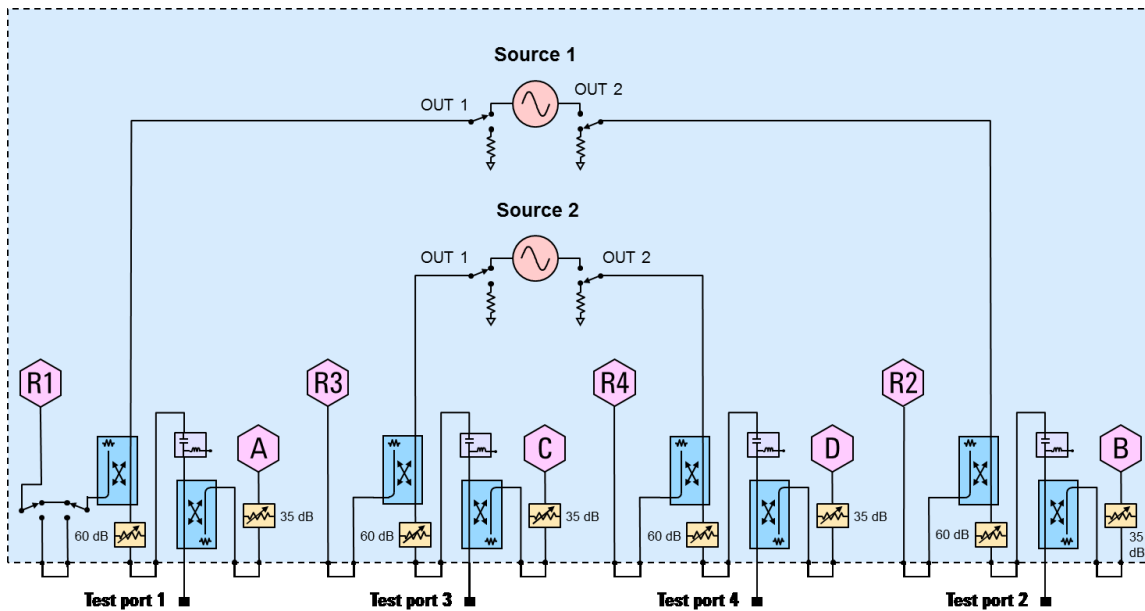


**Figure 5. 4-Port N5244A and N5245A Base Unit - Option 400**



**Figure 6. 4-Port N5244A and N5245A Option 419**

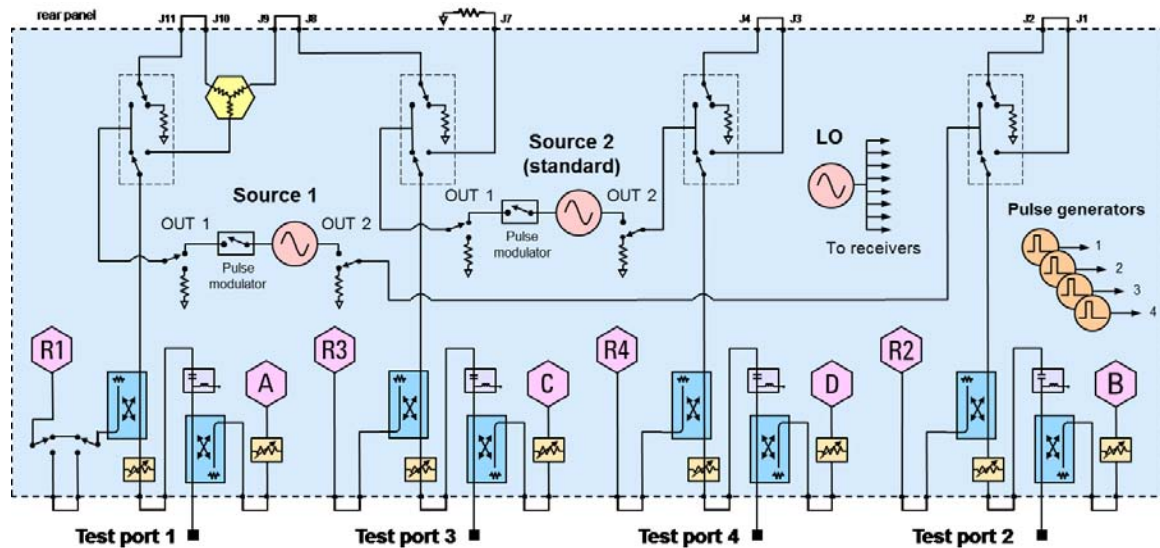
Adds extended power range: source and receiver attenuators, and bias-tees.



**Figure 7. 4-Port N5244A and N5245A Option 423**

Adds internal combiner and mechanical switches.

Also shown, Option 025 adds 4 pulse generators. Option 021 and 022 adds pulse modulators.



**Figure 8. 4-Port N5244A and N5245A Option 423 with 029**

Adds internal combiner, mechanical switches and impedance tuner/noise receiver.

Also shown, Option 025 adds 4 pulse generators. Option 021 and 022 adds pulse modulators.

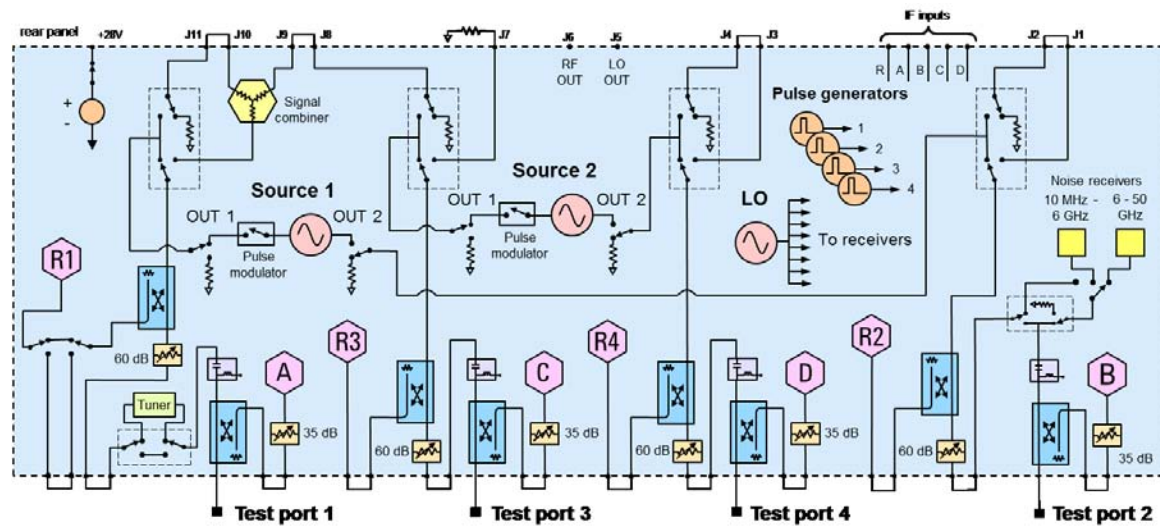
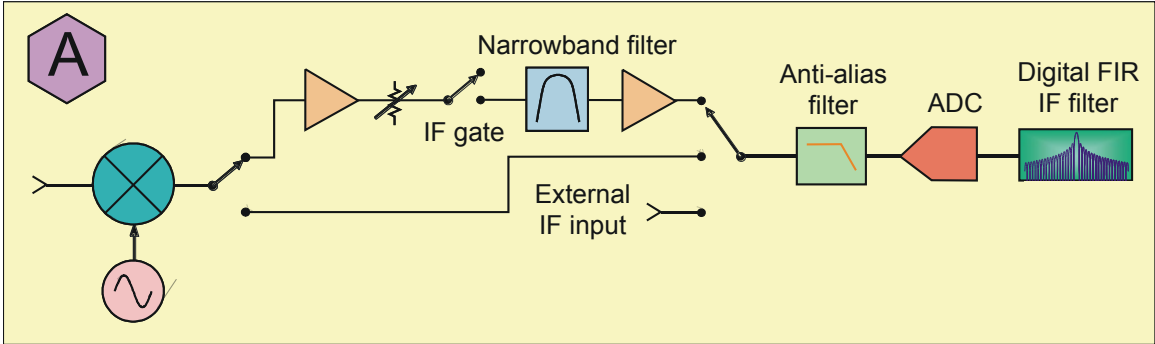


Figure 9. Receiver Block Diagram





## Agilent Email Updates

### [www.agilent.com/find/emailupdates](http://www.agilent.com/find/emailupdates)

Get the latest information on the products and applications you select.



### [www.axiestandard.org](http://www.axiestandard.org)

AdvancedTCA® Extensions for Instrumentation and Test (AXIe) is an open standard that extends the AdvancedTCA for general purpose and semiconductor test. Agilent is a founding member of the AXIe consortium.



### [www.lxistandard.org](http://www.lxistandard.org)

LAN eXtensions for Instruments puts the power of Ethernet and the Web inside your test systems. Agilent is a founding member of the LXI consortium.



### [www.pxisa.org](http://www.pxisa.org)

PCI eXtensions for Instrumentation (PXI) modular instrumentation delivers a rugged, PC-based high-performance measurement and automation system.

## Agilent Channel Partners

### [www.agilent.com/find/channelpartners](http://www.agilent.com/find/channelpartners)

Get the best of both worlds: Agilent's measurement expertise and product breadth, combined with channel partner convenience.



Agilent Advantage Services is committed to your success throughout your equipment's lifetime. To keep you competitive, we continually invest in tools and processes that speed up calibration and repair and reduce your cost of ownership. You can also use Infoline Web Services to manage equipment and services more effectively. By sharing our measurement and service expertise, we help you create the products that change our world.

[www.agilent.com/find/advantageservices](http://www.agilent.com/find/advantageservices)



## [www.agilent.com](http://www.agilent.com)

## [www.agilent.com/find/pnax](http://www.agilent.com/find/pnax)

For more information on Agilent Technologies' products, applications or services, please contact your local Agilent office. The complete list is available at:

## [www.agilent.com/find/contactus](http://www.agilent.com/find/contactus)

### Americas

Canada	(877) 894-4414
Brazil	(11) 4197 3500
Mexico	01800 5064 800
United States	(800) 829-4444

### Asia Pacific

Australia	1 800 629 485
China	800 810 0189
Hong Kong	800 938 693
India	1 800 112 929
Japan	0120 (421) 345
Korea	080 769 0800
Malaysia	1 800 888 848
Singapore	1 800 375 8100
Taiwan	0800 047 866
Other AP Countries	(65) 375 8100

### Europe & Middle East

Belgium	32 (0) 2 404 93 40
Denmark	45 70 13 15 15
Finland	358 (0) 10 855 2100
France	0825 010 700* *0.125 €/minute
Germany	49 (0) 7031 464 6333
Ireland	1890 924 204
Israel	972-3-9288-504/544
Italy	39 02 92 60 8 484
Netherlands	31 (0) 20 547 2111
Spain	34 (91) 631 3300
Sweden	0200-88 22 55
United Kingdom	44 (0) 118 9276201

For other unlisted countries:

## [www.agilent.com/find/contactus](http://www.agilent.com/find/contactus)

Product specifications and descriptions in this document subject to change without notice.

© Agilent Technologies, Inc.

Published in USA, Feb 25, 2013

Supersedes: Dec. 13, 2012

N5245-90008



Agilent Technologies