

FLUKE®

**The 5700A/5720A Series II
High Performance
Multifunction Calibrators
Extended Specifications**



5720A Calibrator



General Specifications

Warm-Up Time	Twice the time since last warmed up, to a maximum of 30 minutes.
System Installation	Rear output configuration and rack- mount kit available.
Standard Interfaces	IEEE-488, RS-232, 5725A, 5205A or 5215A, 5220A, phase lock in (BNC), phase reference out (BNC).
Temperature Performance	
Operating.....	0 °C to 50 °C
Calibration.....	15 °C to 35 °C
Storage.....	-40 °C to 75 °C
Relative Humidity	
Operating.....	<80 % to 30 °C, <70 % to 40 °C, <40 % to 50 °C
Storage.....	<95 %, non-condensing. A power stabilization period of four days may be required after extended storage at high temperature and humidity.
Safety	Designed to comply with UL3111; EN61010; CSA C22.2 No. 1010; ANSI/ISA S82.01-1994
Guard Isolation	20 V
EMI/RFI	Designed to comply with FCC Rules Part 15, Subpart B, Class B; EN50081-1, EN50082-1
ElectroStatic Discharge	This instrument meets criteria C for ESD requirements per EN61326
Line Power	
Line Frequency.....	47 to 63 Hz; ±10 % 100 V, 110 V, 115 V, 120 V, 200 V, 220 V, 230 V, 240 V
Maximum Power	
5700A/5720A.....	300 VA
5725A.....	750 VA
Weight	
5700A/5720A.....	27kg (62 lbs)
5725A.....	32kg (70 lbs)
Size	
5700A/5720A	
Height.....	17.8 cm (7 in), standard rack increment, plus 1.5 cm (0.6 in) for feet
Width.....	43.2 cm (17 in), standard rack width
Depth.....	63.0 cm (24.8 in), overall; 57.8 cm (22.7 in), rack depth
5725A	
Height.....	13.3 cm, (5.25 in)
Width and Depth.....	Same as 5700A/5720A. Both units project 5.1 cm, (2 in) from rack front.

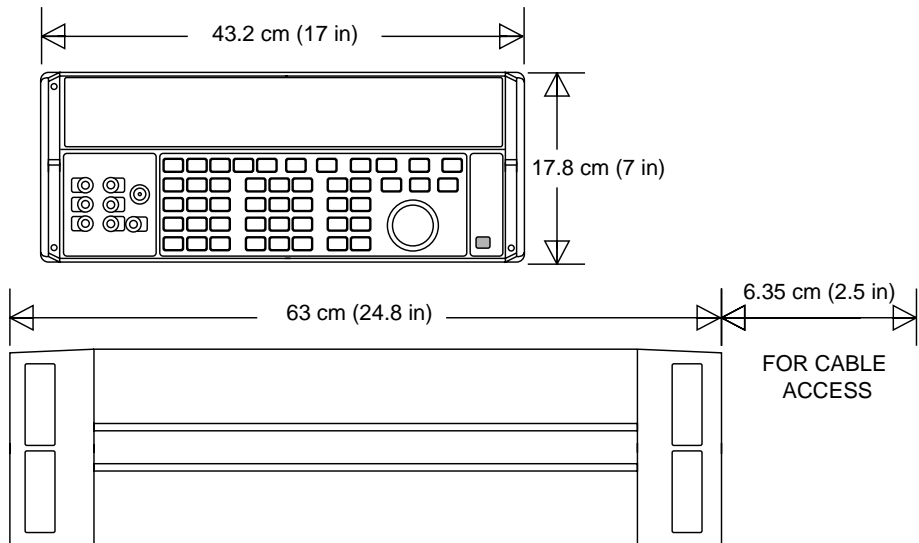

Electrical Specifications

Note

Fluke guarantees performance verification using specifications stated to 99% confidence level.

DC Voltage Specifications

5720A Series II DC Voltage Specifications

Range	Resolution	Absolute Uncertainty ± 5 °C from calibration temperature ⁽¹⁾				Relative Uncertainty ± 1 °C	
		24 Hours	90 Days	180 Days	1 Year	24 Hours	90 Days
± (ppm output + μV)							
99 % Confidence Level							
220 mV	10 nV	5 + 0.5	7 + 0.5	8 + 0.5	9 + 0.5	2 + 0.4	2.5 + 0.4
2.2 V	100 nV	3.5 + 0.8	4 + 0.8	4.5 + 0.8	6 + 0.8	2 + 0.8	2.5 + 0.8
11 V	1 μV	2.5 + 3	3 + 3	3.5 + 3	4 + 3	1 + 3	1.5 + 3
22 V	1 μV	2.5 + 5	3 + 5	3.5 + 5	4 + 5	1 + 5	1.5 + 5
220 V	10 μV	3.5 + 50	4 + 50	5 + 50	6 + 50	2 + 50	2.5 + 50
1100 V	100 μV	5 + 500	6 + 500	7 + 500	8 + 500	2.5 + 400	3 + 400
95 % Confidence Level							
220 mV	10 nV	4 + 0.4	6 + 0.4	6.5 + 0.4	7.5 + 0.4	1.6 + 0.4	2 + 0.4
2.2 V	100 nV	3 + 0.7	3.5 + 0.7	4 + 0.7	5 + 0.7	1.6 + 0.7	2 + 0.7
11 V	1 μV	2 + 2.5	2.5 + 2.5	3 + 2.5	3.5 + 2.5	0.8 + 2.5	1.2 + 2.5
22 V	1 μV	2 + 4	2.5 + 4	3 + 4	3.5 + 4	0.8 + 4	1.2 + 4
220 V	10 μV	3 + 40	3.5 + 40	4 + 40	5 + 40	1.6 + 40	2 + 40
1100 V	100 μV	4 + 400	4.5 + 400	6 + 400	6.5 + 400	2 + 400	2.4 + 400
Notes:							
DC Zeros calibration required every 30 days.							
1. For fields strengths >1 V/m but ≤3 V/m, add 0.01 % of range.							

5700A Series II DC Voltage Specifications

Range	Resolution	Absolute Uncertainty ± 5 °C from calibration temperature ⁽¹⁾				Relative Uncertainty ± 1 °C	
		24 Hours	90 Days	180 Days	1 Year	24 Hours	90 Days
		± (ppm output + μV)					
99 % Confidence Level							
220 mV	10 nV	6.5 + .75	7 + .75	8 + .75	9 + .8	2.5 + .5	4 + .5
2.2 V	100 nV	3.5 + 1.2	6 + 1.2	7 + 1.2	8 + 1.2	2.5 + 1.2	4 + 1.2
11 V	1 μV	3.5 + 3	5 + 4	7 + 4	8 + 4	1.5 + 3	3.5 + 4
22 V	1 μV	3.5 + 6	5 + 8	7 + 8	8 + 8	1.5 + 6	3.5 + 8
220 V	10 μV	5 + 100	6 + 100	8 + 100	9 + 100	2.5 + 100	4 + 100
1100 V	100 μV	7 + 600	8 + 600	10 + 600	11 + 600	3 + 600	4.5 + 600
95 % Confidence Level							
220 mV	10 nV	5.5 + 0.6	6 + 0.6	7 + 0.6	8 + 0.6	2 + 0.4	3.5 + 0.4
2.2 V	100 nV	3.5 + 1	5 + 1	6 + 1	7 + 1	2 + 1	3.5 + 1
11 V	1 mV	3 + 3.5	4 + 3.5	6 + 3.5	7 + 3.5	1.2 + 3	3 + 3.5
22 V	1 mV	3 + 6.5	4 + 6.5	6 + 6.5	7 + 6.5	1.2 + 6	3 + 7
220 V	10 mV	4 + 80	5 + 80	7 + 80	8 + 80	2 + 80	3.5 + 80
1100 V	100 mV	6 + 500	7 + 500	8 + 500	9 + 500	2.4 + 500	4 + 500
Notes:							
DC Zeros calibration required every 30 days.							
1. For fields strengths >1 V/m but ≤ 3 V/m, add 0.01 % of range.							

DC Voltage Secondary Performance Specifications and Operating Characteristics

Range	Stability ^[1] ± 1 °C 24 Hours	Temperature Coefficient Adder ^[2]		Linearity ± 1 °C	Noise	
		10 - 40 °C	0 - 10 °C and 40 - 50 °C		Bandwidth 0.1-10 Hz pk-pk	Bandwidth 10 Hz-10 kHz RMS
	± (ppm output + μV)	± (ppm output + μV) / °C		± (ppm output + μV)	μV	
220 mV	0.3 + 0.3	0.4 + 0.1	1.5 + 0.5	1 + 0.2	0.15 + 0.1	5
2.2 V	0.3 + 1	0.3 + 0.1	1.5 + 2	1 + 0.6	0.15 + 0.4	15
11 V	0.3 + 2.5	0.15 + 0.2	1 + 1.5	0.3 + 2	0.15 + 2	50
22 V	0.4 + 5	0.2 + 0.4	1.5 + 3	0.3 + 4	0.15 + 4	50
220 V	0.5 + 40	0.3 + 5	1.5 + 40	1 + 40	0.15 + 60	150
1100 V	0.5 + 200	0.5 + 10	3 + 200	1 + 200	0.15 + 300	500

Notes:

- Stability specifications are included in the Absolute Uncertainty values in the primary specification tables.
- Temperature coefficient is an adder to uncertainty specifications that does *not* apply unless operating more than ±5 °C from calibration temperature.

- Minimum Output**0 V for all ranges, except 100 V for 1100 V range
- Maximum Load**50 mA for 2.2 V through 220 V ranges; 20 mA for 1100 V range; 50 Ω output impedance on 220 mV range; all ranges <1000 pF, >25 Ω
- Load Regulation**<(0.2 ppm of output + 0.1 ppm of range), full load to no load
- Line Regulation**<0.1 ppm change, ± 10 % of selected nominal line
- Settling Time**3 seconds to full accuracy; + 1 second for range or polarity change; + 1 second for 1100 V range
- Overshoot**<5 %
- Common Mode Rejection**140 dB, DC to 400 Hz
- Remote Sensing**Available 0 V to ±1100 V, on 2.2 V through 1100 V ranges

AC Voltage Specifications

5720A Series II AC Voltage Specifications: 99% Confidence Level

Range	Resolution	Frequency (Hz)	Absolute Uncertainty ± 5 °C from calibration temperature				Relative Uncertainty ± 1 °C	
			24 Hours	90 Days	180 Days	1 Year	24 Hours	90 Days
			± (ppm output + μV)					
2.2 mV	1 nV	10 - 20	250 + 5	270 + 5	290 + 5	300 + 5	250 + 5	270 + 5
		20 - 40	100 + 5	105 + 5	110 + 5	115 + 5	100 + 5	105 + 5
		40 - 20 k	85 + 5	90 + 5	95 + 5	100 + 5	60 + 5	65 + 5
		20 k - 50 k	220 + 5	230 + 5	240 + 5	250 + 5	85 + 5	95 + 5
		50 k - 100 k	500 + 6	540 + 6	570 + 6	600 + 6	200 + 6	220 + 6
		100 k - 300 k	1000 + 12	1200 + 12	1250 + 12	1300 + 12	350 + 12	400 + 12
22 mV	10 nV	300 k - 500 k	1400 + 25	1500 + 25	1600 + 25	1700 + 25	800 + 25	1000 + 25
		500 k - 1 M	2900 + 25	3100 + 25	3250 + 25	3400 + 25	2700 + 25	3000 + 25
		10 - 20	250 + 5	270 + 5	290 + 5	300 + 5	250 + 5	270 + 5
		20 - 40	100 + 5	105 + 5	110 + 5	115 + 5	100 + 5	105 + 5
		40 - 20 k	85 + 5	90 + 5	95 + 5	100 + 5	60 + 5	65 + 5
		20 k - 50 k	220 + 5	230 + 5	240 + 5	250 + 5	85 + 5	95 + 5
220 mV	100 nV	50 k - 100 k	500 + 6	540 + 6	570 + 6	600 + 6	200 + 6	220 + 6
		100 k - 300 k	1000 + 12	1200 + 12	1250 + 12	1300 + 12	350 + 12	400 + 12
		300 k - 500 k	1400 + 25	1500 + 25	1600 + 25	1700 + 25	800 + 25	1000 + 25
		500 k - 1 M	2900 + 25	3100 + 25	3250 + 25	3400 + 25	2700 + 25	3000 + 25
		10 - 20	250 + 15	270 + 15	290 + 15	300 + 15	250 + 15	270 + 15
		20 - 40	100 + 8	105 + 8	110 + 8	115 + 8	100 + 8	105 + 8
2.2 V	1 μV	40 - 20 k	85 + 8	90 + 8	95 + 8	100 + 8	60 + 8	65 + 8
		20 k - 50 k	220 + 8	230 + 8	240 + 8	250 + 8	85 + 8	95 + 8
		50 k - 100 k	500 + 20	540 + 20	570 + 20	600 + 20	200 + 20	220 + 20
		100 k - 300 k	850 + 25	900 + 25	1000 + 25	1100 + 25	350 + 25	400 + 25
		300 k - 500 k	1400 + 30	1500 + 30	1600 + 30	1700 + 30	800 + 30	1000 + 30
		500 k - 1 M	2700 + 60	2900 + 60	3100 + 60	3300 + 60	2600 + 60	2800 + 60
22 V	10 μV	10 - 20	250 + 50	270 + 50	290 + 50	300 + 50	250 + 50	270 + 50
		20 - 40	95 + 20	100 + 20	105 + 20	110 + 20	95 + 20	100 + 20
		40 - 20 k	45 + 10	47 + 10	50 + 10	52 + 10	30 + 10	40 + 10
		20 k - 50 k	80 + 12	85 + 12	87 + 12	90 + 12	70 + 12	75 + 12
		50 k - 100 k	120 + 40	125 + 40	127 + 40	130 + 40	100 + 40	105 + 40
		100 k - 300 k	380 + 100	420 + 100	460 + 100	500 + 100	270 + 100	290 + 100
220 V ^[2]	100 μV	300 k - 500 k	1000 + 250	1100 + 250	1150 + 250	1200 + 250	900 + 250	1000 + 250
		500 k - 1 M	1600 + 400	1800 + 600	1900 + 400	2000 + 400	1200 + 400	1300 + 400
		10 - 20	250 + 500	270 + 500	290 + 500	300 + 500	250 + 500	270 + 500
		20 - 40	95 + 200	100 + 200	105 + 200	110 + 200	95 + 200	100 + 200
		40 - 20 k	45 + 70	47 + 70	50 + 70	52 + 70	30 + 70	40 + 70
		20 k - 50 k	80 + 120	85 + 120	87 + 120	90 + 120	70 + 120	75 + 120
1100 V ^[1]	1 μV	50 k - 100 k	110 + 250	115 + 250	117 + 250	120 + 250	100 + 250	105 + 250
		100 k - 300 k	300 + 800	310 + 800	320 + 800	325 + 800	270 + 800	290 + 800
		300 k - 500 k	1000 + 2500	1100 + 2500	1150 + 2500	1200 + 2500	900 + 2500	1000 + 2500
		500 k - 1 M	1500 + 4000	1600 + 4000	1700 + 4000	1800 + 4000	1300 + 4000	1400 + 4000
		10 - 20	250 + 5	270 + 5	290 + 5	300 + 5	250 + 5	270 + 5
		20 - 40	95 + 2	100 + 2	105 + 2	110 + 2	95 + 2	100 + 2
5725A Amplifier:								
1100 V	1 mV	40 - 20 k	57 + 0.7	60 + 0.7	62 + 0.7	65 + 0.7	45 + 0.7	50 + 0.7
		20 k - 50 k	90 + 1.2	95 + 1.2	97 + 1.2	100 + 1.2	75 + 1.2	80 + 1.2
		50 k - 100 k	160 + 3	170 + 3	175 + 3	180 + 3	140 + 3	150 + 3
750 V	50 k - 100k	100 k - 300 k	900 + 20	1000 + 20	1050 + 20	1100 + 20	600 + 20	700 + 20
		300 k - 500 k	5000 + 50	5200 + 50	5300 + 50	5400 + 50	4500 + 50	4700 + 50
		500 k - 1 M	8000 + 100	9000 + 100	9500 + 100	10,000 + 100	8000 + 100	8500 + 100
1100 V	1 μV	15 - 50	300 + 20	320 + 20	340 + 20	360 + 20	300 + 20	320 + 20
		50 - 1 k	70 + 4	75 + 4	80 + 4	85 + 4	50 + 4	55 + 4
Notes:								
1. Maximum output 250 V from 15-50 Hz.								
2. See Volt-Hertz capability in Figure A.								

5720A Series II AC Voltage Specifications: 95 % Confidence Level

Range	Resolution	Frequency (Hz)	Absolute Uncertainty ± 5 °C from calibration temperature				Relative Uncertainty ± 1 °C	
			24 Hours	90 Days	180 Days	1 Year	24 Hours	90 Days
			± (ppm output + μV)					
2.2 mV	1 nV	10 - 20	200 + 4	220 + 4	230 + 4	240 + 4	200 + 4	220 + 4
		20 - 40	80 + 4	85 + 4	87 + 4	90 + 4	80 + 4	85 + 4
		40 - 20 k	70 + 4	75 + 4	77 + 4	80 + 4	50 + 4	55 + 4
		20 k - 50 k	170 + 4	180 + 4	190 + 4	200 + 4	70 + 4	80 + 4
		50 k - 100 k	400 + 5	460 + 5	480 + 5	500 + 5	160 + 5	180 + 5
		100 k - 300 k	300 + 10	900 + 10	1000 + 10	1050 + 10	280 + 10	320 + 10
		300 k - 500 k 500 k - 1 M	1100 + 20 2400 + 20	1200 + 20 2500 + 20	1300 + 20 2600 + 20	1400 + 20 2700 + 20	650 + 20 2100 + 20	800 + 20 2400 + 20
22 mV	10 nV	10 - 20	200 + 4	220 + 4	230 + 4	240 + 4	200 + 4	220 + 4
		20 - 40	80 + 4	85 + 4	87 + 4	90 + 4	80 + 4	85 + 4
		40 - 20 k	70 + 4	75 + 4	77 + 4	80 + 4	50 + 4	55 + 4
		20 k - 50 k	170 + 4	180 + 4	190 + 4	200 + 4	70 + 4	80 + 4
		50 k - 100 k	400 + 5	460 + 5	480 + 5	500 + 5	160 + 5	180 + 5
		100 k - 300 k	300 + 10	900 + 10	1000 + 10	1050 + 10	280 + 10	320 + 10
		300 k - 500 k 500 k - 1 M	1100 + 20 2400 + 20	1200 + 20 2500 + 20	1300 + 20 2600 + 20	1400 + 20 2700 + 20	650 + 20 2100 + 20	800 + 20 2400 + 20
220 mV	100 nV	10 - 20	200 + 12	220 + 12	230 + 12	240 + 12	200 + 12	220 + 12
		20 - 40	80 + 7	85 + 7	87 + 7	90 + 7	80 + 7	85 + 7
		40 - 20 k	70 + 7	75 + 7	77 + 7	80 + 7	50 + 7	55 + 7
		20 k - 50 k	170 + 7	180 + 7	190 + 7	200 + 7	70 + 7	80 + 7
		50 k - 100 k	400 + 17	420 + 17	440 + 17	460 + 17	160 + 17	180 + 17
		100 k - 300 k	700 + 20	750 + 20	800 + 20	900 + 20	280 + 20	320 + 20
		300 k - 500 k 500 k - 1 M	1100 + 25 2400 + 45	1200 + 25 2500 + 45	1300 + 25 2600 + 45	1400 + 25 2700 + 45	650 + 25 2100 + 45	800 + 25 2400 + 45
2.2 V	1 mV	10 - 20	200 + 40	220 + 40	230 + 40	240 + 40	200 + 40	220 + 40
		20 - 40	75 + 15	80 + 15	85 + 15	90 + 15	75 + 15	80 + 15
		40 - 20 k	37 + 8	40 + 8	42 + 8	45 + 8	25 + 8	35 + 8
		20 k - 50 k	65 + 10	70 + 10	73 + 10	75 + 10	55 + 10	60 + 10
		50 k - 100 k	100 + 30	105 + 30	107 + 30	110 + 30	80 + 30	85 + 30
		100 k - 300 k	300 + 80	340 + 80	380 + 80	420 + 80	230 + 80	250 + 80
		300 k - 500 k 500 k - 1 M	800 + 200 1300 + 300	900 + 200 1500 + 300	950 + 200 1600 + 300	1000 + 200 1700 + 300	700 + 200 1000 + 300	800 + 200 1100 + 300
22 V	10 mV	10 - 20	200 + 400	220 + 400	230 + 400	240 + 400	200 + 400	220 + 400
		20 - 40	75 + 150	80 + 150	85 + 150	90 + 150	75 + 150	80 + 150
		40 - 20k	37 + 50	40 + 50	42 + 50	45 + 50	25 + 50	35 + 50
		20k - 50k	65 + 100	70 + 100	73 + 100	75 + 100	55 + 100	60 + 100
		50k - 100k	90 + 200	95 + 200	97 + 200	100 + 200	80 + 200	85 + 200
		100k - 300k	250 + 600	260 + 600	270 + 600	275 + 600	250 + 600	270 + 600
		300k - 500k 500k - 1M	800 + 2000 1200 + 3200	900 + 2000 1300 + 3200	900 + 2000 1400 + 3200	1000 + 2000 1500 + 3200	700 + 2000 1100 + 3200	800 + 2000 1200 + 3200
± (ppm output + mV)								
220 V ^[2]	100 mV	10 - 20	200 + 4	220 + 4	230 + 4	240 + 4	200 + 4	220 + 4
		20 - 40	75 + 1.5	80 + 1.5	85 + 1.5	90 + 1.5	75 + 1.5	80 + 1.5
		40 - 20 k	45 + 0.6	47 + 0.6	50 + 0.6	52 + 0.6	35 + 0.6	40 + 0.6
		20 k - 50 k	70 + 1	75 + 1	77 + 1	80 + 1	60 + 1	65 + 1
		50 k - 100 k	120 + 2.5	130 + 2.5	140 + 2.5	150 + 2.5	110 + 2.5	120 + 2.5
		100 k - 300 k	700 + 16	800 + 16	850 + 16	900 + 16	500 + 16	600 + 16
		300 k - 500 k 500 k - 1 M	4000 + 40 6000 + 80	4200 + 40 7000 + 80	4300 + 40 7500 + 80	4400 + 40 8000 + 80	3600 + 40 6500 + 80	3800 + 40 7000 + 80
1100 V ^[1]	1 mV	15 - 50	240 + 16	260 + 16	280 + 16	300 + 16	240 + 16	260 + 16
		50 - 1 k	55 + 3.5	60 + 3.5	65 + 3.5	70 + 3.5	40 + 3.5	45 + 3.5
5725A Amplifier:								
1100 V	1 mV	40 - 1 k	75 + 4	80 + 4	85 + 4	90 + 4	50 + 4	55 + 4
		1 k - 20 k	105 + 6	125 + 6	135 + 6	165 + 6	85 + 6	105 + 6
		20 k - 30 k	230 + 11	360 + 11	440 + 11	600 + 11	160 + 11	320 + 11
750 V		30 k - 50 k	230 + 11	360 + 11	440 + 11	600 + 11	160 + 11	320 + 11
		50 k - 100 k	600 + 45	1300 + 45	1600 + 45	2300 + 45	380 + 45	1200 + 45
Notes:								
1. Maximum output 250 V from 15-50 Hz.								
2. See Volt-Hertz capability in Figure A.								

5700A Series II AC Voltage Specifications: 99 % Confidence Level

Range	Resolution	Frequency (Hz)	Absolute Uncertainty ± 5 °C from calibration temperature				Relative Uncertainty ± 1 °C	
			24 Hours	90 Days	180 Days	1 Year	24 Hours	90 Days
			± (ppm output + μV)					
2.2 mV	1 nV	10 - 20	500 + 5	550 + 5	600 + 5	600 + 5	500 + 5	550 + 5
		20 - 40	200 + 5	220 + 5	230 + 5	240 + 5	200 + 5	220 + 5
		40 - 20 k	100 + 5	110 + 5	120 + 5	120 + 5	60 + 5	65 + 5
		20 k - 50 k	340 + 5	370 + 5	390 + 5	410 + 5	100 + 5	110 + 5
		50 k - 100 k	800 + 8	900 + 8	950 + 8	950 + 8	220 + 8	240 + 8
		100 k - 300 k	1100 + 15	1200 + 15	1300 + 15	1300 + 15	400 + 15	440 + 15
		300 k - 500 k	1500 + 30	1700 + 30	1700 + 30	1800 + 30	1000 + 30	1100 + 30
500 k - 1 M	4000 + 40	4400 + 40	4700 + 40	4800 + 40	400 + 30	4400 + 30		
22 mV	10 nV	10 - 20	500 + 6	550 + 6	600 + 6	600 + 6	500 + 6	550 + 6
		20 - 40	200 + 6	220 + 6	230 + 6	240 + 6	200 + 6	220 + 6
		40 - 20 k	100 + 6	110 + 6	120 + 6	120 + 6	60 + 6	65 + 6
		20 k - 50 k	340 + 6	370 + 6	390 + 6	410 + 6	100 + 6	110 + 6
		50 k - 100 k	800 + 8	900 + 8	950 + 8	950 + 8	220 + 8	240 + 8
		100 k - 300 k	1100 + 15	1200 + 15	1300 + 15	1300 + 15	400 + 15	440 + 15
		300 k - 500 k	1500 + 30	1700 + 30	1700 + 30	1800 + 30	1000 + 30	1100 + 30
500 k - 1 M	4000 + 40	4400 + 40	4700 + 40	4800 + 40	4000 + 30	4400 + 30		
220 mV	100 nV	10 - 20	500 + 16	550 + 16	600 + 16	600 + 16	500 + 16	550 + 16
		20 - 40	200 + 10	220 + 10	230 + 10	240 + 10	200 + 10	220 + 10
		40 - 20 k	95 + 10	100 + 10	110 + 10	110 + 10	60 + 10	65 + 10
		20 k - 50 k	300 + 10	330 + 10	350 + 10	360 + 10	100 + 10	110 + 10
		50 k - 100 k	750 + 30	800 + 30	850 + 30	900 + 30	220 + 30	240 + 30
		100 k - 300 k	940 + 30	1000 + 30	1100 + 30	1100 + 30	400 + 30	440 + 30
		300 k - 500 k	1500 + 40	1700 + 40	1700 + 40	1800 + 40	1000 + 40	1100 + 40
500 k - 1 M	3000 + 100	3300 + 100	3500 + 100	3600 + 100	3000 + 100	3300 + 100		
2.2 V	1 mV	10 - 20	500 + 100	550 + 100	600 + 100	600 + 100	500 + 100	550 + 100
		20 - 40	150 + 30	170 + 30	170 + 30	180 + 30	150 + 30	170 + 30
		40 - 20 k	70 + 7	75 + 7	80 + 7	85 + 7	40 + 7	45 + 7
		20 k - 50 k	120 + 20	130 + 20	140 + 20	140 + 20	100 + 20	110 + 20
		50 k - 100 k	230 + 80	250 + 80	270 + 80	280 + 80	200 + 80	220 + 80
		100 k - 300 k	400 + 150	440 + 150	470 + 150	480 + 150	400 + 150	440 + 150
		300 k - 500 k	1000 + 400	1100 + 400	1200 + 400	1200 + 400	1000 + 400	1100 + 400
500 k - 1 M	2000 + 1000	2200 + 1000	2300 + 1000	2400 + 1000	2000 + 1000	2200 + 1000		
22 V	10 mV	10 - 20	500 + 1000	550 + 1000	600 + 1000	600 + 1000	500 + 1000	550 + 1000
		20 - 40	150 + 300	170 + 300	170 + 300	180 + 300	150 + 300	170 + 300
		40 - 20 k	70 + 70	75 + 70	80 + 70	85 + 70	40 + 70	45 + 70
		20 k - 50 k	120 + 200	130 + 200	140 + 200	140 + 200	100 + 200	110 + 200
		50 k - 100 k	230 + 400	250 + 400	270 + 400	280 + 400	200 + 400	220 + 400
		100 k - 300 k	500 + 1700	550 + 1700	550 + 1700	600 + 1700	500 + 1700	550 + 1700
		300 k - 500 k	1200 + 5000	1300 + 5000	1300 + 5000	1400 + 5000	1200 + 5000	1300 + 5000
500 k - 1 M	2600 + 9000	2800 + 9000	2900 + 9000	3000 + 9000	2600 + 9000	2800 + 9000		
± (ppm output + mV)								
220 V ^[2]	100 mV	10 - 20	500 + 10	550 + 10	600 + 10	600 + 10	500 + 10	550 + 10
		20 - 40	150 + 3	170 + 3	170 + 3	180 + 3	150 + 3	170 + 3
		40 - 20 k	75 + 1	80 + 1	85 + 1	90 + 1	45 + 1	50 + 1
		20 k - 50 k	200 + 4	220 + 4	240 + 4	250 + 4	100 + 1	110 + 1
		50 k - 100 k	500 + 10	550 + 10	600 + 10	600 + 10	300 + 10	330 + 10
		100 k - 300 k	1500 + 110	1500 + 110	1600 + 110	1600 + 110	1500 + 110	1500 + 100
		300 k - 500 k	5000 + 110	5200 + 110	5300 + 110	5400 + 110	5000 + 110	5200 + 110
500 k - 1 M	12,000 + 220	12,500 + 220	12,500 + 220	13,000 + 220	12,000 + 220	12,000 + 220		
1100 V ^[1]	1 mV	15 - 50	400 + 20	420 + 20	440 + 20	460 + 20	400 + 20	420 + 20
		50 - 1 k	75 + 4	80 + 4	85 + 4	90 + 4	50 + 4	55 + 4
5725A Amplifier:								
1100 V	1 mV	40 - 1 k	75 + 4	80 + 4	85 + 4	90 + 4	50 + 4	55 + 4
		1 k - 20 k	105 + 6	125 + 6	135 + 6	165 + 6	85 + 6	105 + 6
		20 k - 30 k	230 + 11	360 + 11	440 + 11	600 + 11	160 + 11	320 + 11
750 V		30 k - 50 k	230 + 11	360 + 11	440 + 11	600 + 11	160 + 11	320 + 11
		50 k - 100 k	600 + 45	1300 + 45	1600 + 45	2300 + 45	380 + 45	1200 + 45
Notes:								
1. Maximum output 250 V from 15-50 Hz.								
2. See Volt-Hertz capability in Figure A.								

5700A Series II AC Voltage Specifications: 95 % Confidence Level

Range	Resolution	Frequency (Hz)	Absolute Uncertainty ± 5 °C from calibration temperature				Relative Uncertainty ± 1 °C	
			24 Hours	90 Days	180 Days	1 Year	24 Hours	90 Days
			± (ppm output + μV)					
2.2 mV	1 nV	10 - 20	400 + 4.5	500 + 4.5	530 + 4.5	550 + 4.5	400 + 4.5	500 + 4.5
		20 - 40	170 + 4.5	190 + 4.5	200 + 4.5	210 + 4.5	170 + 4.5	190 + 4.5
		40 - 20 k	85 + 4.5	95 + 4.5	100 + 4.5	105 + 4.5	55 + 4.5	60 + 4.5
		20 k - 50 k	300 + 4.5	330 + 4.5	350 + 4.5	370 + 4.5	90 + 4.5	100 + 4.5
		50 k - 100 k	700 + 7	750 + 7	800 + 7	850 + 7	210 + 7	230 + 7
		100 k - 300 k	900 + 13	1000 + 13	1050 + 13	1100 + 13	380 + 13	420 + 13
		300 k - 500 k	1300 + 25	1500 + 25	1600 + 25	1700 + 25	900 + 25	1000 + 25
		500 k - 1 M	2800 + 25	3100 + 25	3300 + 25	3400 + 25	2900 + 25	3200 + 25
22 mV	10 nV	10 - 20	400 + 5	500 + 5	530 + 5	550 + 5	400 + 5	500 + 5
		20 - 40	170 + 5	190 + 5	200 + 5	210 + 5	170 + 5	190 + 5
		40 - 20 k	85 + 5	95 + 5	100 + 5	105 + 5	55 + 5	60 + 5
		20 k - 50 k	300 + 5	330 + 5	350 + 5	370 + 5	90 + 5	100 + 5
		50 k - 100 k	700 + 7	750 + 7	800 + 7	850 + 7	210 + 7	230 + 7
		100 k - 300 k	900 + 12	1000 + 12	1050 + 12	1100 + 12	380 + 12	420 + 12
		300 k - 500 k	1300 + 25	1500 + 25	1600 + 25	1700 + 25	900 + 25	1000 + 25
		500 k - 1 M	2800 + 25	3100 + 25	3300 + 25	3400 + 25	2900 + 25	3200 + 25
220 mV	100 nV	10 - 20	400 + 13	500 + 13	530 + 13	550 + 13	400 + 13	500 + 13
		20 - 40	170 + 8	190 + 8	200 + 8	210 + 8	170 + 8	190 + 8
		40 - 20 k	85 + 8	95 + 8	100 + 8	105 + 8	55 + 8	60 + 8
		20 k - 50 k	250 + 8	280 + 8	300 + 8	320 + 8	90 + 8	100 + 8
		50 k - 100 k	700 + 25	750 + 25	800 + 25	850 + 25	210 + 25	230 + 25
		100 k - 300 k	900 + 25	1000 + 25	1050 + 25	1100 + 25	380 + 25	420 + 25
		300 k - 500 k	1300 + 35	1500 + 35	1600 + 35	1700 + 35	900 + 35	1000 + 35
		500 k - 1 M	2800 + 80	3100 + 80	3300 + 80	3400 + 80	2900 + 80	3200 + 80
2.2 V	1 mV	10 - 20	400 + 80	450 + 80	480 + 80	500 + 80	400 + 80	450 + 80
		20 - 40	130 + 25	140 + 25	150 + 25	160 + 25	130 + 25	140 + 25
		40 - 20 k	60 + 6	65 + 6	70 + 6	75 + 6	35 + 6	40 + 6
		20 k - 50 k	105 + 16	110 + 16	115 + 16	120 + 16	85 + 16	95 + 16
		50 k - 100 k	190 + 70	210 + 70	230 + 70	250 + 70	170 + 70	190 + 70
		100 k - 300 k	350 + 130	390 + 130	420 + 130	430 + 130	340 + 130	380 + 130
		300 k - 500 k	850 + 350	950 + 350	1000 + 350	1050 + 350	850 + 350	950 + 350
		500 k - 1 M	1700 + 850	1900 + 850	2100 + 850	2200 + 850	1700 + 850	1900 + 850
22 V	10 mV	10 - 20	400 + 800	450 + 800	480 + 800	500 + 800	400 + 800	450 + 800
		20 - 40	130 + 250	140 + 250	150 + 250	160 + 250	130 + 250	140 + 250
		40 - 20 k	60 + 60	65 + 60	70 + 60	75 + 60	35 + 60	40 + 60
		20 k - 50 k	105 + 160	110 + 160	115 + 160	120 + 160	85 + 160	95 + 160
		50 k - 100 k	190 + 350	210 + 350	230 + 350	250 + 350	170 + 350	190 + 350
		100 k - 300 k	400 + 1500	450 + 1500	470 + 1500	500 + 1500	400 + 1500	450 + 1500
		300 k - 500 k	1050 + 4300	1150 + 4300	1200 + 4300	1250 + 4300	1000 + 4300	1100 + 4300
		500 k - 1 M	2300 + 8500	2500 + 8500	2600 + 8500	2700 + 8500	2300 + 8500	2400 + 8500
± (ppm output + mV)								
220 V ^[2]	100 mV	10 - 20	400 + 8	450 + 8	480 + 8	500 + 8	400 + 8	450 + 8
		20 - 40	130 + 2.5	140 + 2.5	150 + 2.5	160 + 2.5	130 + 2.5	140 + 2.5
		40 - 20 k	65 + 0.8	70 + 0.8	75 + 0.8	80 + 0.8	40 + 0.8	45 + 0.8
		20 k - 50 k	170 + 3.5	190 + 3.5	210 + 3.5	220 + 3.5	85 + 3.5	95 + 3.5
		50 k - 100 k	400 + 8	450 + 8	480 + 8	500 + 8	270 + 8	300 + 8
		100 k - 300 k	1300 + 90	1400 + 90	1450 + 90	1500 + 90	1200 + 90	1300 + 90
		300 k - 500 k	4300 + 90	4500 + 90	4600 + 90	4700 + 90	4200 + 90	4500 + 90
		500 k - 1 M	10,500 + 190	11,000 + 190	11,300 + 190	11,500 + 190	10,500 + 190	11,000 + 190
1100 V ^[1]	1 mV	15 - 50	340 + 16	360 + 16	380 + 16	400 + 16	340 + 16	360 + 16
		50 - 1 k	65 + 3.5	70 + 3.5	75 + 3.5	80 + 3.5	45 + 3.5	50 + 3.5
5725A Amplifier:								
1100 V	1 mV	40 - 1 k	75 + 4	80 + 4	85 + 4	90 + 4	50 + 4	55 + 4
		1 k - 20 k	105 + 6	125 + 6	135 + 6	165 + 6	85 + 6	105 + 6
		20 k - 30 k	230 + 11	360 + 11	440 + 11	600 + 11	160 + 11	320 + 11
750 V		30 k - 50 k	230 + 11	360 + 11	440 + 11	600 + 11	160 + 11	320 + 11
		50 k - 100 k	600 + 45	1300 + 45	1600 + 45	2300 + 45	380 + 45	1200 + 45
Notes:								
1. Maximum output 250 V from 15-50 Hz.								
2. See Volt-Hertz capability in Figure A.								

AC Voltage Secondary Performance Specifications and Operating Characteristics

Range	Frequency (Hz)	Stability ± 1 °C ^[1] 24 Hours	Temperature Coefficient		Output Impedance (Ω)	Maximum Distortion Bandwidth 10 Hz-10 MHz
			10 - 40 °C	0 - 10 °C and 40 - 50 °C		
			±μV / °C			
2.2 mV	10 - 20	5	0.05	0.05	50	0.05 + 10
	20 - 40	5	0.05	0.05		0.035 + 10
	40 - 20 k	2	0.05	0.05		0.035 + 10
	20 k - 50 k	2	0.1	0.1		0.035 + 10
	50 k - 100 k	3	0.2	0.2		0.035 + 30
	100 k - 300 k	3	0.3	0.3		0.3 + 30
	300 k - 500 k	5	0.4	0.4		0.3 + 30
	500 k - 1 M	5	0.5	0.5		2 + 50
22 mV	10 - 20	5	0.2	0.3	50	0.05 + 11
	20 - 40	5	0.2	0.3		0.035 + 11
	40 - 20 k	2	0.2	0.3		0.035 + 11
	20 k - 50 k	2	0.4	0.5		0.035 + 11
	50 k - 100 k	3	0.5	0.5		0.035 + 30
	100 k - 300 k	5	0.6	0.6		0.3 + 30
	300 k - 500 k	10	1	1		0.3 + 30
	500 k - 1 M	15	1	1		2 + 30
		± (ppm output + μV)	± (ppm output μV) / °C			
220 mV	10 - 20	150 + 20	2 + 1	2 + 1	50	0.05 + 16
	20 - 40	80 + 15	2 + 1	2 + 1		0.035 + 16
	40 - 20 k	12 + 2	2 + 1	2 + 1		0.035 + 16
	20 k - 50 k	10 + 2	15 + 2	15 + 2		0.035 + 16
	50 k - 100 k	10 + 2	15 + 4	15 + 4		0.035 + 30
	100 k - 300 k	20 + 4	80 + 5	80 + 5		0.3 + 30
	300 k - 500 k	100 + 10	80 + 5	80 + 5		0.3 + 30
	500 k - 1 M	200 + 20	80 + 5	80 + 5		1 + 30
					Load Regulation ±(ppm output+ μV)	
2.2 V	10 - 20	150 + 20	50 + 10	50 + 10	10 + 2	0.05 + 80
	20 - 40	80 + 15	15 + 5	15 + 5	10 + 2	0.035 + 80
	40 - 20 k	12 + 4	2 + 1	5 + 2	10 + 4	0.035 + 80
	20 k - 50 k	15 + 5	10 + 2	15 + 4	30 + 10	0.035 + 80
	50 k - 100 k	15 + 5	10 + 4	20 + 4	120 + 16	0.035 + 110
	100 k - 300 k	30 + 10	80 + 15	80 + 15	300 ppm	0.3 + 110
	300 k - 500 k	70 + 20	80 + 40	80 + 40	600 ppm	0.5 + 110
	500 k - 1 M	150 + 50	80 + 100	80 + 100	1200 ppm	1 + 110
22 V	10 - 20	150 + 20	50 + 100	50 + 100	10 + 20	0.05 + 700
	20 - 40	80 + 15	15 + 30	15 + 40	10 + 20	0.035 + 700
	40 - 20 k	12 + 8	2 + 10	4 + 15	10 + 30	0.035 + 700
	20 k - 50 k	15 + 10	10 + 20	20 + 20	30 + 50	0.035 + 700
	50 k - 100 k	15 + 10	10 + 40	20 + 40	80 + 80	0.05 + 800
	100 k - 300 k	30 + 15	80 + 150	80 + 150	100 + 700	0.3 + 800
	300 k - 500 k	70 + 100	80 + 300	80 + 300	200 + 1100	0.3 + 800
	500 k - 1 M	150 + 100	80 + 500	80 + 500	600 + 3000	2 + 800
220 V	10 - 20	150 + 200	50 + 1000	50 + 1000	10 + 200	0.05 + 10,000
	20 - 40	80 + 150	15 + 300	15 + 300	10 + 200	0.05 + 10,000
	40 - 20 k	12 + 80	2 + 80	4 + 80	10 + 300	0.05 + 10,000
	20 k - 50 k	15 + 100	10 + 100	20 + 100	30 + .600	0.05 + 10,000
	50 k - 100 k	15 + 100	10 + 500	20 + 500	80 + 3,000	0.2 + 50,000
	100 k - 300 k	30 + 400	80 + 600	80 + 600	250 + 25,000	1.5 + 50,000
	300 k - 500 k	100 + 10,000	80 + 800	80 + 800	500 + 50,000	1.5 + 50,000
	500 k - 1 M	200 + 20,000	80 + 1000	80 + 1000	1000 + 110,000	3.5 + 100,000
		±(ppm output + mV)	±(ppm output) / °C		±(ppm output + mV)	±(% output)
1100 V	15 - 50	150 + 0.5	50	50	10 + 2	0.15
	50 - 1 k	20 + 0.5	2	5	10 + 1	0.07

5725A Amplifier:							
Range	Frequency (Hz)	Stability $\pm 1^\circ\text{C}^{[1]}$ 24 Hours	Temperature Coefficient Adder		Load Regulation ^[2]	Distortion Bandwidth 10 Hz - 10 MHz $\pm(\% \text{ output})$	
			10 - 40 °C	0 - 10 °C and 40 - 50 °C		150 pF	1000 pF
		$\pm(\text{ppm output} + \text{mV})$	$\pm(\text{ppm output}) / ^\circ\text{C}$		$\pm(\text{ppm output} + \text{mV})$		
1100 V	40 - 1 k	10 + .5	5	5	10 + 1	0.10	0.10
	1 k - 20 k	15 + 2	5	5	90 + 6	0.10	0.15
	20 k - 50 k	40 + 2	10	10	275 + 11	0.30	0.30
	50 k - 100 k	130 + 2	30	30	500 + 30	0.40	0.40
Notes:							
1. Stability specifications are included in Absolute Uncertainty values for the primary specifications.							
2. The 5725A will drive up to 1000 pF of load capacitance. Uncertainty specifications include loads to 300 pF and 150 pF as shown under "Load Limits." For capacitances up to the maximum of 1000 pF, add "Load Regulation."							

Voltage Range	Maximum Current Limits	Load Limits
2.2 V ^[2]		
22 V	50 mA, 0 °C-40 °C	>50 Ω ,
220 V	20 mA, 40 °C-50 °C	1000 pF
1100 V	6 mA	600 pF
5725A Amplifier:		
1100 V	40 Hz-5 kHz	50 mA
	5 kHz-30 kHz	70 mA
	30 kHz-100 kHz	70 mA ^[3]
		1000 pF ^[1]
		300 pF
		150 pF
Notes:		
1. The 5725A will drive up to 1000 pF of load capacitance. Uncertainty specifications include loads to 300 pF and 150 pF as shown under "Load Limits." For capacitances up to the maximum of 1000 pF, add "Load Regulation."		
2. 2.2 V Range, 100 kHz-1.2 MHz only: uncertainty specifications cover loads to 10 mA or 1000 pF. For higher loads, load regulation is added.		
3. Applies from 0 °C to 40 °C.		

Output Display Formats Voltage or dBm, dBm reference 600 Ω .

Minimum Output 10 % on each range

External Sense Selectable for 2.2 V, 22 V, 220 V, and 1100 V ranges; 5700A/5720A <100 kHz, 5725A <30 kHz

Settling Time to Full Accuracy

Frequency (Hz)	Settling Time (seconds)
<20	7
120-120 k	5
>120 k	2
Notes:	
Plus 1 second for amplitude or frequency range change	
Plus 2 seconds for 5700A/5720A 1100 V range	
Plus 4 seconds for 5725A 1100 V range	

Resistance Specifications

5720A Series II Resistance Specifications

Nominal Value (Ω)	Absolute Uncertainty of Characterized Value $\pm 5^\circ\text{C}$ from calibration temperature ^[1]				Relative Uncertainty $\pm 1^\circ\text{C}$	
	24 Hours	90 Days	180 Days	1 Year	24 Hours	90 Days
	$\pm\text{ppm}$					
99 % Confidence Level						
0	50 $\mu\Omega$	50 $\mu\Omega$	50 $\mu\Omega$	50 $\mu\Omega$	50 $\mu\Omega$	50 $\mu\Omega$
1	85	95	100	110	32	40
1.9	85	95	100	110	25	33
10	23	25	26	27	5	8
19	23	25	26	27	4	7
100	10	11	11.5	12	2	4
190	10	11	11.5	12	2	4
1 k	8	9	9.5	10	2	3
1.9 k	8	9	9.5	10	2	3
10 k	8	9	9.5	10	2	3
19 k	9	9	9.5	10	2	3
100 k	9	11	12	13	2	3
190 k	9	11	12	13	2	3
1 M	16	18	20	23	2.5	5
1.9 M	1	19	21	24	3	6
10 M	33	37	40	46	10	14
19 M	43	47	50	55	20	24
100 M	100	110	115	120	50	60
95 % Confidence Level						
0	40 $\mu\Omega$	40 $\mu\Omega$	40 $\mu\Omega$	40 $\mu\Omega$	40 $\mu\Omega$	40 $\mu\Omega$
1	70	80	85	95	27	35
1.9	70	80	85	95	20	26
10	20	21	22	23	4	7
19	20	21	22	23	3.5	6
100	8	9	9.5	10	1.6	3.5
190	8	9	9.5	10	1.6	3.5
1 k	6.5	7.5	8	8.5	1.6	2.5
1.9 k	6.5	7.5	8	8.5	1.6	2.5
10 k	6.5	7.5	8	8.5	1.6	2.5
19 k	7.5	7.5	8	8.5	1.6	2.5
100 k	7.5	9	10	11	1.6	2.5
190 k	7.5	9	10	11	1.6	2.5
1 M	13	15	17	20	2	4
1.9 M	14	16	18	21	2.5	4
10 M	27	31	34	40	8	12
19 M	35	39	42	47	16	20
100 M	85	95	100	100	40	50
Note:						
1. Specifications apply to displayed value. 4-wire connections, except 100 M Ω .						

5700A Series II Resistance Specifications

Nominal Value (Ω)	Absolute Uncertainty of Characterized Value $\pm 5^\circ\text{C}$ from calibration temperature ⁽¹⁾				Relative Uncertainty $\pm 1^\circ\text{C}$	
	24 Hours	90 Days	180 Days	1 Year	24 Hours	90 Days
	$\pm\text{ppm}$					
99 % Confidence Level						
0	50 $\mu\Omega$	50 $\mu\Omega$	50 $\mu\Omega$	50 $\mu\Omega$	50 $\mu\Omega$	50 $\mu\Omega$
1	85	95	100	110	32	40
1.9	85	95	100	110	25	33
10	26	28	30	33	5	8
19	24	26	28	31	4	7
100	15	17	18	20	2	4
190	15	17	18	20	2	4
1 k	11	12	13	15	2	3.5
1.9 k	11	12	13	15	2	3.5
10 k	9	11	12	14	2	3.5
19 k	9	11	12	14	2	3.5
100 k	11	13	14	16	2	3.5
190 k	11	13	14	16	2	3.5
1 M	16	18	20	23	2.5	5
1.9 M	17	19	21	24	3.5	6
10 M	33	37	40	46	10	14
19 M	43	47	50	55	20	24
100 M	110	120	125	130	50	60
95 % Confidence Level						
0	50 $\mu\Omega$	50 $\mu\Omega$	50 $\mu\Omega$	50 $\mu\Omega$	50 $\mu\Omega$	50 $\mu\Omega$
1	70	80	85	95	32	40
1.9	70	80	85	95	25	33
10	21	23	27	28	5	8
19	20	22	24	27	4	7
100	13	14	15	17	2	4
190	13	14	15	17	2	4
1 k	9	10	11	13	2	3.5
1.9 k	9	10	11	13	2	3.5
10 k	7.5	9.5	10.5	12	2	3.5
19 k	7.5	9.5	10.5	12	2	3.5
100 k	9	11	12	14	2	3.5
190 k	9	11	12	14	2	3.5
1 M	13	15	17	20	2.5	5
1.9 M	14	16	18	21	3	6
10 M	27	31	34	40	10	14
19 M	35	39	42	47	20	24
100 M	90	100	105	110	50	60
Note:						
1. Specifications apply to displayed value. 4-wire connections, except 100 M Ω .						

Resistance Secondary Performance Specifications and Operating Characteristics

Nominal Value (Ω)	Stability ±1 °C [1] 24 Hours	Temperature Coefficient Adder [2]		Full Spec Load Range [3] I _L - I _H (mA)	Maximum Peak Current I _{MAX} (mA)	Maximum Difference of Characterized to Nominal Value	Two-Wire Adder Active Compensation [4]	
		10 - 40 °C	0 - 10 °C and 40 - 50 °C				Lead Resistance	
		±ppm/°C					0.1 Ω	1 Ω
±ppm						±ppm	±mΩ	
0	—	—	—	8 - 500	500	—	$2 + \frac{4\mu V}{I_m}$	$4 + \frac{4\mu V}{I_m}$
1	32	4	5	8 - 100	700	500	$2 + \frac{4\mu V}{I_m}$	$4 + \frac{4\mu V}{I_m}$
1.9	25	6	7	8 - 100	500	500	$2 + \frac{4\mu V}{I_m}$	$4 + \frac{4\mu V}{I_m}$
10	5	2	3	8 - 11	220	300	$2 + \frac{4\mu V}{I_m}$	$4 + \frac{4\mu V}{I_m}$
19	4	2	3	8 - 11	160	300	$2 + \frac{4\mu V}{I_m}$	$4 + \frac{4\mu V}{I_m}$
100	2	2	3	8 - 11	70	150	$2 + \frac{4\mu V}{I_m}$	$4 + \frac{4\mu V}{I_m}$
190	2	2	3	8 - 11	50	150	$2 + \frac{4\mu V}{I_m}$	$4 + \frac{4\mu V}{I_m}$
1 k	2	2	3	1 - 2	22	150	10	15
1.9 k	2	2	3	1 - 1.5	16	150	10	15
10 k	2	2	3	100 - 500 μA	7	150	50	60
19 k	2	2	3	50 - 250 μA	5	150	100	120
100 k	2	2	3	10 - 100 μA	1	150	I _m = Current produced by Ohmmeter (A)	
190 k	2	2	3	5 - 50 μA	500 μA	150		
1 M	2.5	2.5	6	5 - 20 μA	100 μA	200		
1.9 M	3.5	3	10	2.5 - 10 μA	50 μA	200		
10 M	10	5	20	0.5 - 2 μA	10 μA	300		
19 M	20	8	40	0.25 - 1 μA	5 μA	300		
100 M	50	12	100	50 - 200 nA	1 μA	500		

Notes:

- Stability specifications are included in the Absolute Uncertainty values in the primary specification tables.
- Temperature coefficient is an adder to uncertainty specifications that does not apply unless operated more than 5 °C from calibration temperature, or calibrated outside the range 19 °C to 24 °C. Two examples:
 - Calibrate at 20 °C: Temperature coefficient adder is not required unless operated below 15 °C or above 25 °C.
 - Calibrate at 26 °C: Add 2 °C temperature coefficient adder. Additional temperature coefficient adder is not required unless operated below 21 °C or above 31 °C.
- Refer to current derating factors table for loads outside of this range.
- Active two-wire compensation may be selected for values less than 100 kΩ, with either the front panel or the meter input terminals as reference plane. Active compensation is limited to 11 mA load, and to 2 V burden. Two-wire compensation can be used only with Ω-meters that source continuous (not pulsed) dc current.

Current Derating Factors

Nominal Value (Ω)	Value of Derating Factor K for Over or Under Current		
	Two-Wire Comp $I < I_L$ ^[1]	Four-Wire $I < I_L$ ^[1]	Four-Wire $I_U < I < I_{MAX}$ ^[2]
SHORT	4.4	0.3	—
1	4.4	300	4×10^{-5}
1.9	4.4	160	1.5×10^{-4}
10	4.4	30	1.6×10^{-3}
19	4.4	16	3×10^{-3}
100	4.4	3.5	1×10^{-2}
190	4.4	2.5	1.9×10^{-2}
1 k	4.4	0.4	0.1
1.9 k	4.4	0.4	0.19
10 k	5000	50	2.0
19 k	5000	50	3.8
100 k	—	7.5	2×10^{-5}
190 k	—	4.0	3.8×10^{-5}
1 M	—	1.0	1.5×10^{-4}
1.9 M	—	0.53	2.9×10^{-4}
10 M	—	0.2	1×10^{-3}
19 M	—	0.53	1.9×10^{-3}
100 M	—	0.1	—

Notes:

- For $I < I_L$, errors occur due to thermally generated voltages within the 5720A. Use the following equation to determine the error, and add this error to the corresponding uncertainty or stability specification.

$$\text{Error} = K(I_L - I) / (I_L \times I)$$

Where: Error is in mΩ for all two-wire comp values and four-wire short, and in ppm for the remaining four-wire values.

K is the constant from the above table;

I and I_L are expressed in mA for short to 1.9 kΩ;

I and I_L are expressed in μA for 10 kΩ to 100 MΩ

- For $I_U < I < I_{MAX}$, errors occur due to self-heating of the resistors in the calibrator. Use the following equation to determine the error in ppm and add this error to the corresponding uncertainty or stability specification.

$$\text{Error in ppm} = K(I^2 - I_U^2)$$

Where: K is the constant from the above table;

I and I_U are expressed in mA for short to 19 kΩ;

I and I_U are expressed in μA for 100 kΩ to 100 MΩ

DC Current Specifications

5720A Series II DC Current Specifications

Range	Resolution	Absolute Uncertainty ±5 °C from calibration temperature ^[2]				Relative Uncertainty ±1 °C	
		24 Hours	90 Days	180 Days	1 Year	24 Hours	90 Days
		± (ppm output + nA)					
99 % Confidence Level							
220 µA	0	40 + 7	42 + 7	45 + 7	50 + 7	24 + 2	26 + 2
2.2 mA	1	30 + 8	35 + 8	37 + 8	40 + 8	24 + 5	26 + 5
22 mA	10	30 + 50	35 + 50	37 + 50	40 + 50	24 + 50	26 + 50
		± (ppm output + µA)					
220 mA ^[1]	0.1	40 + 0.8	45 + 0.8	47 + 0.8	50 + 0.8	26 + 0.3	30 + 0.3
2.2 A ^[1]	1	60 + 15	70 + 15	80 + 15	90 + 15	40 + 7	45 + 7
5725A Amplifier:							
11 A	10	330 + 470	340 + 480	350 + 480	360 + 480	100 + 130	110 + 130
95 % Confidence Level							
		± (ppm output + nA)					
220 µA	0.1	32 + 6	35 + 6	37 + 6	40 + 6	20 + 1.6	22 + 1.6
2.2 mA	1	25 + 7	30 + 7	33 + 7	35 + 7	20 + 4	22 + 4
22 mA	10	25 + 40	30 + 40	33 + 40	35 + 40	20 + 40	22 + 40
		± (ppm output + µA)					
220 mA ^[1]	0.1	35 + 0.7	40 + 0.7	42 + 0.7	45 + 0.7	22 + 0.25	25 + 0.25
2.2 A ^[1]	1	50 + 12	60 + 12	70 + 12	80 + 12	35 + 6	40 + 6
5725A Amplifier:							
11 A	10	330 + 470	340 + 480	350 + 480	360 + 480	100 + 130	110 + 130
<p>Note:</p> <p>Maximum output from the calibrator's terminals is 2.2 A. Uncertainty specifications for 220 mA and 2.2 mA ranges are increased by a factor of 1.3 when supplied through 5725A terminals.</p> <p>Specifications are otherwise identical for all output locations.</p> <ol style="list-style-type: none"> Add to uncertainty specifications: <ul style="list-style-type: none"> ±200 x I² ppm for >100 mA on 220 mA range ±10 x I² ppm for >1 A on 2.2 A range For fields strengths >0.4 V/m but ≤3 V/m, add 1 % of range. 							

5700A Series II DC Current Specifications

Range	Resolution	Absolute Uncertainty ±5 °C from calibration temperature ^[2]				Relative Uncertainty ±1 °C	
		24 Hours	90 Days	180 Days	1 Year	24 Hours	90 Days
		± (ppm output + nA)					
99 % Confidence Level							
220 µA	0.1	45 + 10	50 + 10	55 + 10	60 + 10	24 + 2	26 + 2
2.2 mA	1	45 + 10	50 + 10	55 + 10	60 + 10	24 + 5	26 + 5
22 mA	10	45 + 100	50 + 100	55 + 100	60 + 100	24 + 50	26 + 50
µA							
± (ppm output + µA)							
220 mA ^[1]	0.1	55 + 1	60 +	65 + 1	70 + 1	26 + 0.3	30 + 0.3
2.2 A ^[1]	1	75 + 30	80 + 30	90 + 30	95 + 30	40 + 7	45 + 7
5725A Amplifier:							
11 A	10	330 + 470	340 + 480	350 + 480	360 + 480	100 + 130	110 + 130
95 % Confidence Level							
nA							
± (ppm output + nA)							
220 µA	0.1	35 + 8	40 + 8	45 + 8	50 + 8	20 + 1.6	22 + 1.6
2.2 mA	1	35 + 8	40 + 8	45 + 8	50 + 8	20 + 4	22 + 4
22 mA	10	35 + 80	40 + 80	45 + 80	50 + 80	20 + 40	22 + 40
µA							
± (ppm output + µA)							
220 mA ^[1]	0.1	45 + 0.8	50 + 0.8	55 + 0.8	60 + 0.8	22 + 0.25	25 + 0.25
2.2 A ^[1]	1	60 + 25	65 + 25	75 + 25	80 + 25	35 + 6	40 + 6
5725A Amplifier:							
11 A	10	330 + 470	340 + 480	350 + 480	360 + 480	100 + 130	110 + 130
<p>Note:</p> <p>Maximum output from the calibrator's terminals is 2.2 A. Uncertainty specifications for 220 mA and 2.2 mA ranges are increased by a factor of 1.3 when supplied through 5725A terminals.</p> <p>Specifications are otherwise identical for all output locations.</p> <ol style="list-style-type: none"> Add to uncertainty specifications: <ul style="list-style-type: none"> ±200 x I² ppm for >100 mA on 220 mA range ±10 x I² ppm for >1 A on 2.2 A range For fields strengths >0.4 V/m but ≤3 V/m, add 1 % of range. 							

DC Current Secondary Performance Specifications and Operating Characteristics

Range	Stability ±1 °C ^[1] 24 Hours	Temperature Coefficient ^[2]		Compliance Limits	Burden Voltage Adder ^[3] (±nA/V)	Maximum Load for Full Accuracy ^[4] (Ω)	Noise	
		10 - 40 °C	0 - 10 °C and 40 - 50 °C				Bandwidth 0.1-10 Hz	Bandwidth 10 Hz-10 kHz
							pk-pk ppm output + nA	RMS nA
		± (ppm output + nA) / °C					ppm output + nA	nA
220 µA	5 + 1	1 + 0.40	3 + 1	10	0.2	20k	6 + .9	10
2.2 mA	5 + 5	1 + 2	3 + 10	10	0.2	2k	6 + 5	10
22 mA	5 + 50	1 + 20	3 + 100	10	10	200	6 + 50	50
220 mA	8 + 300	1 + 200	3 + 1 µA	10	100	20	9 + 300	500
2.2 A	9 + 7 µA	1 + 2.5 µA	3 + 10 µA	3 ^[5]	2 µA	2	12 + 1.5 µA	20 µA
5725A	± (ppm output + µA)	± (ppm output + µA) / °C					ppm output + µA	µA
11 A	25 + 100	20 + 75	30 + 120	4	0	4	15 + 70	175

Notes:

Maximum output from the calibrator's terminals is 2.2 A. Uncertainty specifications for 220 mA and 2.2 mA ranges are increased by a factor of 1.3 when supplied through 5725A terminals.

1. Stability specifications are included in the Absolute Uncertainty values for the primary specifications.
2. Temperature coefficient is an adder to uncertainty specifications. It does not apply unless operating more than ±5 °C from calibration temperature.
3. Burden voltage adder is an adder to uncertainty specifications that does not apply unless burden voltage is greater than 0.5 V.
4. For higher loads, multiply uncertainty specification by: $1 + \frac{0.1 \times \text{actual load}}{\text{maximum load for full accuracy}}$
5. The calibrator's compliance limit is 2 V for outputs from 1 A to 2.2 A. 5725A Amplifier may be used in range-lock mode down to 0 A.

Minimum Output:0 for all ranges, including 5725A.

Settling Time: 1 second for mA and mA ranges; 3 seconds for 2.2 A range; 6 seconds for 11 range; + 1 second for range or polarity change

Overshoot:<5 %

AC Current Specifications

5720A Series II AC Current Specifications: 99 % Confidence Level

Range	Resolution	Frequency (Hz)	Absolute Uncertainty ±5 °C from calibration temperature ^[1]				Relative Uncertainty ±1 °C	
			24 Hours	90 Days	180 Days	1 Year	24 Hours	90 Days
			± (ppm output + nA)					
220 µA	1 nA	10 - 20	260 + 20	280 + 20	290 + 20	300 + 20	260 + 20	280 + 20
		20 - 40	170 + 12	180 + 12	190 + 12	200 + 12	130 + 12	150 + 12
		40 - 1 k	120 + 10	130 + 10	135 + 10	140 + 10	100 + 10	110 + 10
		1k - 5 k	300 + 15	320 + 15	340 + 15	350 + 15	250 + 15	280 + 15
		5k - 10 k	1000 + 80	1100 + 80	1200 + 80	1300 + 80	900 + 80	1000 + 80
2.2 mA	10 nA	10 - 20	260 + 50	280 + 50	290 + 50	300 + 50	260 + 50	280 + 50
		20 - 40	170 + 40	180 + 40	190 + 40	200 + 40	130 + 40	150 + 40
		40 - 1 k	120 + 40	130 + 40	135 + 40	140 + 40	100 + 40	110 + 40
		1k - 5 k	210 + 130	220 + 130	230 + 130	240 + 130	250 + 130	280 + 130
		5k - 10 k	1000 + 800	1100 + 800	1200 + 800	1300 + 800	900 + 800	1000 + 800
22 mA	100 nA	10 - 20	260 + 500	280 + 500	290 + 500	300 + 500	260 + 500	280 + 500
		20 - 40	170 + 400	180 + 400	190 + 400	200 + 400	130 + 400	150 + 400
		40 - 1 k	120 + 400	130 + 400	135 + 400	140 + 400	100 + 400	110 + 400
		1k - 5 k	210 + 700	220 + 700	230 + 700	240 + 700	250 + 700	280 + 700
		5k - 10 k	1000 + 6000	1100 + 6000	1200 + 6000	1300 + 6000	900 + 6000	1000 + 6000
			± (ppm output + µA)					
220 mA	1 µA	10 - 20	260 + 5	280 + 5	290 + 5	300 + 5	260 + 5	280 + 5
		20 - 40	170 + 4	180 + 4	190 + 4	200 + 4	130 + 4	150 + 4
		40 - 1 k	120 + 3	130 + 3	135 + 3	140 + 3	100 + 3	110 + 3
		1k - 5 k	210 + 4	220 + 4	230 + 4	240 + 4	250 + 4	280 + 4
		5k - 10 k	1000 + 12	1100 + 12	1200 + 12	1300 + 12	900 + 12	1000 + 12
2.2 A	10 µA	20 - 1 k	290 + 40	300 + 40	310 + 40	320 + 40	300 + 40	350 + 40
		1 k - 5 k	440 + 100	460 + 100	480 + 100	500 + 100	500 + 100	520 + 100
		5 k - 10 k	6000 + 200	7000 + 200	7500 + 200	8000 + 200	6000 + 200	7000 + 200
5725A Amplifier:								
11 A	100 µA	40 - 1 k	370 + 170	400 + 170	440 + 170	460 + 170	300 + 170	330 + 170
		1 k - 5 k	800 + 380	850 + 380	900 + 380	950 + 380	700 + 380	800 + 380
		5 k - 10 k	3000 + 750	3300 + 750	3500 + 750	3600 + 750	2800 + 750	3200 + 750
<p>Note:</p> <p>Maximum output from the calibrator's terminals is 2.2 A. Uncertainty specifications for 220 µA and 2.2 mA ranges are increased by a factor of 1.3 plus 2 µA when supplied through 5725A terminals. For the 5720A 220 µA range, 1 kHz through 5 kHz and 5 kHz through 10 kHz, when the output is coming from the AUX current terminal, use the 5700A Absolute Uncertainty Specifications. Specifications are otherwise identical for all output locations.</p> <p>1. For fields strengths >0.4 V/m but ≤3 V/m, add 1 % of range.</p>								

5720A Series II AC Current Specifications: 95% Confidence Level

Range	Resolution	Frequency (Hz)	Absolute Uncertainty ±5 °C from calibration temperature ⁽¹⁾				Relative Uncertainty ±1 °C	
			24 Hours	90 Days	180 Days	1 Year	24 Hours	90 Days
			± (ppm output + nA)					
220 µA	1 nA	10 - 20	210 + 16	230 + 16	240 + 16	250 + 16	210 + 16	230 + 16
		20 - 40	130 + 10	140 + 10	150 + 10	160 + 10	110 + 10	130 + 10
		40 - 1 k	100 + 8	110 + 8	115 + 8	120 + 8	80 + 8	90 + 8
		1k - 5 k	240 + 12	250 + 12	270 + 12	280 + 12	200 + 12	230 + 12
		5k - 10 k	800 + 65	900 + 65	1000 + 65	1100 + 65	700 + 65	800 + 65
2.2 mA	10 nA	10 - 20	210 + 40	230 + 40	240 + 40	250 + 40	210 + 40	230 + 40
		20 - 40	140 + 35	140 + 35	150 + 35	160 + 35	110 + 35	130 + 35
		40 - 1 k	100 + 35	110 + 35	115 + 35	120 + 35	80 + 35	90 + 35
		1k - 5 k	170 + 110	180 + 110	190 + 110	200 + 110	200 + 110	230 + 110
		5k - 10 k	800 + 650	900 + 650	1000 + 650	1100 + 650	700 + 650	800 + 650
22 mA	100 nA	10 - 20	210 + 400	230 + 400	240 + 400	250 + 400	210 + 400	230 + 400
		20 - 40	130 + 350	140 + 350	150 + 350	160 + 350	110 + 350	130 + 350
		40 - 1 k	100 + 350	110 + 350	115 + 350	120 + 350	80 + 350	90 + 350
		1k - 5 k	170 + 550	180 + 550	190 + 550	200 + 550	200 + 550	230 + 550
		5k - 10 k	800 + 5000	900 + 5000	1000 + 5000	1100 + 5000	700 + 5000	800 + 5000
± (ppm output + µA)								
220 mA	1 µA	10 - 20	210 + 4	230 + 4	240 + 4	250 + 4	210 + 4	230 + 4
		20 - 40	130 + 3.5	140 + 3.5	150 + 3.5	160 + 3.5	110 + 3.5	130 + 3.5
		40 - 1 k	100 + 2.5	110 + 2.5	115 + 2.5	120 + 2.5	80 + 2.5	90 + 2.5
		1k - 5 k	170 + 3.5	180 + 3.5	190 + 3.5	200 + 3.5	200 + 3.5	230 + 3.5
		5k - 10 k	800 + 10	900 + 10	1000 + 10	1100 + 10	700 + 10	800 + 10
2.2 A	10 µA	20 - 1 k	230 + 35	240 + 35	250 + 35	260 + 35	250 + 35	300 + 35
		1 k - 5 k	350 + 80	390 + 80	420 + 80	450 + 80	400 + 80	440 + 80
		5 k - 10 k	5000 + 160	6000 + 160	6500 + 160	7000 + 160	5000 + 160	6000 + 160
5725A Amplifier:								
11 A	100 µA	40 - 1 k	370 + 170	400 + 170	440 + 170	460 + 170	300 + 170	330 + 170
		1 k - 5 k	800 + 380	850 + 380	900 + 380	950 + 380	700 + 380	800 + 38
		5 k - 10 k	3000 + 750	3300 + 750	3500 + 750	3600 + 750	2800 + 750	3200 + 750
<p>Note:</p> <p>Maximum output from the calibrator's terminals is 2.2 A. Uncertainty specifications for 220 µA and 2.2 mA ranges are increased by 1.3 plus 2 µA when supplied through 5725A terminals. For the 5720A 220 µA range, 1 kHz through 5 kHz and 5 kHz through 10 kHz, when the output is coming from the AUX current terminal, use the 5700A Absolute Uncertainty Specifications. Specifications are otherwise identical for all output locations.</p> <p>1. For fields strengths >0.4 V/m but ≤3 V/m, add 1 % of range.</p>								

5700A Series II AC Current Specifications: 99 % Confidence Level

Range	Resolution	Frequency (Hz)	Absolute Uncertainty ±5 °C from calibration temperature. ⁽¹⁾				Relative Uncertainty ±1 °C	
			24 Hours	90 Days	180 Days	1 Year	24 Hours	90 Days
			± (ppm output + nA)					
220 µA	1 nA	10 - 20	650 + 30	700 + 30	750 + 30	800 + 30	450 + 30	500 + 30
		20 - 40	350 + 25	380 + 25	410 + 25	420 + 25	270 + 25	300 + 25
		40 - 1 k	120 + 20	140 + 20	150 + 20	160 + 20	110 + 20	120 + 20
		1k - 5 k	500 + 50	600 + 50	650 + 50	700 + 50	450 + 50	500 + 50
		5k - 10 k	1500 + 100	1600 + 100	1700 + 100	1800 + 100	1400 + 100	1500 + 100
2.2 mA	10 nA	10 - 20	650 + 50	700 + 50	750 + 50	800 + 50	450 + 50	500 + 50
		20 - 40	350 + 40	380 + 40	410 + 40	420 + 40	270 + 40	300 + 40
		40 - 1 k	120 + 40	140 + 40	150 + 40	160 + 40	110 + 40	120 + 40
		1k - 5 k	500 + 500	600 + 500	650 + 500	700 + 500	450 + 500	500 + 500
		5k - 10 k	1500 + 1000	1600 + 1000	1700 + 1000	1800 + 1000	1400 + 1000	1500 + 1000
22 mA	100 nA	10 - 20	650 + 500	700 + 500	750 + 500	800 + 500	450 + 500	500 + 500
		20 - 40	350 + 400	380 + 400	410 + 400	420 + 400	270 + 400	300 + 400
		40 - 1 k	120 + 400	140 + 400	150 + 400	160 + 400	110 + 400	120 + 400
		1k - 5 k	500 + 5000	600 + 5000	650 + 5000	700 + 5000	450 + 5000	500 + 5000
		5k - 10 k	1500 + 10,000	1600 + 10,000	1700 + 10,000	1800 + 10,000	1400 + 10,000	1500 + 10,000
± (ppm output + µA)								
220 mA	1 µA	10 - 20	650 + 5	700 + 5	750 + 5	800 + 5	450 + 5	500 + 5
		20 - 40	350 + 4	380 + 4	410 + 4	420 + 4	280 + 4	300 + 4
		40 - 1 k	120 + 4	150 + 4	170 + 4	180 + 4	110 + 4	130 + 4
		1k - 5 k	500 + 50	600 + 50	650 + 50	700 + 50	450 + 50	500 + 50
		5k - 10 k	1500 + 100	1600 + 100	1700 + 100	1800 + 100	1400 + 100	1500 + 100
2.2 A	10 µA	20 - 1 k	600 + 40	650 + 40	700 + 40	750 + 40	600 + 40	650 + 40
		1 k - 5 k	700 + 100	750 + 100	800 + 100	850 + 100	650 + 100	750 + 100
		5 k - 10 k	8000 + 200	9000 + 200	9500 + 200	10,000 + 200	7500 + 200	8500 + 200
5725A Amplifier:								
11 A	100 µA	40 - 1 k	370 + 170	400 + 170	440 + 170	460 + 170	300 + 170	330 + 170
		1 k - 5 k	800 + 380	850 + 380	900 + 380	950 + 380	700 + 380	800 + 380
		5 k - 10 k	3000 + 750	3300 + 750	3500 + 750	3600 + 750	2800 + 750	3200 + 750
<p>Note:</p> <p>Maximum output from the calibrator's terminals is 2.2 A. Uncertainty specifications for 220 µA and 2.2 mA ranges are increased by a factor of 1.3 plus 2 µA when supplied through 5725A terminals. Specifications are otherwise identical for all output locations.</p> <p>1. For fields strengths >0.4 V/m but ≤3 V/m, add 1 % of range.</p>								

5700A Series II AC Current Specifications: 95 % Confidence Level

Range	Resolution	Frequency (Hz)	Absolute Uncertainty ±5 °C from calibration temperature ⁽¹⁾				Relative Uncertainty ±1 °C	
			24 Hours	90 Days	180 Days	1 Year	24 Hours	90 Days
			± (ppm output + nA)					
220 µA	1 nA	10 - 20	550 + 25	600 + 25	650 + 25	700 + 25	375 + 25	400 + 25
		20 - 40	280 + 20	310 + 20	330 + 20	350 + 20	220 + 20	250 + 20
		40 - 1 k	100 + 16	120 + 16	130 + 16	140 + 16	90 + 16	100 + 16
		1k - 5 k	400 + 40	500 + 40	550 + 40	600 + 40	375 + 40	400 + 40
		5k - 10 k	1300 + 80	1400 + 80	1500 + 80	1600 + 80	1200 + 80	1200 + 80
2.2 mA	10 nA	10 - 20	550 + 40	600 + 40	650 + 40	700 + 40	375 + 40	400 + 40
		20 - 40	280 + 35	310 + 35	330 + 35	350 + 35	220 + 35	250 + 35
		40 - 1 k	100 + 35	120 + 35	130 + 35	140 + 35	090 + 35	100 + 35
		1k - 5 k	400 + 400	500 + 400	550 + 400	600 + 400	375 + 400	400 + 400
		5k - 10 k	1300 + 800	1400 + 800	1500 + 800	1600 + 800	1200 + 800	1200 + 800
22 mA	100 nA	10 - 20	550 + 400	600 + 400	650 + 400	700 + 400	375 + 400	400 + 400
		20 - 40	280 + 350	310 + 350	330 + 350	350 + 350	220 + 350	250 + 350
		40 - 1 k	100 + 350	120 + 350	130 + 350	140 + 350	090 + 350	100 + 350
		1k - 5 k	400 + 4000	500 + 4000	550 + 4000	600 + 4000	375 + 4000	400 + 4000
		5k - 10 k	1300 + 8000	1400 + 8000	1500 + 8000	1600 + 8000	1200 + 8000	1200 + 8000
			± (ppm output + µA)					
220 mA	1 µA	10 - 20	550 + 4	600 + 4	650 + 4	700 + 4	375 + 4	400 + 4
		20 - 40	280 + 3.5	310 + 3.5	330 + 3.5	350 + 3.5	220 + 3.5	250 + 3.5
		40 - 1 k	100 + 3.5	120 + 3.5	130 + 3.5	140 + 3.5	90 + 3.5	100 + 3.5
		1k - 5 k	400 + 40	500 + 40	550 + 40	600 + 40	375 + 40	400 + 40
		5k - 10 k	1300 + 80	1400 + 80	1500 + 80	1600 + 80	1200 + 80	1200 + 80
2.2 A	10 µA	20 - 1 k	500 + 35	550 + 35	600 + 35	650 + 35	500 + 35	550 + 35
		1 k - 5 k	600 + 80	650 + 80	700 + 80	750 + 80	550 + 80	650 + 80
		5 k - 10 k	6500 + 160	7500 + 160	8000 + 1600	8500 + 160	6000 + 160	7000 + 160
5725A Amplifier:								
11 A	100 µA	40 - 1 k	370 + 170	400 + 170	440 + 170	460 + 170	300 + 170	330 + 170
		1 k - 5 k	800 + 380	850 + 380	900 + 380	950 + 380	700 + 380	800 + 380
		5 k - 10 k	3000 + 750	3300 + 750	3500 + 750	3600 + 750	2800 + 750	3200 + 750

Note:
Maximum output from the calibrator's terminals is 2.2 A. Uncertainty specifications for 220 A and 2.2 mA ranges are increased by a factor of 1.3 plus 2 µA when supplied through 5725A terminals. Specifications are otherwise identical for all output locations.

1. For fields strengths >0.4 V/m but ≤3 V/m, add 1 % of range.

AC Current Secondary Performance Specifications and Operating Characteristics

Range	Frequency (Hz)	Stability ±1 °C [1] 24 Hours	Temperature Coefficient [2]		Compliance Limits (V rms)	Maximum Resistive Load For Full Accuracy [3] (Ω)	Noise and Distortion (Bandwidth 10 Hz - 50 kHz <0.5V Burden)
			10 - 40 °C	0 - 10 °C and 40 - 50 °C			
			± (ppm output + nA)/°C				
220 μA	10 - 20	150 + 5	50 + 5	50 + 5	7	2 k [6]	0.05 + 0.1
	20 - 40	80 + 5	20 + 5	20 + 5			0.05 + 0.1
	40 - 1 k	30 + 3	4 + 0.5	10 + 0.5			0.05 + 0.1
	1 k - 5 k	50 + 20	10 + 1	20 + 1			0.25 + 0.5
	5 k - 10 k	400 + 100	20 + 100	20 + 100			00.5 + 1
2.2 mA	10 - 20	150 + 5	50 + 5	50 + 5	7	500	0.05 + 0.1
	20 - 40	80 + 5	20 + 4	20 + 4			0.05 + 0.1
	40 - 1 k	30 + 3	4 + 1	10 + 2			0.05 + 0.1
	1 k - 5 k	50 + 20	10 + 100	20 + 100			0.25 + 0.5
	5 k - 10 k	400 + 100	50 + 400	50 + 400			00.5 + 1
22 mA	10 - 20	150 + 50	50 + 10	50 + 10	7	150	0.05 + 0.1
	20 - 40	80 + 50	20 + 10	20 + 10			0.05 + 0.1
	40 - 1 k	30 + 30	4 + 10	10 + 20			0.05 + 0.1
	1 k - 5 k	50 + 500	10 + 500	20 + 400			0.25 + 0.5
	5 k - 10 k	400 + 1000	50 + 1000	50 + 1000			00.5 + 1
	Hz	± (ppm output + μA)	± (ppm output + μA) / °C				
220 mA	10 - 20	150 + 0.5	50 + 0.05	50 + 0.05	7	15	0.05 + 10
	20 - 40	80 + 0.5	20 + 0.05	20 + 0.05			0.05 + 10
	40 - 1 k	30 + 0.3	4 + 0.1	10 + 0.1			0.05 + 10
	1 k - 5 k	50 + 3	10 + 2	20 + 2			0.25 + 50
	5 k - 10 k	400 + 5	50 + 5	50 + 5			00.5 + 100
2.2 A	20 - 1 k	50 + 5	4 + 1	10 + 1	1.4 [4]	0.5	0.5 + 100
	1 k - 5 k	80 + 20	10 + 5	20 + 5			0.3 + 500
	5 k - 10 k	800 + 50	50 + 10	50 + 10			0.1 + 1 mA
5725A Amplifier:							± (% output)
11 A	40 - 1 k	75 + 100	20 + 75	30 + 75	3	3	0.05 [5]
	1 k - 5 k	100 + 150	40 + 75	50 + 75			0.12 [5]
	5 k - 10 k	200 + 300	100 + 75	100 + 75			0.5 [5]

Notes:

Maximum output from 5720A terminals is 2.2 A. Uncertainty specifications for 220 μA and 2.2 mA ranges are increased by a factor of 1.3, plus 2 μA when supplied through 5725A terminals. Specifications are otherwise identical for all output locations.

- Stability specifications are included in the Absolute Uncertainty values for the primary specifications.
- Temperature coefficient is an adder to uncertainty specifications that does not apply unless operating more than ±5 °C from calibration temperature.
- For larger resistive loads multiply uncertainty specifications by: $(\frac{\text{actual load}}{\text{maximum load for full accuracy}})^2$
- 1.5 V compliance limit above 1 A. 5725A Amplifier may be used in range-lock mode down to 1 A.
- For resistive loads within rated compliance voltage limits.
- For outputs from the Aux Current terminals, the maximum resistive load for full accuracy is 1 kΩ. For larger resistive loads, multiply the uncertainty as described in Note 3.

Minimum Output9 μA for 220 μA range, 10 % on all other ranges. 1 A minimum for 5725A.

Inductive Load Limits400 μH (5700A/5720A, or 5725A). 20 μH for 5700A/5720A output >1 A.

Power Factors5700A/5720A, 0.9 to 1; 5725A, 0.1 to 1. Subject to compliance voltage limits.

Frequency:

Range (Hz)10.000 - 11.999, 12.00 - 119.99, 120.0 - 1199.9, 1.200 k - 10.000 k

Uncertainty.....±0.01 %

Resolution11,999 counts

Settling Time5 seconds for 5700A/5720A ranges; 6 seconds for 5725A 11 A range; +1 second for amplitude or frequency range change.

Overshoot.....<10 %

Wideband AC Voltage (Option 5700-03) Specifications

Wideband AC Voltage (Option 5700-03) Specifications

Specifications apply to the end of the cable and 50 Ω termination used for calibration.

Range		Resolution	Absolute Uncertainty ±5 °C from calibration temperature 30 Hz - 500 kHz			
			24 Hours	90 Days	180 Days	1 Year
Volts	dBm		± (% output + μV)			
1.1 mV	-46	10 nV	0.4 + 0.4	0.5 + 0.4	0.6 + 0.4	0.8 + 2
3 mV	-37	10 nV	0.4 + 1	0.45 + 1	0.5 + 1	0.7 + 3
11 mV	-26	100 nV	0.2 + 4	0.35 + 4	0.5 + 4	0.7 + 8
33 mV	-17	100 nV	0.2 + 10	0.3 + 10	0.45 + 10	0.6 + 16
110 mV	-6.2	1 μV	0.2 + 40	0.3 + 40	0.45 + 40	0.6 + 40
330 mV	+3.4	1 μV	0.2 + 100	0.25 + 100	0.35 + 100	0.5 + 100
1.1 V	+14	10 μV	0.2 + 400	0.25 + 400	0.35 + 400	0.5 + 400
3.5 V	+24	10 μV	0.15 + 500	0.2 + 500	0.3 + 500	0.4 + 500

Frequency (Hz)	Frequency Resolution (Hz)	Amplitude Flatness, 1 kHz Reference Voltage Range			Temperature Coefficient ±ppm/°C	Settling Time To Full Accuracy (Seconds)	Harmonic Distortion (dB)
		1.1 mV	3 mV	>3 mV			
± (% output + floor indicated)							
10 - 30	0.01	0.3	0.3	0.3	100	7	-40
30 - 120	0.01	0.1	0.1	0.1	100	7	-40
120 - 1.2 k	0.1	0.1	0.1	0.1	100	5	-40
1.2 k - 12 k	1	0.1	0.1	0.1	100	5	-40
12 k - 120 k	10	0.1	0.1	0.1	100	5	-40
120 k - 1.2 M	100	0.2 + 3 μV	0.1 + 3 μV	0.1 + 3 μV	100	5	-40
1.2 M - 2 M	100 k	0.2 + 3 μV	0.1 + 3 μV	0.1 + 3 μV	100	0.5	-40
2 M - 10 M	100 k	0.4 + 3 μV	0.3 + 3 μV	0.2 + 3 μV	100	0.5	-40
10 M - 20 M	1 M	0.6 + 3 μV	0.5 + 3 μV	0.4 + 3 μV	150	0.5	-34
20 M - 30 M	1 M	1.5 + 15 μV	1.5 + 3 μV	1 + 3 μV	300	0.5	-34

Additional Operating Information:

dBm reference = 50 Ω

Range boundaries are at voltage points, dBm levels are approximate.

$$\text{dBm} = 10 \log \left(\frac{\text{Power}}{1\text{mW}} \right); 0.22361 \text{ V across } 50 \Omega = 1 \text{ mW or } 0 \text{ dBm}$$

Minimum Output.....300 μV (-57 dBm)

Frequency Uncertainty.....±0.01 %

Frequency Resolution 11,999 counts to 1.1999 MHz, 119 counts to 30 MHz

Overload Protection.....A short circuit on the wideband output will not result in damage. After settling time, normal operation is restored upon removal.

Auxiliary Amplifier Specifications

For complete specifications, see the 5205A and 5220A Operators Manuals.

5205A (220V - 1100 V ac, 0 V - 1100 V dc)

Overshoot: < 10 %

Distortion (bandwidth 10 Hz - 1 MHz):

10 Hz - 20 kHz0.07 %

20 kHz - 50 kHz0.2 %

50 kHz - 100 kHz0.25 %

Frequency (Hz)	90 Day Accuracy at 23 ±5 °C ± (% output + % range)	Temperature Coefficient for 0 - 18 °C and 28 - 50 °C ± (ppm output + ppm range) / °C
0 dc	0.05 + 0.005	15 + 3
10 - 40	0.15 + 0.005	45 + 3
40 - 20 k	0.04 + 0.004	15 + 3
20 k - 50 k	0.08 + 0.006	50 + 10
50 k - 100 k	0.1 + 0.01	70 + 20

5220A (AC Current, 180-day specifications):

Accuracy:

20 Hz - 1 kHz0.07 % + 1 mA

1 kHz - 5 kHz(0.07 % + 1 mA) x frequency in kHz

Temperature Coefficient (0 - 18 °C and 28 - 50 °C):

(0.003 % + 100A) / °C

Distortion (bandwidth 300 kHz):

20 Hz - 1 kHz0.1% + 1 mA

1 kHz - 5 kHz(0.1% + 1 mA) x frequency in kHz

Note: 5700A/5720A combined with 5220A is not specified for inductive loads.

Ordering Information

Model

5720A	Calibrator
5700A	Series II Calibrator
5725A	Amplifier

Options

5700A-03	Wideband AC Voltage (compatible with both the 5700A and the 5720A)
----------	--

Accessories

5440A-7002	Low-Thermal Test Leads, banana plugs
5440A-7003	Low-Thermal Test Leads, spread lugs
Y5735	Rack Mount Kit for 5725A
Y5737	Rack Mount Kit for 5700A and 5720A

Related Models

732B	DC Standard
734A	DC Reference Standard
742A	Standard Resistors
752A	Reference Divider
792A	AC/DC Transfer Standard
5790A	AC Measurement Standard

Software

MET/CAL® Plus	Automated Calibration Management Software Upgrade
5700A/EP	Upgrade your 5700A Series I Calibrator to 5720A Specifications



Fluke. Keeping your world
up and running.

Fluke Corporation
PO Box 9090, Everett, WA USA 98206

Fluke Europe B.V.
PO Box 1186, 5602 BD
Eindhoven, The Netherlands

For more information call:
In the U.S.A. (800) 443-5853 or
Fax (425) 446-5116
In Europe/M-East/Africa (31 40) 2 675 200 or
Fax (31 40) 2 675 222
In Canada (800)-36-FLUKE or
Fax (905) 890-6866
From other countries +1 (425) 446-5500 or
Fax +1 (425) 446-5116
Web access: <http://www.fluke.com/>

©2005 Fluke Corporation. All rights reserved.
Specifications subject to change without notice.
Printed in U.S.A. 1/2005 1268275 D-ENG-N Rev D