1 General Information

The Cable Sets

The Agilent 85133E/F/H flexible cable sets are designed for use with Agilent network analyzers that have male NMD-2.4 mm test ports.

85133E

The 85133E set contains a single cable. Use it when a DUT is connected, with the appropriate adapter, directly to the test set test port. See [Figure 1-1](#).

85133F

The 85133F set contains two cables. Each is shorter than the 85133E cable. Use the 85133F cables when a DUT is connected between cable ends. See [Figure 1-1](#).

Figure 1-1 Cable Configurations

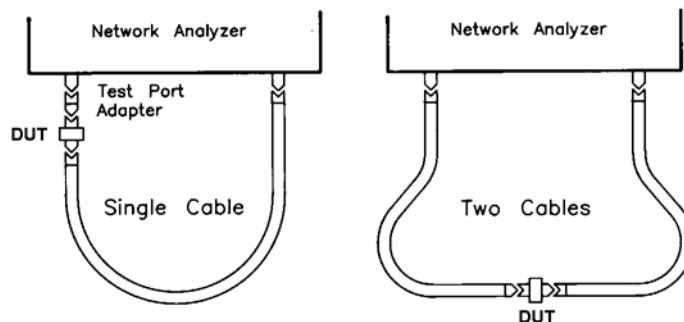

85133H

The 85133H set contains a single cable – the -f- to -m- cable from the 85133F cable set. It is shorter than the 85133E single cable. See [Figure 1-1](#).

Connector Designators

NMD Connectors

NMD denotes a connector that has larger than standard coupling threads for greater stability. NMD connectors are used on test cables, test ports, test port adapters, and test port cables.

Female slotted NMD test port connectors are used on the test set end of adapters and cables, and *cannot* be connected to standard male connectors.

Male NMD connectors are used on test sets (as test ports), and on the DUT end of adapters and cables. Male connectors have both the larger threads (for use with test port adapters) and standard threads (for direct coupling to a DUT).

PSC Connectors

PSC denotes a precision slotless connector. Precision slotless connectors are metrology grade connectors that have better electrical performance, better repeatability, and are more durable than slotted connectors.

Clarifying the Terminology of a Connector Interface

In this document and in the prompts of the PNA calibration wizard, the gender of cable connectors and adapters is referred to in terms of the center conductor. For example, a connector or device designated as 1.85 mm –f– has a 1.85 mm female center conductor.

8510-series, 872x, and 875x ONLY: In contrast, during a measurement calibration, the network analyzer softkey menus label a 1.85 mm calibration device with reference to the sex of the analyzer’s test port connector—not the calibration device connector. For example, the label SHORT(F) refers to the short that is to be connected to the female test port. This will be a male short from the calibration kit.

Table 1-1 Clarifying the Sex of Connectors: Examples

Terminology	Meaning
Short –f–	Female short (female center conductor)
Short (f)	Male short (male center conductor) to be connected to female port

A connector gage is referred to in terms of the connector that it measures. For instance, a male connector gage has a female connector on the gage so that it can measure male devices.

Incoming Inspection

Verify that the shipment is complete by referring to [Table 4-1 on page 4-4](#).

If the case or any device appears damaged, or if the shipment is incomplete, notify Agilent. See [“Contacting Agilent” on page 4-3](#). Agilent will arrange for repair or replacement of incomplete or damaged shipments without waiting for a settlement from the transportation company.

When you send the cable set to Agilent, include the following information:

- your company name and address
- the name of a technical contact person within your company, and the person’s complete phone number
- the model number and serial number of the cable set

- the part number and serial number of the device
- the type of service required
- a *detailed* description of the problem

Preventive Maintenance

The best techniques for maintaining the integrity of the cables include:

- routine visual inspection
- cleaning
- proper gaging
- proper connection techniques
- proper storage

All of the above are described in [Chapter 3](#). Failure to detect and remove dirt or metallic particles on a mating plane surface can degrade repeatability and accuracy and can damage any connector mated to it. Improper connections, resulting from center conductor values being out of limits (see [Table 2 on page 2-4](#)), or from bad connections, can also damage cable connectors.

Replaceable Parts

See [Table 4-1 on page 4-4](#) for a complete list of cable set contents and their associated part numbers (you can order a single cable rather than the entire cable set), and for recommended items not included with the cable set. Refer to [“Contacting Agilent” on page 4-3](#) for information about communicating with Agilent.

2 Specifications

Environmental Requirements

Table 2-1 Environmental Requirements

Parameter	Limits
Operating temperature	+20 °C to +26 °C (+68 °F to +79 °F)
Storage temperature	-40 °C to +75 °C (-40 °F to +167 °F)
Altitude	
Operation	< 4,500 meters (≈15,000 feet)
Storage	< 4,500 meters (≈15,000 feet)
Relative humidity	Always non-condensing
Operation	Up to 80% at 30°C
Storage	Up to 95% at 40°C

Electrical Specifications

Table 2-2 Electrical Specifications

Cable	SWR	Return Loss (dB)	Insertion Loss (dB) ^a	Frequency Range (GHz)
85133E	≤1.44	≥15	≤0.1 + 0.57√f + 0.02f	DC to 50
85133F			≤0.1 + 0.38√f + 0.017f	
85133H				

a. f = frequency in GHz.

Supplemental Characteristics

Table 2-3 lists supplemental performance characteristics. These are not specifications, but are intended to provide additional information useful to your application. Supplemental characteristics are typical (but not warranted) performance parameters.

Table 2-3 Supplemental Characteristics (1 of 3)

Cable	Cable Length		Approximate Electrical Length		Magnitude and Phase Stability With a 90° Bend ^{a,b}	Random Use Magnitude and Phase Stability ^{a,c}	Minimum Recommended Bend Radius	
	cm	in	m	ft			cm	in
85133E	97.2	38.25	1.125	3.690	<0.15 dB Change <0.17° (f) + 0.5°	<0.07 dB Change <0.09° (f) + 0.5°	6.352	2.5
85133F	62.9	24.75	0.7376	2.418	<0.08 dB Change <0.08° (f) + 0.5°	<0.04 dB Change <0.04° (f) + 0.5°		
85133H								

- a. (f) = frequency in GHz.
- b. With a 90°, 2.5-inch bend radius.
- c. After three 90°, 2.5-inch bend radius/straighten cycles.

Table 2-3 Supplemental Characteristics (2 of 3)

Cable Set	Number of Cables	Test Set End Connector Type	DUT End Connector Type
85133E	1	NMD-2.4 mm -f- Slotted	PSC-2.4 mm -f- Slotless
85133F	2	NMD-2.4 mm -f- Slotted	NMD-2.4 mm -m- and PSC-2.4 mm -f- Slotless
85133H	1	NMD-2.4 mm -f- Slotted	NMD-2.4 mm -m-

Center Conductor Pin Depth

Center conductor pin depth is the distance the center conductor mating plane differs from being flush with the outer conductor mating plane. See Figure 2-1 The pin depth of a center conductor can be in one of two states: either protruding or recessed.

Protrusion is the condition in which the center conductor extends beyond the outer conductor mating plane. This condition will indicate a positive value on the connector gage.

Recession is the condition in which the center conductor is set back from the outer conductor mating plane. This condition will indicate a negative value on the connector gage.

Figure 2-1 Connector Center-Conductor Pin Depth

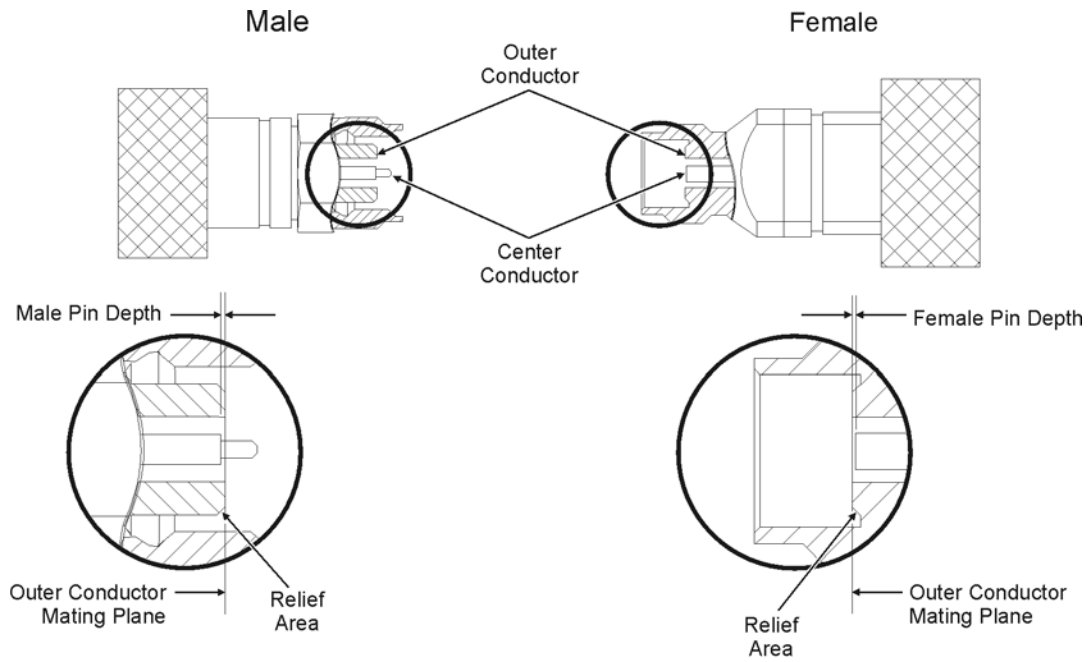

conn185_new

Table 2-3 Supplemental Characteristics (3 of 3)

Precision Connector	Center-Conductor Pin Depth			
	Allowable Recession ^a		Allowable Protrusion	
	mm	in	mm	in
NMD-2.4 mm -f-	-0.000 to -0.056	-0.0000 to -0.0022	0.0000	0.0000
NMD-2.4 mm -m-	-0.0025 to -0.0254	-0.0001 to -0.001		
PSC-2.4 mm -f-	-0.0025 to -0.0254	-0.0001 to -0.001		

a. Center conductor shoulder behind outer conductor mating plane.