

MODEL 92EA RF MILLIVOLTMETER INSTRUCTION MANUAL

BOONTON

BOONTON ELECTRONICS ■ 25 EASTMANS ROAD ■ PARSIPPANY, NEW JERSEY 07054-0465

TELEPHONE: (973) 386-9696 ■ FAX: (973) 386-9191 ■ E-MAIL: boonton@boonton.com

MANUAL P/N 98201600D
DATE 11/95

SAFETY SUMMARY

The following general safety precautions must be observed during all phases of operation and maintenance of this instrument. Failure to comply with these precautions or with specific warnings elsewhere in this manual violates safety standards of design, manufacture, and intended use of the instruments. Boonton Electronics assumes no liability for the customer's failure to comply with these requirements.

THE INSTRUMENT MUST BE GROUNDED.

To minimize shock hazard the instrument chassis and cabinet must be connected to an electrical ground. The instrument is equipped with a three conductor, three prong AC power cable. The power cable must either be plugged into an approved three-contact electrical outlet or used with a three-contact to a two-contact adapter with the (green) grounding wire firmly connected to an electrical ground at the power outlet.

DO NOT OPERATE THE INSTRUMENT IN AN EXPLOSIVE ATMOSPHERE.

Do not operate the instrument in the presence of flammable gases or fumes.

KEEP AWAY FROM LIVE CIRCUITS.

Operating personnel must not remove instrument covers. Component replacement and internal adjustments must be made by qualified maintenance personnel. Do not replace components with the power cable connected. Under certain conditions dangerous voltages may exist even though the power cable was removed; therefore, always disconnect power and discharge circuits before touching them.

DO NOT SERVICE OR ADJUST ALONE.

Do not attempt internal service or adjustment unless another person, capable of rendering first aid and resuscitation, is present.

DO NOT SUBSTITUTE PARTS OR MODIFY INSTRUMENT.

Do not install substitute parts or perform any unauthorized modification of the instrument. Return the instrument to Boonton Electronics for repair to ensure that the safety features are maintained.

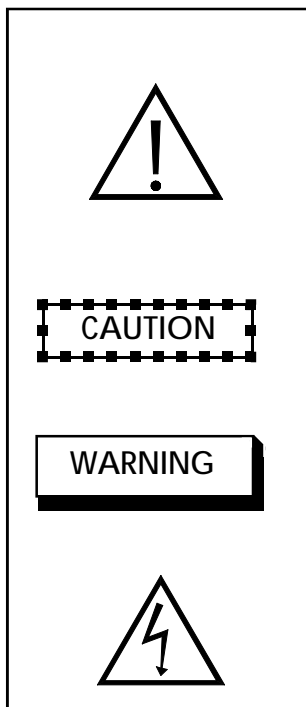

This safety requirement symbol has been adopted by the International Electrotechnical Commission, Document 66 (Central Office) 3, Paragraph 5.3, which directs that an instrument be so labeled if, for the correct use of the instrument, it is necessary to refer to the instruction manual. In this case it is recommended that reference be made to the instruction manual when connecting the instrument to the proper power source. Verify that the correct fuse is installed for the power available, and that the switch on the rear panel is set to the applicable operating voltage.

The CAUTION sign denotes a hazard. It calls attention to an operation procedure, practice, or the like, which, if not correctly performed or adhered to, could result in damage to or destruction of part or all of the equipment. Do not proceed beyond a CAUTION sign until the indicated conditions are fully understood and met.

The WARNING sign denotes a hazard. It calls attention to an operation procedure, practice, or the like, which, if not correctly performed or adhered to, could result in injury or loss of life. Do not proceed beyond a warning sign until the indicated conditions are fully understood and met.

This SAFETY REQUIREMENT symbol has been adopted by the International Electrotechnical Commission, document 66 (Central Office)3, Paragraph 5.3 which indicates hazardous voltage may be present in the vicinity of the marking.

IMPORTANT NOTICE

AUGUST 25, 1993

INSTRUCTION MANUAL-ADDENDUM: MODEL 92EA

Instruction manual addenda are issued to adapt the manual to changes and improvements made after its printing. Please review the following text and retain with your manual for future reference. These changes will be applied in the next printing of the manual.

Thank you for selecting Boonton Electronics for your Test and Measurement needs.

TABLE 1-1. SPECIFICATIONS page 1-3

AI. Basic Uncertainty, Voltage Ranges:

Change 200 μ V - 3000 mV, 1% fs.

to:

Voltage Level	mV
1.0 mV - 3000 mV	1 % rdg. + 1 % fs
0.2 mV - 1 mV	2 % rdg. + 1 % fs

BI. Frequency Effect

Change the SWR specification in the table pertaining to the 952002 50 ohm BNC adapter from:

SWR: 1.05 to 300 MHz, 1.10 to 1 GHz, 1.15 to 1.2 GHz.

to:

SWR: 1.05 to 300 MHz, 1.15 to 1.2 GHz.

REPLACEABLE PARTS LIST page 6-5.

Change CD4030AE part number 534087000

to:

CD4030BE part number 53444722A.

TABLE OF CONTENTS

PARAGRAPH		PAGE
Section I General Information		
1-1	Introduction.....	1-1
1-2	Description.....	1-1
1-4	Accessories.....	1-1
1-7	Options.....	1-2
1-9	Specifications.....	1-2
Section II Installation		
2-1	Introduction.....	2-1
2-3	Unpacking.....	2-1
2-5	Mounting.....	2-1
2-7	Power Requirements.....	2-1
2-10	Cable Connections.....	2-1
2-11	Preliminary Checkout Procedure.....	2-1
Section III Operation		
3-1	Introduction.....	3-1
3-3	Operating Controls, Indicators and Connectors.....	3-1
3-5	Operating Instructions.....	3-1
3-7	Initial Conditions.....	3-1
3-8	Measurements.....	3-1
3-10	Measurement Considerations.....	3-1
3-11	Interface Operation.....	3-2
3-13	Input Characteristics.....	3-2
Section IV Theory of Operation		
4-1	Introduction.....	4-1
4-3	Functional Block Diagram Description.....	4-1
4-7	Detailed Circuit Descriptions.....	4-2
4-9	Sensor (RF Probe).....	4-2
4-13	Chopper Circuits.....	4-3
4-14	Amplifier Circuits.....	4-3
4-16	Demodulator Circuits.....	4-3
4-17	Driver Circuits.....	4-4
4-18	Clock Circuits.....	4-4
4-19	Ranging and Programming Circuits.....	4-4
4-21	Shaping Circuits.....	4-5
4-32	Power Supply Circuits.....	4-6
Section V Maintenance		
5-1	Introduction.....	5-1
5-3	Safety Requirements.....	5-1
5-5	Test Equipment Required.....	5-1
5-7	Cleaning Procedure.....	5-1
5-9	Removal and Replacement Procedures.....	5-1
5-10	Instrument Covers.....	5-1
5-11	RF Probe Replacement.....	5-1
5-12	Inspection Procedure.....	5-1
5-14	Performance Tests.....	5-1
5-15	Power Supply Tests.....	5-1
5-16	Instrument Calibration Tests.....	5-2

PARAGRAPH

PAGE

Section V Maintenance (continued)

5-17	Probe Tests.....	5-2
5-18	Probe SWR Test.....	5-2
5-20	Probe Frequency Response Test.....	5-3
5-22	Swept Frequency Response and SWR Test.....	5-4
5-24	Adjustments.....	5-6
5-25	Chopper Adjustments.....	5-6
5-26	Delay Adjustment.....	5-6
5-27	Zeroing Adjustment.....	5-6
5-28	Master Gain Adjustments.....	5-6
5-29	Output Integrator Adjustments.....	5-7
5-30	Range Adjustments.....	5-7
5-31	Troubleshooting.....	5-7
5-36	Trouble Localization.....	5-7

Section VI Parts List

6-1	Introduction.....	6-1
-----	-------------------	-----

Section VII Schematic Diagrams

7-1	Table of Contents.....	7-1
-----	------------------------	-----

List of Illustrations

1-1	Model 92EA RF Millivoltmeter.....	iv
1-2	Outline Dimensions.....	1-5
2-1	Packing and Unpacking Diagram.....	2-2
3-1	Model 92EA Front View.....	3-3
3-2	Model 92EA Rear View.....	3-3
3-3	Correction Curves for Type N Tee Adapters Models 952003-01A (50 Ohm) and 952007-01A (75 Ohm).....	3-6
3-4	Correction Curve for BNC Adapter 952002 (50 Ohm).....	3-6
3-5	Rear Panel Pin Assignments.....	3-7
4-1	Functional Block Diagram.....	4-1
4-2	Amplifier Circuits Block Diagram.....	4-2
4-3	Demodulator and Driver Circuits Block Diagram.....	4-3
4-4	Ranging Circuits Block Diagram.....	4-4
4-5	Shaping Circuits Block Diagram.....	4-5
4-6	Power Supply Circuits Block Diagram.....	4-6
5-1	Frequency Response Test Setup.....	5-3
5-2	Swept Frequency Response Test Setup.....	5-4
5-3	Adjustment Locations and Descriptions.....	5-5

List of Tables

1-1	Specifications.....	1-2
3-1	Operating Controls, Indicators and Connectors.....	3-4
3-2	Measurements.....	3-5
3-3	Rear Panel Pins: Unit Loadings and Comments.....	3-7
3-4	Interface Input Characteristics.....	3-7
5-1	Maintenance Test Equipment.....	5-2
5-2	Power Supply Tests Points.....	5-2
5-3	Troubleshooting Chart.....	5-8
6-1	Manufacturer's Federal Supply Code Numbers.....	6-1
6-2	List of Replaceable Parts.....	6-1



Figure 1-1. Model 92EA RF Millivoltmeter

SECTION I

GENERAL INFORMATION

1-1. INTRODUCTION

This instruction manual provides general information, installation, operation, theory of operation, maintenance instructions, parts list, and schematics for the Model 92EA RF Millivoltmeter.

1-2. DESCRIPTION

The Model 92EA is a solid state, sensitive, accurate, and sturdily constructed RF Millivoltmeter that is characterized by high input impedance, excellent stability, and low noise.

1-3. The 92EA design features are as follows:

a. **Frequency Range.** Provides voltage measurements over the frequency range of 10 kHz to 1.2 GHz and 10 Hz to 100 MHz with the -16 Option. Relative accuracy above 1.2 GHz is typically ± 0.5 dB. Relative accuracy refers to the differential between two measured levels without regard to the absolute accuracy of either measurement. A measurement of a 100 mV signal at 8 GHz may indicate 20 mV on the meter; then a 50 mV signal, at that same frequency, will be indicated as 10 mV, within about 0.5 dB (5.9%).

b. **Voltage Range.** The voltage range is 200 μ V to 3 V (300 V with the 100:1 divider accessory). The voltmeter has eight ranges, from 1 mV, fs, to 3V, fs, arranged in a 1-3-10 sequence. The instrument exhibits true RMS response for input signals up to 30 millivolts gradually approaching peak-to-peak above this level. The meter, however, is calibrated to indicate RMS of a sinewave above 30 mV.

c. **Low Noise.** The instrument is designed and constructed to hold noise from all sources to a minimum. The probe cable is of special low-noise design; a vigorous flexing causes only momentary, minor deflections of the meter on the most sensitive range. The probe itself is insensitive to shock or to vibration.

Amplification takes place at 94 Hz, reducing susceptibility to any 50 or 60 Hz line-frequency-related fields. The input signals from the probe are converted into 94 Hz signals by a solid-state chopper.

d. **Minimal Zero Adjustment.** Zero adjustment is not required on the upper five sensitivity ranges of the voltmeter.

For measurements on the lower three ranges, the ZERO control is adjusted on the most sensitive range before operation. Only infrequent checking will be required during the course of subsequent measurements.

e. **DC Output.** The instrument provides a linear DC output whose current capability of 1 mA into 1000 ohms is extremely stable. When used as part of an automatic test system, the fast response of the instrument's DC output to an input step-function allows many tests per unit time.

1-4. ACCESSORIES

1-5. The following accessories are supplied with the instrument:

a. **952001B-2 RF Probe.** Probe with low-noise cable and connector assembly for measurements from 10 kHz to 1.2 GHz.

b. **952002 50 ohm BNC Adapter.** Used for measurements up to 1.2 GHz in a 50 ohm system.

c. **952004 Probe Tip.** Removable probe tip with grounding-clip lead; for use up to approximately 100 MHz.

1-6. The following accessories are optional and may be ordered:

a. **91-6F Underterminated Type F Adapter (F).**

b. **91-6G Underterminated BNC Adapter (M).**

c. **91-8B/1A 75 ohm Type F Adapter (F).**

d. **91-14A 50 ohm Tee Adapter N (F/F).** Permits connection into 50 ohm line; operational to 1.2 GHz.

e. **91-15A 50 ohm Termination N (M).**

f. **91-16A Underterminated N Adapter (F).** May be used with all probes. Used for coaxial connection up to approximately 100 MHz, or to 400 MHz when fed from a 50 ohm source in an electrically short system.

- g. 950000 Rack Mtg. Kit, Single. Mounts one unit left or right of blank panel in 19 inch rack. 5.25 inches high.
- h. 950001 Rack Mtg. Kit, Dual. Mounts two units side by side in 19 inch rack. 5.25 inches high.
- i. 950002 Single Rack-Mounting Kit. Kit for mounting one 92EA as one-half of a module in a standard 19 inch rack.
- j. 950031 Transit Case.
- k. 952003 50 ohm Tee Adapter. Type-N (F/F) Tee connector used with 91-15A termination, it permits connection into a 50 ohm line.
- l. 952005 100:1 Voltage Divider. Attenuates input signal by a factor of $100 + \frac{f}{200}$ %, permitting measurements up to 300 V, and extending the rms measuring range to 3V; also increases input resistance by a factor of 1000 to 3000, depending upon input level. Operates from 50 kHz to 700 MHz. Maximum input potential, 1000 V, DC plus peak AC.
- m. 952006 75 ohm BNC Adapter (F). Used for measurements up to 500 MHz in a 75 ohm system.
- n. 952007 75 ohm Tee Adapter. Type-N (F) Tee connector; used with 91-15A/1 termination it permits connection into a 75 ohm line.
- o. 952008 Unterminated BNC Adapter. Used for coaxial connection up to approximately 100 MHz, or to 400 MHz when fed from a 50 ohm source in an electrically short system.
- p. 952011-1 Accessory Kit, 50 Ohms. Kit contains the following items: 952008, unterminated BNC adapter (F); 952005, 100:1 voltage divider; 952003, 50 ohm Tee adapter; 91-15A, 50 ohm termination N(M); Model 952013, Storage Case (case for protecting and storing kit accessories).
- q. 952012-1 Accessory Kit, 75 ohm. Contains the following items; 952008, unterminated BNC adapter; 952005, 100:1 divider; 952007, 75 ohm Tee adapter; 91-15A/1, type-N 75 ohm termination; and 952013 storage case.
- r. 952013 Accessory Case. For use with the model 952001 probe and accessories.
- s. 952016-1 Low Frequency Probe. 10 Hz to 100 MHz. Overload protection, 10 VAC and 50 VDC.
- t. 952058 100:1 Divider. For use with 952016 Low Frequency Probe; frequency range 10 Hz to 20 MHz.

1-7. OPTIONS

1-8. The following options are available:

- a. -04 dBV Scale Uppermost. The dBV scale is uppermost on the meter face. The two voltage scales are above and below the mirror.
- b. -06 75 Ohm dBm Scale Uppermost. The dBm scale is uppermost on the meter face. The 952006 75 Ohm BNC adapter is supplied instead of the standard 952002 50 ohm BNC adapter.
- c. -08 Rear Signal Input. An additional RF probe input connector is located on the rear panel.
- d. -12 dBmV Scale Uppermost. The dBV scale is uppermost on the meter face. The 952006 75 ohm BNC adapter is supplied instead of the standard 952002 50 ohm BNC adapter.
- e. -16 Low Frequency Version. Frequency Range 10 Hz to 100 MHz, utilizes the 952016-1 probe.

1-9. SPECIFICATIONS

1-10. Specifications are listed in Table 1-1.

TABLE 1-1. SPECIFICATIONS

Voltage Range: 200 μ V to 3V (300 V up to 700 MHz with accessory 100:1 voltage divider). Lowest detectable voltage is approximately 100 μ V.

Full-Scale Voltage Ranges: 1, 3, 10, 30, 100, 300, 1000, and 3000 mV.

dBm Range: -61 to +23 dBm (with the 50 ohm adapters. -63 to +21 dBm (with the 75 ohm adapters).

Frequency Range: 10 kHz to 1.2 GHz (uncalibrated response to approximately 8 GHz).

Accuracy: The maximum uncertainty is the sum of the uncertainties given in sections A, B, and C.

A1. Basic Uncertainty, Voltage Ranges:

Voltage Level	mV
1.0 mV - 3000 mV	1% rdg + 1%fs
0.2mV - 1mV	2%rdg + 1%fs

A2. Basic Uncertainty, dBm:

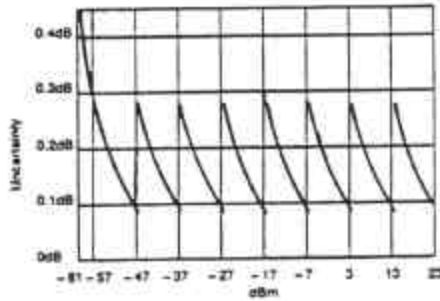

B1. Frequency Effect: (952001B Probe)

50 ohm measurements using the 952001B Probe with the 952002 BNC Adapter or terminated 952003 Type-N Tee Adapter at 100 mV level.

Frequency	mV	dBm
1 MHz (cal freq)	0	0
100 kHz - 100 MHz	1% rdg	0.09 dB
100 MHz - 1 GHz	3% rdg	0.27 dB
1 GHz - 1.2 GHz	7% rdg	0.63 dB

SWR: 1.05 to 300 MHz; 1.15 to 1.2 GHz.

B2. Frequency Effect: (952016 Probe)
-16 Option:

50 ohm measurements using the 952016 Probe with the 952002 BNC Adapter.

Frequency	mV	dBm
1 MHz (cal freq)	0	0
50 Hz - 20 MHz	1% rdg	0.09 dB
20 Hz - 50 Hz	2% rdg	0.17 dB
10 Hz - 100 MHz	5% rdg	0.44 dB

SWR: 1.05 to 100 MHz.

B3. Frequency Effect: (952016 Probe)
with 952058 100:1 Divider:

Frequency	mV	dBm
1 MHz (cal freq)	0	0
1 MHz - 20 MHz	5% rdg	0.44 dB
50 Hz - 1 MHz	3.5% rdg	0.31 dB
20 Hz - 50 Hz	4.5% rdg	0.40 dB
10 Hz - 20 Hz	7.5% rdg	0.68 dB

SWR: 1.05 to 100 MHz.

C. Temperature Effect, at 1 MHz:
With 952001B Probe

Temperature Range	mV Ranges	
	Instrument	RF Probe
21° C to 25° C	0	0
18° C to 30° C	0.2% rdg	1% rdg
10° C to 40° C	0.5% rdg	3% rdg
0° C to 55° C	1% rdg	7% rdg

Temperature Range	mV Ranges	
	Instrument	RF Probe
21° C to 25° C	0	0
18° C to 30° C	0.02 rdg	0.09 dB
10° C to 40° C	0.04 rdg	0.26 dB
0° C to 55° C	0.09 rdg	0.63 dB

Maximum AC input: 10 V, all frequencies and ranges.

Maximum DC input: 200 V, all ranges.

Meter: 4.5 inch taut-band.

Two linear voltage scales:
0 to 3; resolution 0.05/division.
0 to 10; resolution 0.1/division.

One, logarithmic dBm scale:
-10 to +3; resolution 0.2/division, max

Meter Unrest: (1 mV fs range, only).

Indicated Voltage	Unrest
Above 600 uV	< 1% fs
300 uV to 600 uV	< 2% fs
200 uV to 300 uV	< 5% fs

EMI: There is no significant radiated or conducted leakage from the instrument or the probe.

Waveform Response: True RMS response for input levels up to 30 mV (3 volts to 700 MHz using the 100:1 Voltage Divider), with transition to peak-to-peak (calibrated in RMS) at higher levels.

Crest Factor:

Direct Input:	Level CF	300uV 140	1mV 42	3mV 14	10mV 4.2	30mV 1.4
With Divider:	Level CF	30mV 140	100mV 42	300mV 14	1V 4.2	3V 1.4

SWR: Less than 1.15 to 1.2 GHz (return loss greater than 23 dB).

DC Output: 0 to 10 VDC, proportional to RF input voltage. Source resistance of 9K ohm; will deliver 1 mA into 1K ohm load. Full-scale input step function response time less than 100 ms on 30 mV, fs, to 3 V, fs, ranges, increasing to 1 s on the 1 mV, fs, range.

Power: 100, 120, 200, 240 V \pm 10%, 50 to 400 Hz.

Ventilation Requirements:

1 1/2" clearance after installation, top side and rear.

Temperature:

Operating: 0 to +55°C

Non-operating: -40 to +75°C

Altitude:

Operating: 10,000 ft.

Non-operating 15,000 ft.

Humidity: 95% (non-condensing)

Dimensions: 5.83 in (14.9 cm) high x 8.34 in (21.1 cm) wide and 13.17 in (33.3 cm) deep. Refer to Figure 1-2 Outline Dimensions.

Weight: Net 3.2 kg (7 lbs.)

CE Mark: Declares Conformity to European Community (EC) Council Directives: 89/336/EEC/193/68/EEC, 73/23/EEC/193/68/EEC & Standards: EN55011, EN50082-1, EN61010-1.

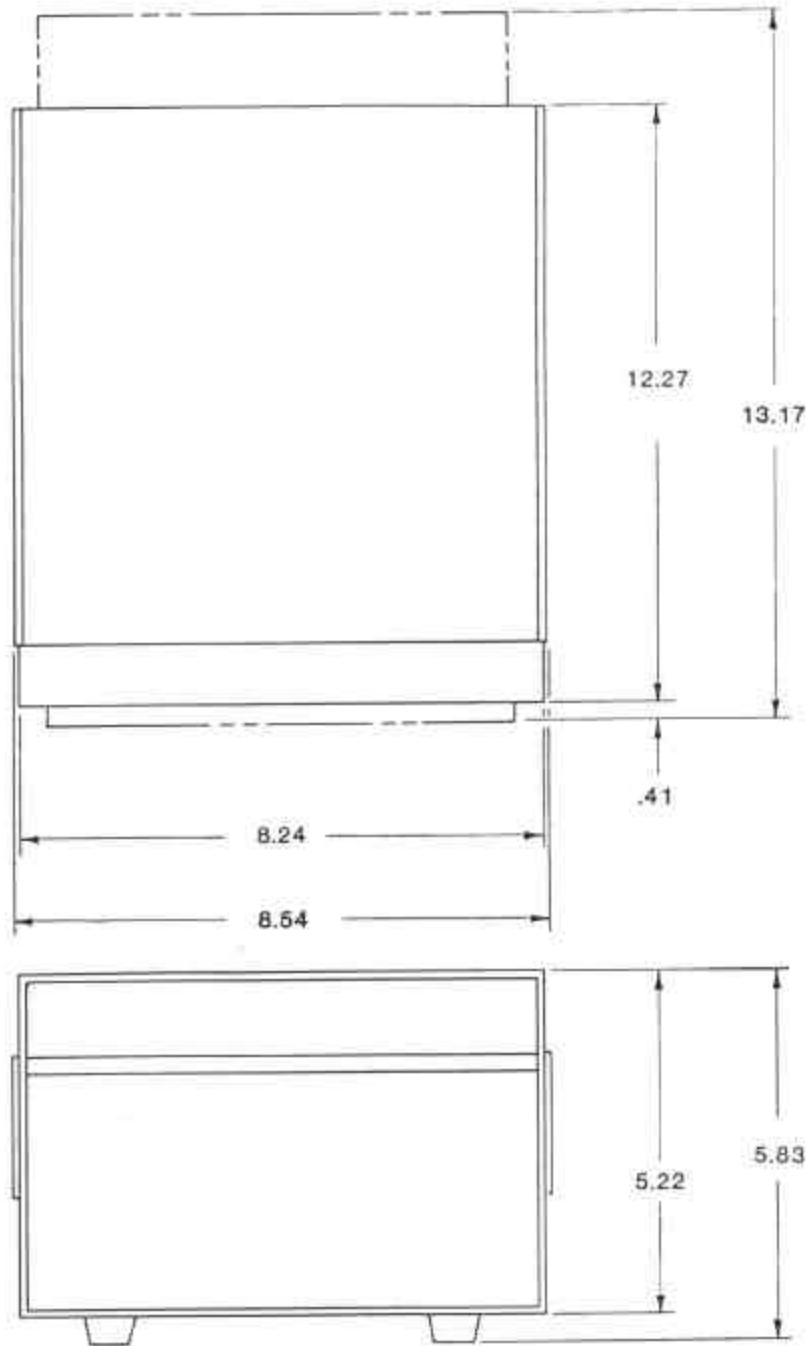

33012307A REVA

Figure 1-2. Outline Dimensions.

SECTION II

INSTALLATION

2-1. INTRODUCTION

2-2. This section contains the unpacking, mounting, power requirements, line voltage selection, cable connections and the preliminary checkout procedure.

2-3. UNPACKING

2-4. The instrument is shipped complete and is ready to use upon receipt. Unpack the instrument from its shipping container and inspect it for damage that may have occurred during shipment. Refer to Figure 2-1.

NOTE

Save the packing material and container for possible use in reshipment of the instrument.

2-5. MOUNTING

2-6. For bench mounting, choose a clean, sturdy, uncluttered mounting surface. For rack mounting an accessory kit is available.

2-7. POWER REQUIREMENTS

2-8. The instrument has a tapped power transformer and two line voltage selection switches which permit operation from 100, 120, 220 and 240 volt $\pm 10\%$, 50 to 60 Hz, single phase AC power sources. Power consumption is approximately 5 VA.

CAUTION

Always make certain that the line voltage selector switches are set to the correct positions most nearly corresponding to the voltage of the available AC power source, and that a fuse of the correct rating is installed in the fuse holder before connecting the instrument to any AC power source.

2-9. Set the line voltage selector switches, located on the rear panel to the appropriate positions as indicated on the LINE VOLTAGE SELECT chart located next to the switches. Check that the line fuse is correct for the selected power source.

VOLTAGE	FUSE
100/120 V	0.2 A MDL (SB)
220/240 V	0.1 A MDL (SB)

2-10. CABLE CONNECTIONS

2-11. Cable connections required depend on the use of the instrument. Cable connections that may be required are as follows:

a. Connect the probe cable to the front panel PROBE jack or if Option -08 is installed connect the probe cable to the rear panel PROBE jack.

b. An ANALOG OUTPUT connector is located on the rear panel which provides a connection to monitor a DC voltage proportional to the meter reading.

c. A REMOTE connector is located on the rear panel which provides a connection for operation with a remote interface.

2-12. PRELIMINARY CHECKOUT PROCEDURE

a. Make sure that the serial number of the probe to be used is listed on the accessory label on the rear panel. (Each instrument is calibrated for its particular RF probe.) Use of a probe other than that for which the instrument was calibrated may result in measurement errors.

b. Connect the probe cable to the PROBE jack on the front panel.

c. Connect the power cord to the instrument and the desired power source. Refer to paragraph 2-7 for proper power application.

d. Set the LINE ON/OFF power switch to ON.

e. Press the 1 mV range pushbutton; the panel meter pointer should rest on zero. If it does not, use the ZERO control to set the meter to zero. (This adjustment will hold for the other ranges.) The instrument is now ready for use.

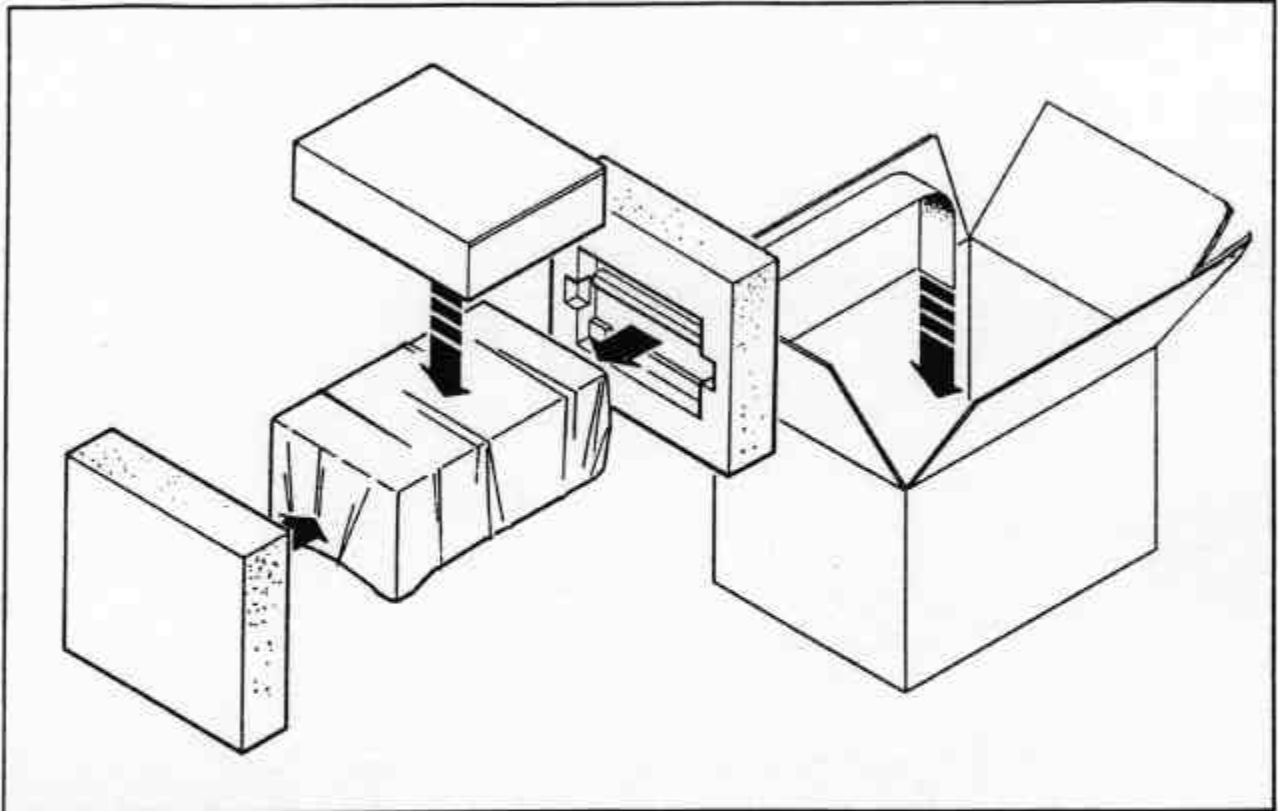

Figure 2-1. Packing and Unpacking Diagram.

SECTION III

OPERATION

3-1. INTRODUCTION

3-2. This section contains the operating controls, indicators, and connectors descriptions and functions, and operating instructions for the Model 92EA.

3-3. OPERATING CONTROLS, INDICATORS AND CONNECTORS

3-4. The controls, indicators, and connectors used during operation of the instrument are listed in Table 3-1 and shown in Figures 3-1 and 3-2.

3-5. OPERATING INSTRUCTIONS

3-6. The operating instructions for the Model 92EA are as follows:

- a. Initial Conditions.
- b. Measurements.
- c. Interface Operation.

3-7. INITIAL CONDITIONS

- a. Make sure that the serial number of the probe to be used is listed on Accessory label on rear panel. Each instrument is calibrated for its particular RF probe. Use of a probe other than that for which the instrument was calibrated may result in measurement errors.
- b. Connect the probe cable to the PROBE jack on the front panel.
- c. Connect the power cord to the instrument and the desired power source. Refer to paragraph 2-7 for proper power application.
- d. Set the LINE ON/OFF power switch to ON.
- e. Press the 1 mV range pushbutton; the panel meter pointer should rest on zero. If it does not, use the ZERO control to set the meter to zero. (This adjustment will hold for the other ranges.)

f. Press the range pushbutton that is closest to the level of the measurement to be made. The instrument is now ready for use.

3-8. MEASUREMENTS

3-9. The instrument is capable of making different types of measurements: Refer to Table 3-2 for Measurement and Connection Requirements.

3-10. MEASUREMENT CONSIDERATIONS

a. Temperature Effects. Over the range of 21° C to 25° C (70° F to 77° F), temperature effects for the instrument and the Model 952001B RF Probe are sensibly zero. Outside of these limits, inaccuracies can be expected as described in the Specifications section. However, no permanent change in probe characteristics will result from exposure to any reasonable high or low temperature.

Inaccuracies of measurement resulting from temperature effects may occur shortly after soldering close to the probe tip, or when measurements are made close to heat sources such as resistors, heat sinks, vacuum tubes, etc.

When making low level measurements (below approximately 2 millivolts) it is important to make sure that the probe has attained a uniform temperature throughout its body. A temperature gradient between the inside and the outside of the probe can generate a small thermal voltage that may add to the DC output of the detector diodes.

b. Hum, Noise and Spurious Pick-up. When measuring low level signals, precautions should always be taken to avoid the possibility of errors of measurement resulting from hum, noise or stray RF pick-up. Although all low frequency hum and noise are attenuated at the input, it is still possible for unwanted high level signals to cause errors. In some cases it may be necessary to provide extra shielding around the probe connections to reduce stray pickup. Typical sources of spurious radiation are: induction or dielectric heating units, diathermy machines, local radio transmitters, and grid dip meters.

c. Signal Overload on 1 mV Range. On the most sensitive (1 mV) range, the application of a large AC signal overloads the amplifier and a short time is required for the high im-

pedance input circuit to discharge. This effect is significant for signals above approximately 100 millivolts. Typically, application of a 1 volt signal will require a recovery time of about thirty seconds before subsequent measurements should be made on the 1 mV range.

d. Correction Curve for Model 952002. Refer to Figure 3-4 and use the correction curve to account for adapter loss when using the 50 ohm BNC Adapter.

e. Correction Curves for Model 952003 and 952007. Refer to Figure 3-3 and use the correction curves to make corrections for transmission loss when using the Type N 50 ohm or 75 ohm Tee Adapters.

3-11. INTERFACE OPERATION

3-12. Remote programming is accomplished by simultaneously shorting to common the Manual Disable and the appropriate range lines on the card edge connector located at the rear of the instrument. (In effect, when Manual Disable is brought to common, the front panel switches are disconnected). Refer to Figure 3-3 and Table 3-3 for a pictorial and tabular presentation of the rear panel programming inputs and data output connections.

(SEE TABLE 3-1)

3-13. INPUT CHARACTERISTICS.

- a. Interface input characteristics are given in Table 3-4.
- b. Input Pull-Up. All input terminals have internal pull-up. The current sourced by this pull-up when the input is brought to a logic level 0 is included in the loading shown in the "Unit Loading" column of Table 3-4.
- c. DC Analog Output.
 1. Polarity: Positive with respect to instrument ground. (The negative DC analog output terminal is at ground potential).
 2. Source Resistance: 9K ohm.

NOTES

1. The Insertion Loss shown is that which exists between the input and output ports of the Tee.
2. The RF Millivoltmeter measures the input voltage of the Tee.

3. Therefore, if the output voltage of the Tee is to be determined, subtract the Insertion Loss determined from the graph from the value that is indicated on the instrument.

4. Do not use the correction if terminated measurements are required (i.e., measurements with Model 952028-01A or Model 952029-01A terminations installed on the output port of the Tee).

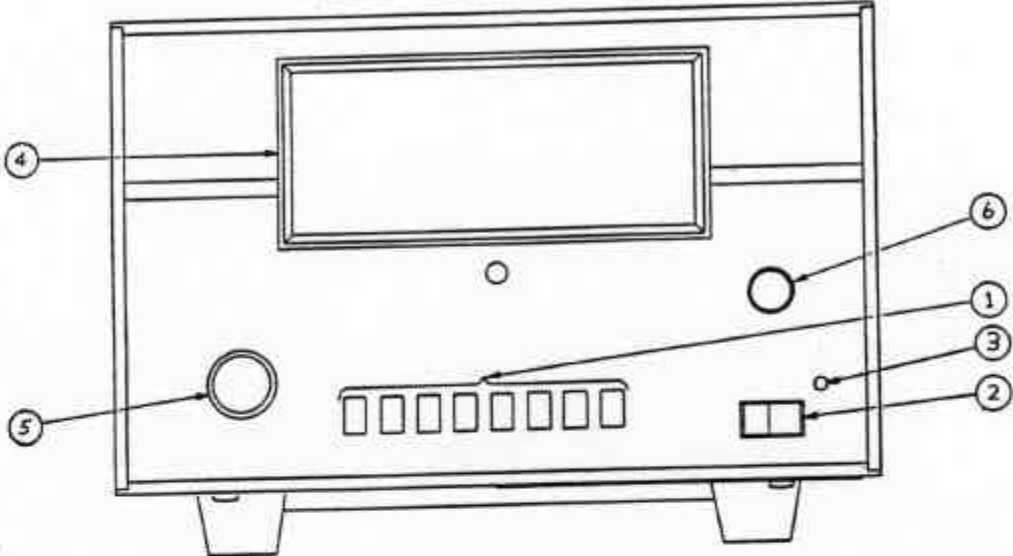

Figure 3-1. Model 92EA Front View

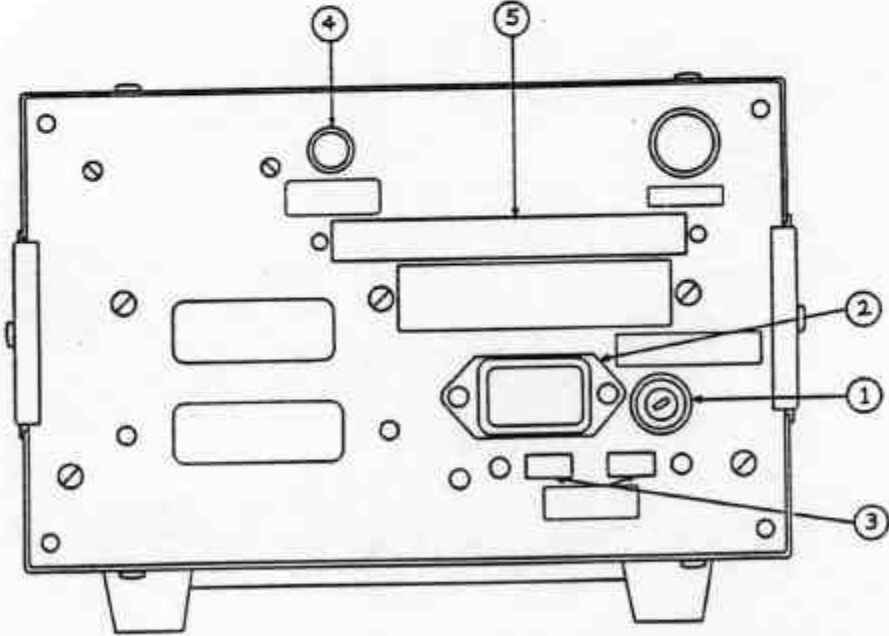

Figure 3-2. Model 92EA Rear View

TABLE 3-1. OPERATION CONTROLS, INDICATORS, AND CONNECTORS

Control, Indicator or Connector	Figure and Index Number	Function																		
FRONT PANEL																				
FULL SCALE Pushbuttons	3-1, 1	Depressing any full scale range push-button selects the operating range.																		
<table border="0"> <tr> <td>mV</td> <td>dBm</td> </tr> <tr> <td>3k</td> <td>+20</td> </tr> <tr> <td>1k</td> <td>+10</td> </tr> <tr> <td>300</td> <td>0</td> </tr> <tr> <td>100</td> <td>-10</td> </tr> <tr> <td>30</td> <td>-20</td> </tr> <tr> <td>10</td> <td>-30</td> </tr> <tr> <td>3</td> <td>-40</td> </tr> <tr> <td>1</td> <td>-50</td> </tr> </table>	mV	dBm	3k	+20	1k	+10	300	0	100	-10	30	-20	10	-30	3	-40	1	-50		
mV	dBm																			
3k	+20																			
1k	+10																			
300	0																			
100	-10																			
30	-20																			
10	-30																			
3	-40																			
1	-50																			
LINE ON/OFF SWITCH	3-1, 2	Turns the AC power On or OFF																		
LED Indicator	3-1, 3	Amber light emitting diode is lit when the instrument is turned ON.																		
METER	3-1, 4	Taut-band meter with two linear voltage scales and one logarithmic dBm scale.																		
PROBE Jack	3-1, 5	Provides a connection for the probe cable.																		
ZERO Control	3-1, 6	Zeros the instrument on the three most sensitive ranges.																		
REAR PANEL																				
Fuse Holder	3-2, 1	Fuse Holder. 0.2A, for 100/120 V; 0.1A for 220/240 V.																		
AC Connector	3-2, 2	AC power connector																		
Slide Switches	3-2, 3	Selects the proper operating voltage.																		
Analog Output	3-2, 4	A DC voltage proportional to the meter reading is available at these terminals.																		
Remote Connections	3-2, 5	The card edge plug is intended for use with an Amphenol 225-22221-101 connector, or equivalent. See Table 3-3 for pin designations.																		

TABLE 3-2. MEASUREMENTS

Measurement	Connection Requirements
Standard 92EA Frequency: 10 kHz - 1.2 GHz Voltage: 200 μ V - 3 V Impedance: 50 ohms	952001A RF Probe 952002 50 ohm BNC Adapter 952004 Probe Tip
Frequency: 10 kHz - 1.2 GHz Voltage: 3 V - 300 V Impedance: 50 ohms	952001 RF Probe 952002 50 ohm BNC Adapter 952004 Probe Tip 952005 100:1 Divider
In Line Measurements	952003 50 ohm Tee Adapter (N) (F/F) (Optional)
92EA-06 and 92EA-12 Options Frequency: 10 kHz - 1.2 GHz Voltage: 200 μ V - 3 V Impedance: 75 ohms	952001A RF Probe 952006 75 ohm BNC Adapter 952004 Probe Tip
Frequency: 10 kHz - 1.2 GHz Voltage: 3 V - 300 V Impedance: 75 ohms	952001 RF Probe 952006 75 ohm BNC Adapter 952004 Probe Tip 952005 100:1 Divider
In Line Measurements	952007 75 ohm Tee Adapter (N) (Optional)
92EA-16 Frequency: 10 Hz - 100 MHz Voltage: 200 μ V - 3 V Impedance: 50 ohms	952016-1 RF Probe 952002 50 ohm BNC Adapter 952004 Probe Tip
Frequency: 10 Hz - 100 MHz Voltage: 3 V - 300 V Impedance: 50 ohms	952016-1 RF Probe 952002 50 ohm BNC Adapter 952004 Probe Tip 952058 100:1 Divider
In Line Measurements	952003 50 ohm Tee Adapter (N) (F/F) (Optional)
CAUTION	
Overload Limits. The RF Probe supplied with the instrument is overload protected to 10 VAC, and 200 VDC. EXCEEDING THESE LIMITS MAY RESULT IN PERMANENT DAMAGE TO THE PROBE.	
The 952002 50 ohm adapter should not be subjected to continuous overload of more than 3 volts (DC+AC _{RMS}), to avoid excessive heating of the terminating resistor. When voltages above these limits could be encountered, the 100:1 Voltage Divider is required.	
WARNING	
To avoid possible shock hazard when making handheld measurements with the RF probe tip, the probe housing MUST be connected to a low-impedance ground using the grounding lead provided with the probe. It should never be left disconnected or attached to a return path that is floating or hot.	
NOTE	
When making measurements below 100 MHz, utilize the RF probe tip supplied with the instrument. When making measurements above 100 MHz, the probe tip should not be used. Connection should be made directly to the probe's center contact, with the ground connection kept as short as possible.	

CORRECTION FOR INSERTION LOSS

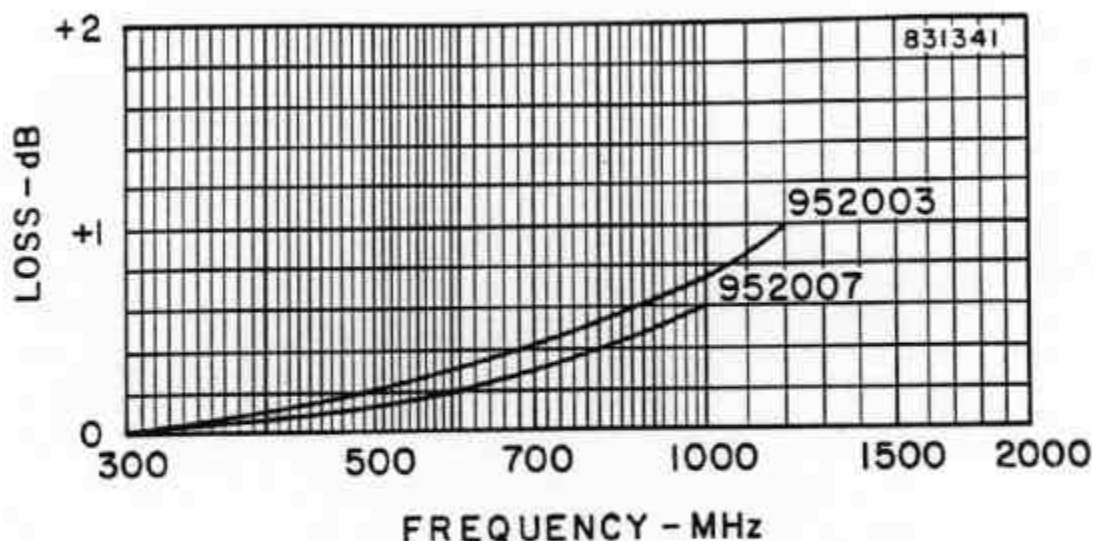

NOTES

- 1.) The Insertion Loss shown is that which exists between the input and output ports of the Tee.
- 2.) The RF Millivoltmeter measures the input voltage of the Tee.
- 3.) Therefore, if the output voltage of the Tee is to be determined, subtract the Insertion Loss determined from the graph from the value that is indicated on the instrument.
- 4.) Do not use the correction if terminated measurements are required (i.e., measurements with Model 952028-01A or Model 952029-01A terminations installed on the output port of the Tee).

**Figure 3-3. Correction Curves for Type N Tee Adapter
Models 952003-01A (50 ohm), and 952007-01A (75 ohm)**

CORRECTION FOR ADAPTER LOSS
FOR USE WITH RF PROBES:
952001, 952001A AND 952001B

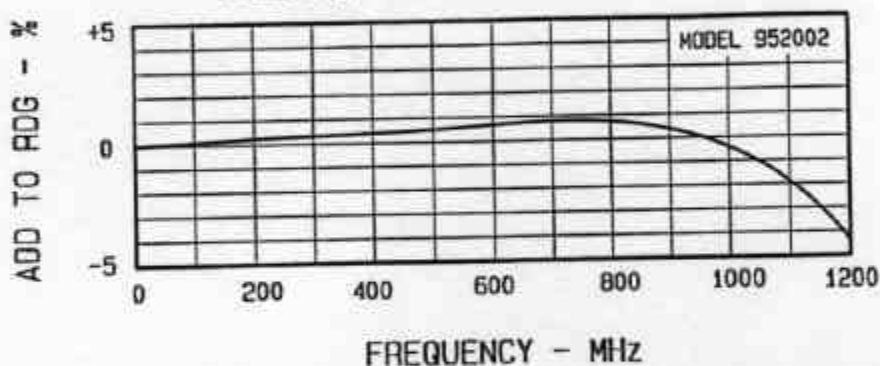

83158000A

Figure 3-4.

TABLE 3-3. REAR PANEL PINS: UNIT LOADINGS AND COMMENTS

Pin No.	Function	Comment	Command	Unit Loading
7	Man. Disable	Disables Front-Panel range selection	0	0.1
16	1 mV range	Selects range, provided that Manual Disable has also been selected. Selecting more than one range will result in incorrect indications. Range lines must be de-selected for manual operation.	0	0.1
15	3 mV range		0	0.1
14	10 mV range		0	0.1
13	30 mV range		0	0.1
12	100 mV range		0	0.1
11	300 mV range		0	0.1
10	1 V range		0	0.1
9	3 V range		0	0.1
5	Common	Power line ground at rear panel. +10 V for full scale of "1" ranges; +9.5 V for "3" ranges.	N/A	N/A
4	DC Analog		N/A	N/A

TABLE 3-4. INTERFACE INPUT CHARACTERISTICS

TTL Series	Logic Level	Voltage Level	Current Per Unit Load
Standard Power 54/74	0 1	+/- 0.7 V 2.4 to 5.25 V	+/- 1.6 mA* 40 uA

*The "-" current indicates current out of the input (the external command device must sink this current). A standard power (series 54/74) TTL output will sink and source 10 unit loads.

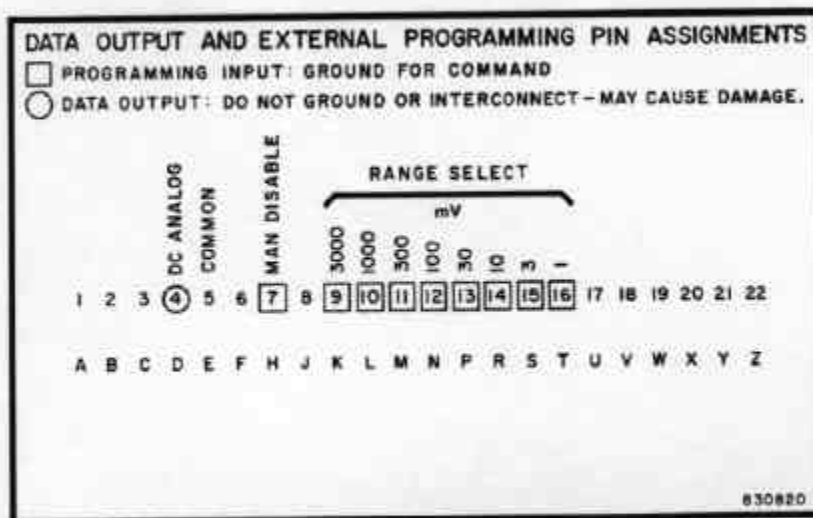

Figure 3-5. Rear Panel Pin Assignments

SECTION IV

THEORY OF OPERATION

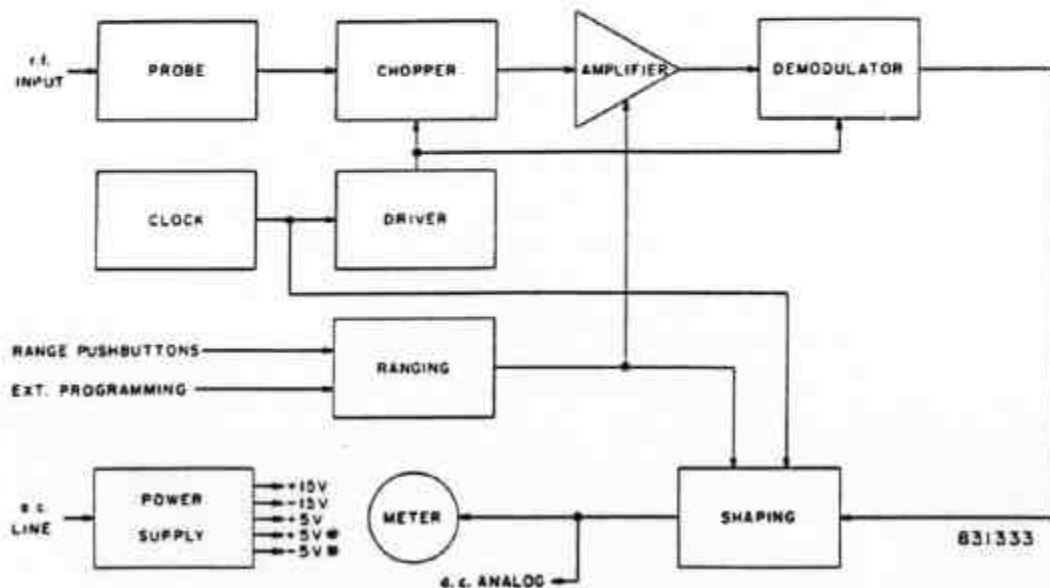

Figure 4-1. Functional Block Diagram

4-1. INTRODUCTION

4-2. The Model 92EA is a solid state, sensitive, accurate, and sturdily constructed RF Millivoltmeter that is characterized by high input impedance, excellent stability, and low noise.

4-3. FUNCTIONAL BLOCK DIAGRAM DESCRIPTION (Refer to Figure 4-1).

4-4. The RF voltage to be measured by the instrument is applied to a sensor, which converts the RF voltage to a proportional DC voltage. The output voltage from the sensor ranges from a fraction of a millivolt to volts, as a function of the input voltage level to the sensor. To reduce the effects of drift and residuals at very low levels, the DC output voltage of the sensor is applied to a solid state chopper, which converts the DC voltage to a 94 Hz square wave with an amplitude proportional to the DC voltage. The drive signals for the chopper are provided from the analog section.

4-5. The analog section provides amplification, ranging, and demodulation of the 94-Hz square-wave signal sup-

plied from the chopper. Ranging is performed manually by means of eight pushbuttons on the front panel; remote ranging is available by means of rear panel programming connectors. The analog section also receives a 752 Hz clock signal from the clock section; the chopper and demodulator drive signals are derived from this clock signal by frequency divider circuits in the analog section. The DC output voltage of the analog section is supplied to the shaping section, where the amplified and demodulated DC voltage is converted to a linear voltage used for driving the meter and the analog output. The probe's output is inherently non-linear before shaping; it is true RMS on the lower ranges, and peak-to-peak on the higher ranges.

4-6. Operating power for the instrument circuits is provided by the power supply. Line voltages of 100, 120, 220 or 240 volts, +/- 10%, may be applied to the power transformer. Switches on the rear panel of the instrument allow the switching of primary winding connections in order to accommodate the various input voltages. The secondary windings of the power transformer furnish power to rectifier regulator circuits that develop regulated +5, -5, +15, and -15 volts for opera-

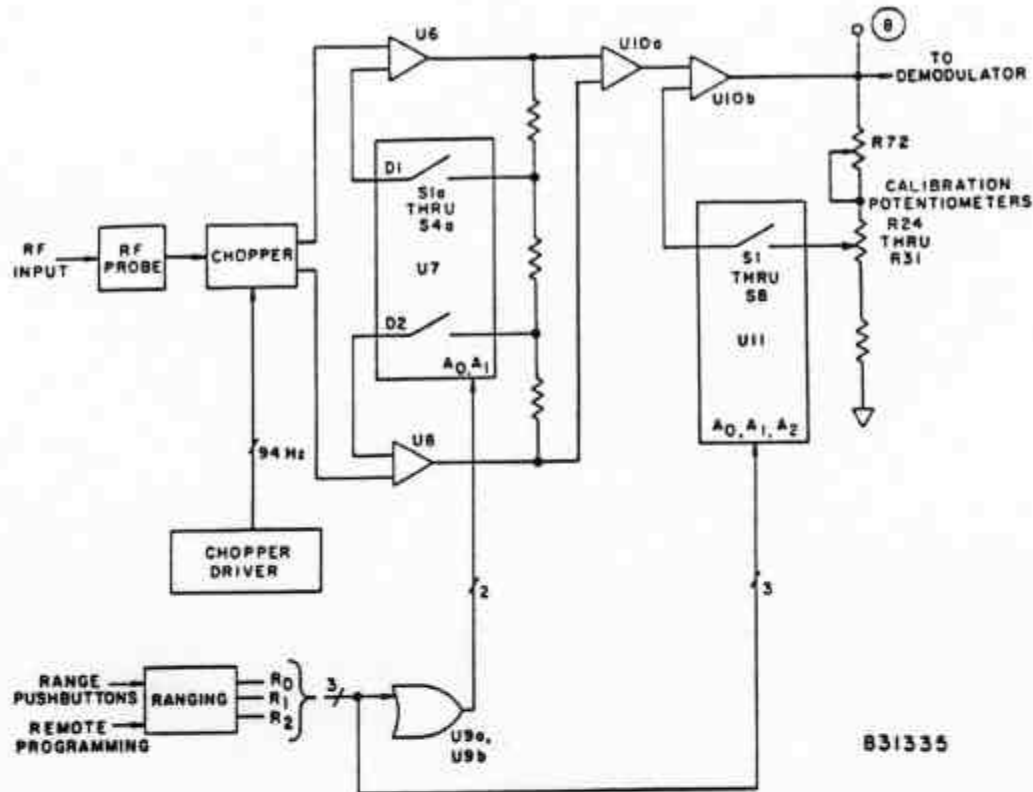

Figure 4-2. Amplifier Circuits Block Diagram

tion of the other circuits in the instrument.

4-7. DETAILED CIRCUIT DESCRIPTIONS

4-8. In the following paragraphs the circuits of the instrument are grouped by function as follows: Sensor, Analog (included chopper, amplifier, demodulation and driver), clock, ranging, shaping, and power supply.

4-9. SENSOR.

The RF probes used with the instruments are unterminated, high input-impedance devices. The RF voltage applied to the probes is rectified by a full-wave detector employing factory selected diodes with special characteristics, including low capacitance and controlled thermal offsets. The resulting DC voltage is a function of the applied RF Voltage.

4-10. A full-wave detector, unlike a single diode detector, permits measurement of highly asymmetrical waveforms without substantial error. When a voltage of such waveform is impressed on a single diode detector

circuit, whether or not the portion of the waveform that "turns on" the diode is restricted to the square law region of the diode's characteristic, the recovered DC voltage is dependent upon the phase of the input voltage. Consider a positive pulse of low duty cycle applied to the anode of a diode detector. The recovered DC voltage is a function of the polarity, amplitude, and duration of the pulse. If the pulse is inverted, it drives the diode into a reverse bias condition and the recovered DC voltage is near zero. A full-wave detector circuit, on the other hand, yields an equal amount of DC irrespective of the polarity of the input pulse. The RMS voltage of a pulse obviously does not depend upon the phase of the pulse. The response of a single diode detector, square law characteristic notwithstanding, cannot reflect this; a full wave detector circuit does.

4-11. Probe response is true RMS for inputs below 30 mV. Above this voltage level, the probe response gradually changes, approaching peak-to-peak at the higher levels. However, the voltage data is digitally shaped in the instrument to indicate RMS voltage, provided that the input is reasonably sinusoidal, as is

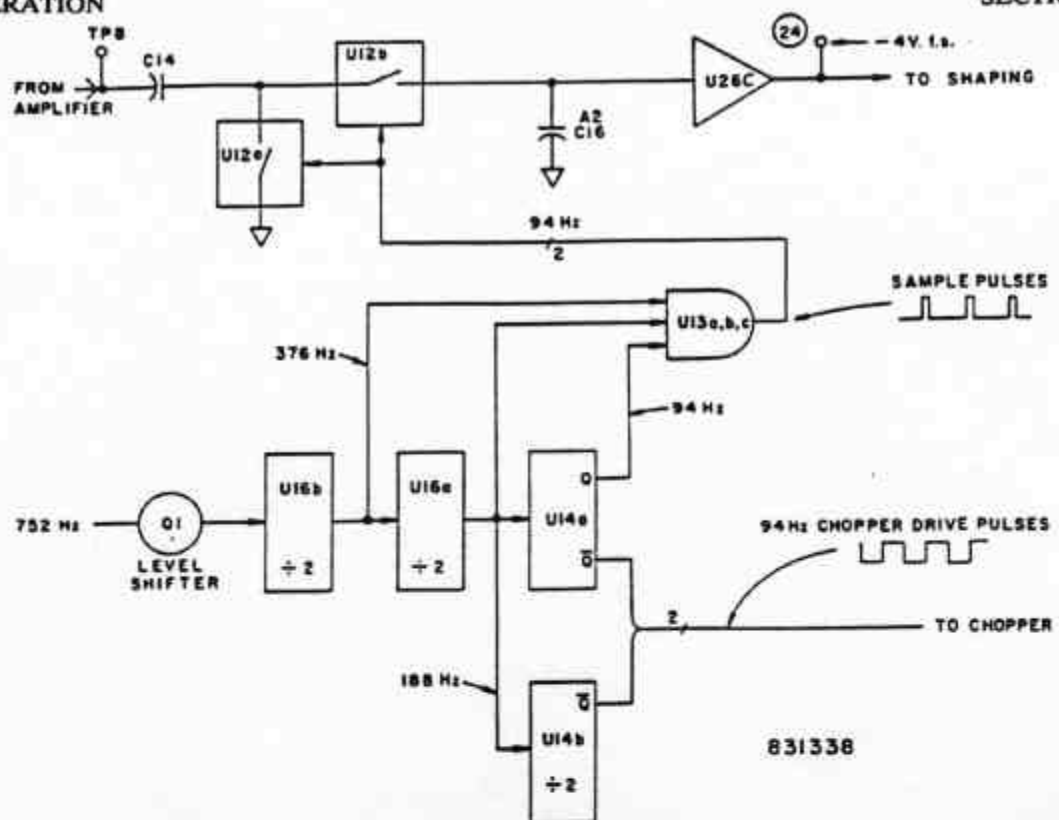

Figure 4-3. Demodulator and Driver Circuits Block Diagram

the case with CW and FM signals.

4-12. The probe body has been designed to minimize noise. The probe connects to the instrument through a low noise cable.

4-13. CHOPPER CIRCUITS.

The chopper board contains four solid state switches, which are used to convert input DC voltage to a 94 Hz square wave. The switches are controlled by 94 Hz chopper drive signals supplied from a frequency divider chain in the analog section. Potentiometers A4R4 and A4R5 provide means for adjusting the chopper to zero output with zero input. Use of a solid state chopper eliminates most of the undesirable characteristics of electromechanical choppers (e.g. contact wear, bounce, and contamination). The output of the chopper is a balanced 94 Hz square wave that is directly proportional to the DC voltage applied from the sensor.

4-14. AMPLIFIER CIRCUITS.

Refer to Figure 4-2. The balanced 94 Hz square wave signal from the chopper is amplified by operational amplifiers A2U6, A2U8, A2U10a and A2U10b. The gain of the operational amplifiers A2U6, A2U8 and A2U10a is controlled by

adjusting feedback to the amplifier through multiplexer A2U7 and a resistor network. The signals R0, R1 and R2, from the ranging section, applied through gates A2U9a and A2U9b, control the switching of input terminals D1 and D2 of multiplexer A2U7 to two of eight points in the resistance networks, thereby adjusting the feedback and the amplifier gain.

4-15. The 94 Hz output of op amps A2U6 and A2U8 is applied to the differential inputs of op amp A2U10a, which makes the signal single ended. This signal is amplified by op amp A2U10b and associated circuitry. Multiplexer A2U11 adjusts the gain of this op amp in eight steps, under control of signals R0, R1 and R2 from the ranging section, to provide decade ranging in voltage. The nominal output for a full scale input on each range is four volts, approximately, peak-to-peak (at TP8). Separate potentiometers are provided for full scale calibration of the instrument on each range. A2R72 is the Master Gain Control and A2R73 is used to adjust for any large differences in the efficiency of probes.

4-16. DEMODULATOR CIRCUITS.

Refer to Figure 4-3. A solid state demodulator, consisting of switches A2U12a and A2U12b, converts the amplified and

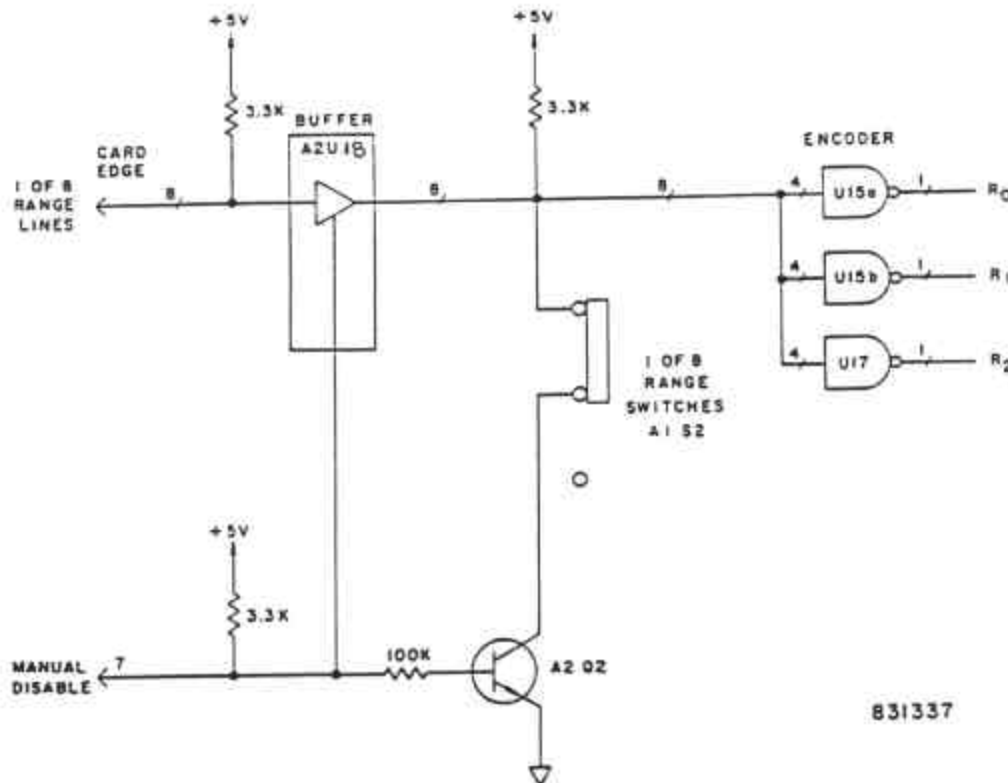

Figure 4-4. Ranging Circuits Block Diagram

scaled 94 Hz square wave signal back to DC. The demodulator is driven by a 94 Hz demodulator drive signal, which is synchronized with the 94 Hz chopper drive signal. A synchronous, sampling type demodulator circuit is used, with the sample being taken at a point well removed from the chopper switching points. The demodulator is followed by the high input impedance buffer A2U26c to reduce loading of the sampling capacitor A2C16 to negligible proportions. Output DC is supplied to A2U24c in the shaping section.

4-17. DRIVER CIRCUITS.

Chopper and demodulator drive signals are derived from a 752 Hz signal supplied from the clock circuit. A2Q1 shifts the clock voltage from the zero to plus five volt level (used by the shaping circuitry), to a +5 and -5 volt level used by the chopper circuitry. Flip-flops A2U14a, A2U14b, A2U16a and A2U16b divide down the 752 Hz signal to 94 Hz, and gates A2U13a, A2U13b and A2U13c shape the 94 Hz demodulator signal. Figure 4-3 shows the derivation of the chopper and demodulator drive signals from the 752 Hz clock signal.

4-18. CLOCK CIRCUITS.

Refer to Figure 4-5. A crystal controlled oscillator (A2U19a, b, c and crystal Y1), provides 96 kHz clock pulses. This 96

kHz square wave is frequency divided in the binary counter A2U20 to produce clock signals for both the analog and the shaping circuitry.

4-19. RANGING AND PROGRAMMING CIRCUITS.

Refer to Figure 4-4. Ranging of the instrument is performed manually by means of the eight pushbutton switches on the front panel. When a range is selected, one section of A1S2 "shorts" to ground inputs to the range encoder. The range encoder comprises A2U15a, A2U15b, and A2U17, and will generate a binary range code on lines R0, R1 and R2. This range code is used by both the amplifier circuitry and the shaping circuitry to select the appropriate signal processing.

4-20. Remote programming is accomplished by simultaneously shorting to common the Manual Disable and the appropriate range lines on the card edge connector located at the rear of the instrument. Shorting the Manual Disable line turns off A2Q2, causing the latter to disconnect the front panel switches. Shorting the Manual Disable line also enables buffer A2U18, allowing it to transmit ranging information from the card edge connector to the range encoder.

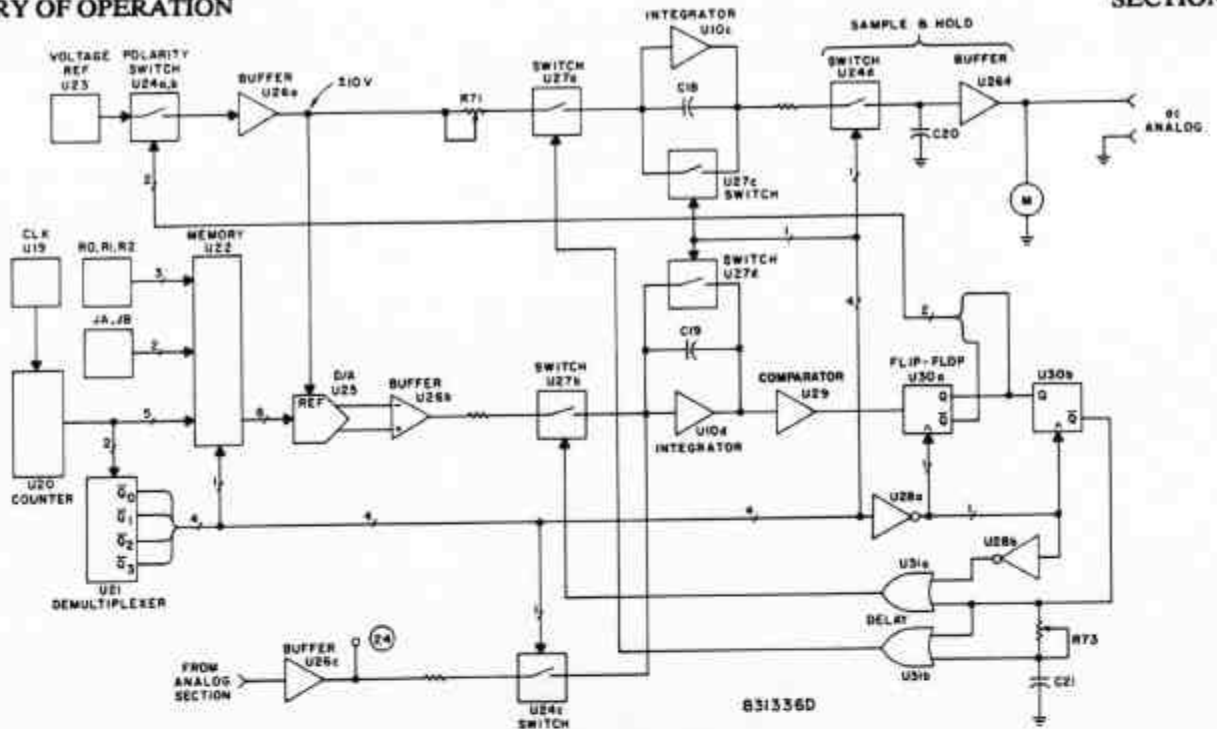

Figure 4-5. Shaping Circuits Block Diagram

4-21. SHAPING CIRCUITS.

Shaping is used to linearize the output of the diode sensor. (The conversion of RF to DC in the sensor is virtually square law for the lowest ranges, gradually becoming quasi-linear at three volts). The shaping circuit of the instrument uses data stored in ROM A2U22, and a dual slope integrator, to linearize the output of the sensor.

4-22. Shaping is achieved in four phases. Phase 0 integrates the input signal. Phase 1 combines the input with the shaping data. Phase 2 samples and holds the shaped and corrected output. Phase 3 resets the circuit for another cycle. The phases are controlled by the output of demultiplexer A2U21. Refer to Figure 4-5.

4-23. Phase 0 occurs when Q0 of the demultiplexer A2U21 is low. During this phase, the DC voltage from the demodulator is applied to the integrator A2U10d through switch A2U24c. The integrator output starts at zero before ramping to its final value. (A voltage of -4 at TP24 will cause the integrator output voltage at TP26 to be approximately +5 volts at the end of Phase 0).

4-24. Comparator A2U29 measures the polarity of the integrator at TP26 and gives an output of either 0 V or 5V for a negative or a positive integration, respectively. The polarity information is stored in flip-flop A2U30a and is used to determine the polarity of the voltage reference at pin 1 of A2U26a. A2U23 is a stable voltage source.

A2U24a and A2U24b are switches that configure amplifier A2U26a as either non-inverting or inverting, thus changing from (+) to (-) the polarity of the voltage derived from the reference.

4-25. Phase 1 occurs when Q1 of the A2U21 demultiplexer is low. This signal is inverted in A2U28a to provide a clock to the flip-flops A2U30a and A2U30b. The clock latches the polarity information into A2U30a and also sets Q2 of A2U30b low.

4-26. The Phase 1 signal addresses ROM A2U22. The ROM is addressed also by R0, R1 and R2 (the range lines, which set shaping appropriate to the range currently in use), and by JA and JB (the shaping jumpers, which program for variations in sensor shaping). ROM A2U22 also receives signals in a binary sequence from counter A2U20. Shaping data stored in the ROM are recalled and converted in DAC A2U25 into the shaping signal. The shaping signal is of the opposite polarity to the input signal. Closing switch A1U27b allows the shaping signal and the input signal to combine in the integrator. (A2U27b is closed by the Phase 1 signal "or-gated" with the output of A2U30b).

4-27. As just noted, the shaping signal and the input signal are of opposite polarity. The integrator therefore ramps toward zero volts at a rate proportional to the

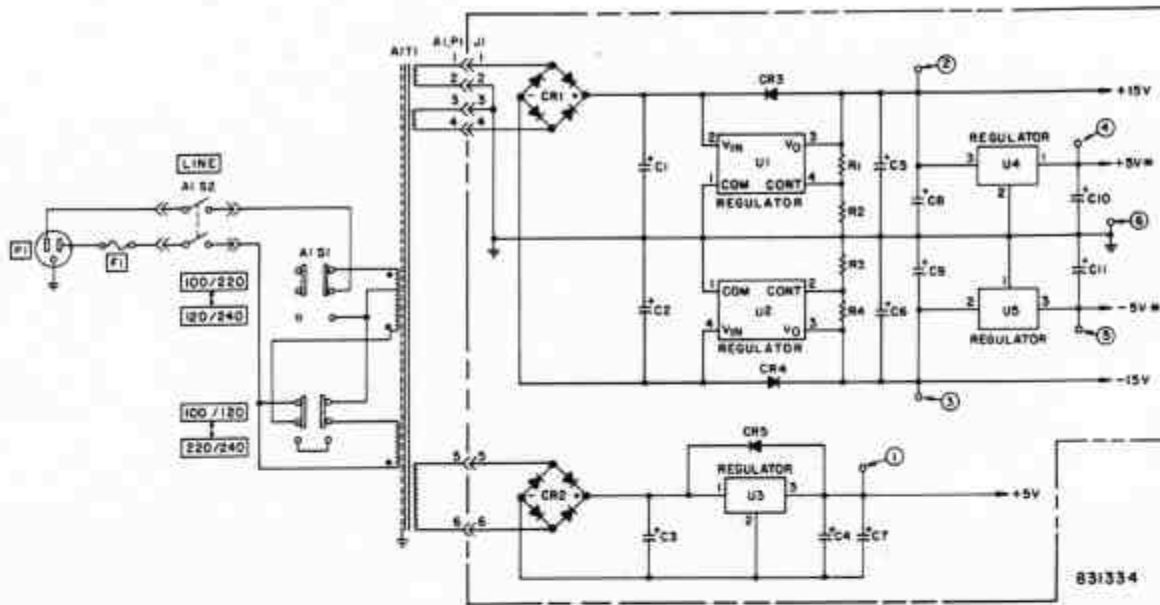

Figure 4-6. Power Supply Circuits Block Diagram

shaping signal's amplitude.

4-28. Phase 1 closes switch A2U27a, allowing the reference voltage to be integrated in A2U10c, the output integrator. The output integrator provides a shaped signal that drives the meter and the DC analog output by way of A2U26d (a high impedance unity gain buffer). The time constant of A2R69 and A2C21 delays the closing of switch A2U27a in order to mask the noise caused by the shaping process when there is zero input. A2R71 adjust for the tolerance of the integrator capacitor.

4-29. During Phase 1 the comparator A2U29 detects the zero crossing of the integrator. When the zero crossing is detected, the output integrator switch A2U27a is opened, halting the integrator A2U10c at a voltage proportional to the sum of the shaping and the input voltages. The output of the comparator, and the output of the comparator flip-flop, are "exclusive or-ed" in A2U28b. This signal resets flip-flop A2U30b, opening both switches A2U27a and A2U27b.

4-30. During Phase 2, the Q2 output of demultiplexer A2U21 closes switch A2U24d. This samples the output of integrator A2U10c and holds the voltage in A2C20.

4-31. The Q3 output of demultiplexer A2U21 closes switches A2U27c and A2U27d during Phase 3. These

switches discharge their respective integrator capacitors, leaving the integrators ready for another shaping cycle.

4-32. POWER SUPPLY CIRCUITS.

Refer to Figure 4-6. The power supply circuits provide DC operating power for all other circuits of the instrument. Regulated output voltages of +15, -15, +5 and -5 volts are supplied. Line voltages of 100, 120, 220, and 240 volts, +/- 10%, 50 to 400 Hz can be accommodated.

4-33. AC power is applied to the primary windings of power transformer A1T1 through the Line switch A1S3, and the two section line voltage switch A1S1. The latter changes the transformer primary winding connections as required to accommodate the available line voltage. Fuse A1F1 protects the power-supply circuits against overload. The voltages developed in the secondary windings of the power transformer are applied to three rectifier regulator circuits on the main printed circuit board A2.

4-34. The +15 V and -15 V supplies are similar. Input to each supply consists of 20 V, supplied by a separate secondary winding of the power transformer. In each supply, the applied AC is rectified by the bridge rectifier

A2CR1, filtered by A2C1 and by A2U1 and A2U2.

4-35. Regulated +5 V and -5V operating supplies for the chopper and analog circuits derive power from the regulated +15V and the -15 V supplies, using regulators A2U4 and A2U5. Thus, the supplies for these more sensitive circuits are isolated from the less sensitive circuits.

4-36. Regulated +5 V for the digital circuits is provided by a separate 5 VDC supply, powered by the third secondary winding of the power transformer. This further isolates the sensitive input circuitry from noise caused by the digital circuitry. The applied AC is rectified by the bridge rectifier A2CR2 to develop 11 VDC, at A2C3. This filtered DC is converted to +5 V by regulator A2U3.

SECTION V

MAINTENANCE

5-1. INTRODUCTION

5-2. This section contains the safety requirements, test equipment required, cleaning procedures, removal and replacement procedures, inspection procedures, adjustment procedures (calibration) and troubleshooting for the Model 92EA.

5-3. SAFETY REQUIREMENTS

5-4. Although this instrument has been designed in accordance with international safety standards, general safety precautions must be observed during all phases of operation and maintenance of the instrument. Failure to comply with the precautions listed in the Safety Summary located in the front of this manual could result in serious injury or death. Service and adjustments should be performed only by qualified service personnel.

5-5. TEST EQUIPMENT REQUIRED

5-6. Test equipment required for the performance tests, adjustments and troubleshooting is listed in Table 5-1.

5-7. CLEANING PROCEDURE

5-8. CLEANING.

Painted surfaces can be cleaned with a commercial, spray-type window cleaner or with a mild soap and water solution.

CAUTION

Avoid the use of chemical cleaning agents which might damage the plastics used in the instrument. The recommended cleaning agents is a solution of 1% mild detergent and 99% water.

5-9. REMOVAL & REPLACEMENT PROCEDURES

5-10. INSTRUMENT COVERS.

Remove the instrument covers as follows:

- a. Disconnect the power cord and all cables from the instrument.

- b. Remove the two screws located at the rear of the cover.
- c. Slowly lift the cover up and to the rear.
- d. Turn the instrument over and remove the bottom cover in the same manner as the top cover was removed.
- e. To replace the covers reverse the removal procedure.

5-11. RF PROBE REPLACEMENT.

If it is necessary to change probes for any reason, the instrument's calibration **MUST** be rechecked. In most cases, the instrument must be recalibrated. If the RF Probe supplied with the instrument is exchanged for a Low Frequency Probe, recalibration is required.

5-12. INSPECTION PROCEDURE

5-13. If an equipment malfunction occurs, perform a visual inspection of the instrument and RF probe. Inspect for signs of damage caused by excessive shock, vibration, or overheating, such as broken wires, loose hardware and parts, loose electrical connections, electrical shorts, cold solder connections, or accumulations of dirt and other foreign matter. Correct any problems discovered, then perform the performance tests to verify that the instrument is operational. If a malfunction persists or the instrument fails any of the performance tests, refer to the adjustment procedures. After it has been adjusted, perform the performance tests again to verify instrument operation. If the instrument can not be adjusted, or fails the performance tests refer to the troubleshooting procedure.

5-14. PERFORMANCE TESTS

5-15. POWER SUPPLY TESTS.

Improper operation of the instrument may be caused by incorrect DC operating voltages. Perform the power supply tests as follows.

WARNING

Line voltages up to 240 volts, AC may be encountered in the power supply circuits. To protect against electri-

TABLE 5-1. MAINTENANCE TEST EQUIPMENT

EQUIPMENT	SPECIFICATIONS	SUGGESTED MODEL
Signal Generator	125 kHz - 175 MHz 450 kHz - 1040 MHz 10 MHz - 1400 MHz	Boonton Model 103D Boonton Model 102F-20 HP 8660 A/C
Calibrator	1 MHz - +/- 0.5%	Boonton Model 26A
Slotted line	50 ohm, 300 MHz - 9 GHz	GR Type 900 LB
Detector	.1 MHz - 1200 MHz 40 MHz - 2030 MHz	Boonton Model 9200B GR Type 1241
Power Splitter	Type N, DC to 18 GHz Type N, DC to 18 GHz Type N, DC to 2000 MHz	HP 11667A Weinschel Model 1870A MicroLab/FXR DA-4FN
RF Power Meter	.1MHz-18GHz, 1.2% acc. .1 MHz-26.5GHz, 1.2% acc.	Boonton 4200 HP4355B
Sweep Generator	Frequency range: 0.01 to 2600 MHz 10 kHz - 2600 MHz	Wavetek 2001 HP 8660 A/C
SWR Autotester	50 ohm, 10 MHz - 4 GHz	Wiltron Model 63NP50
Oscilloscope	100 MHz, 2 channel	Tektronix Model 5103N
Standard Mismatch	Male, Type N 1.2:1 VSWR DC to 18 GHz	Maury Microwave Model 2562C
DVM	3.5 digit, .1% accuracy	Data Precision Model 1350

cal shock, observe suitable precautions when connecting and disconnecting test equipment, and when making voltage measurements.

- a. Refer to paragraph 5-9 Removal and Replacement Procedures and remove the instrument covers.
- b. Use a voltmeter and measure the voltage at the test points listed in Table 5-2.

TABLE 5-2. POWER SUPPLY TEST POINTS

Test Point	Voltage
AZTP1	+ 5.0 +/- 5% VDC
AZTP2	+15.0 +/- 5% VDC
AZTP3	- 15.0 +/- 5% VDC
AZTP4	+ 5.0 +/- 5% VDC
AZTP5	- 5.0 +/- 5% VDC

5-16. INSTRUMENT CALIBRATION TEST.

Check the calibration of the instrument on each range using a test voltage equal to the full scale value.

5-17. PROBE TESTS.

If a probe exhibits out of tolerance performance in these tests, the user is urged not to attempt repair but to send the probe back to the factory for repair or replacement.

5-18. PROBE SWR TEST.

- a. Test equipment required: (Refer to Table 5-1).

1. Signal Generator.
2. Slotted Line.
3. Detector

5-19. Perform the test as follows:

- a. Connect the slotted line to a proper signal source, and terminate the line with the device to be tested, i.e., Boonton Model 952003-A Tee Adapter and Boonton Model 91-15A 50 ohm Termination, or Boonton Model 952002-A 50 ohm Adapter.

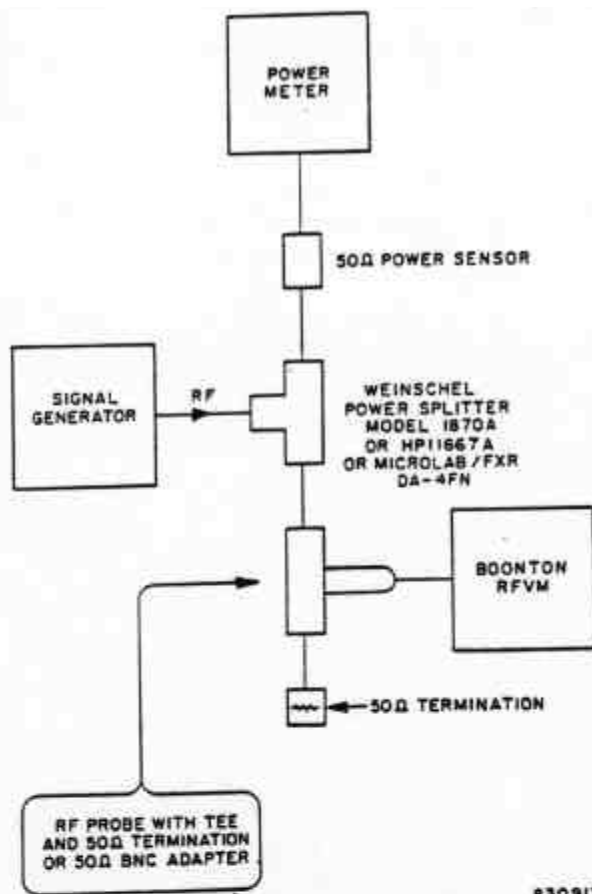

830917

Figure 5-1. Frequency Response Test Setup

b. The probe and RF Millivoltmeter must be connected to the accessory being tested. The probe supplies a perturbation for which the accessory was designed, and which it needs, to meet its specification. The millivoltmeter permits the test level to be set to the desired value.

c. Move the carriage of the slotted line to a point of minimum voltage, then to a point of maximum voltage, and record the values.

d. The SWR is the ratio of the maximum and the minimum voltages. The measurement can be repeated at other frequencies and levels, as required.

5-20. PROBE FREQUENCY RESPONSE TEST.

a. Test equipment required: Refer to Table 5-1.

1. Sweep Generator.
2. Power Splitter.
3. Calibrated RF Power Meter.

5-21. Perform the test as follows:

a. Connect the equipment as shown in figure 5-1.

b. Set the frequency of the generator to 10 MHz, and adjust the output control for the desired test level. If the response is to be measured at one level only, a test voltage of 100 or 200 mV is recommended.

c. Disable the output of the generator momentarily and zero the power meter. Re-establish the output level and note the reading on the power meter. Record the frequency of the generator and the reading of the instrument. Change the frequency, in whatever increments are desired, through the range of 10 to 1200 MHz, holding the reference reading on the power meter constant.

d. Reverse the output ports of the power splitter and repeat Step c.

e. The correct voltmeter reading is obtained at each frequency by averaging the two readings. This virtually eliminates the influence of frequency differences of the two ports of the power splitter.

f. Further refinements can be made by filtering the output

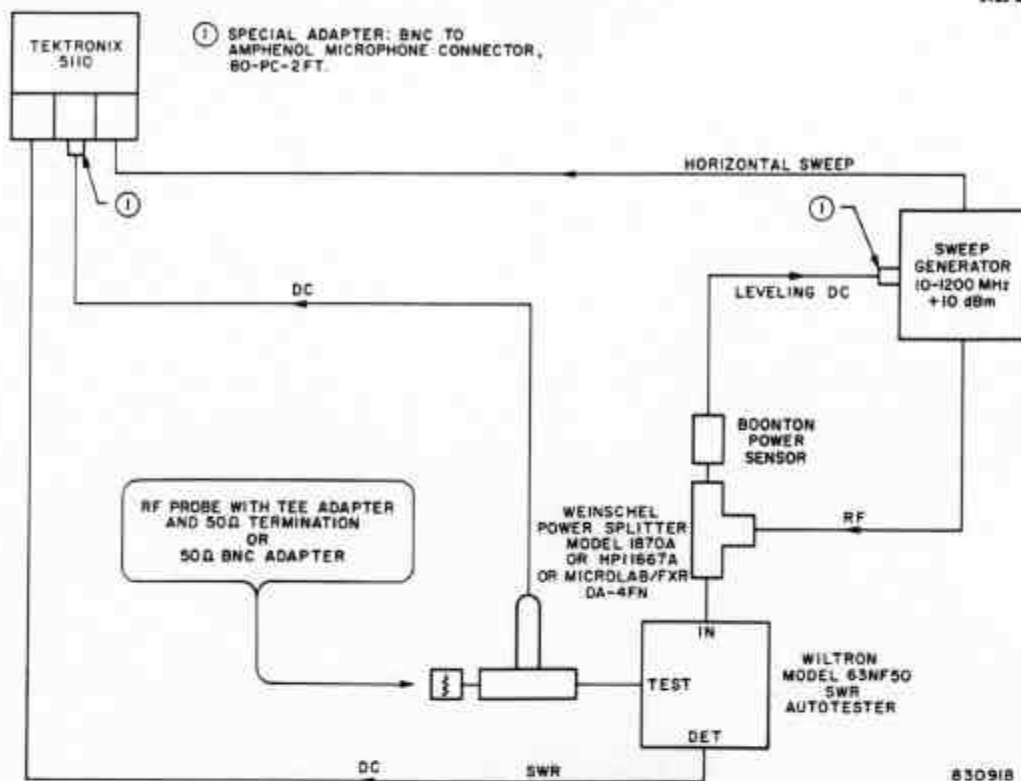

Figure 5-2. Swept Frequency Response Test Setup

of the generator, and measuring the complex reflection coefficients of the power meter, RF millivoltmeter accessory under test, and all ports of the power splitter. The usual corrections can then be made. These procedures are not usually necessary, and should be done only if the additional accuracy is warranted.

5-22. SWEPT FREQUENCY RESPONSE AND SWR TEST.

a. Test equipment required: (Refer to Table 5-1)

1. Sweep Generator.
2. SWR Autotester.
3. Oscilloscope.
4. Power Splitter.
5. Standard 1.2:1, Mismatch Termination.

5-23. Perform the test as follows:

a. Connect the equipment as shown in Figure 5-2, and temporarily connect the probe under test to the instrument. Adjust the output control of the sweep generator for a read-

ing of the instrument of 100 mV at a fixed frequency of 100 MHz.

b. Calibrate one of the scope's vertical input amplifiers for a sensitivity of 100 uV/div. The other vertical amplifier should be calibrated so that a change from 100 mV to 90 mV applied to the input of the probe under test will produce a vertical deflection of two divisions. This can be done easily if a Boonton Model 26A RF Millivoltmeter Calibrator is available. The probe should be temporarily connected to the output of the calibrator while output levels of 100 mV and 90 mV are alternately selected, and the sensitivity of the second input amplifier is adjusted for a deflection of two divisions.

c. Substitute the Standard 1.2:1 Mismatch Termination for the accessory under test, and calibrate the graticule of the oscilloscope for an SWR of 1.2. Replace the accessory and probe

d. Adjust the limits on the three bands of the sweep generator for coverage from 10 to 1200 MHz. Study the traces for both frequency response and SWR (return loss).

e. Reverse the output ports of the power splitter and repeat Steps c and d.

f. Note that the permissible error for the frequency-response trace expands with frequency. For meaningful

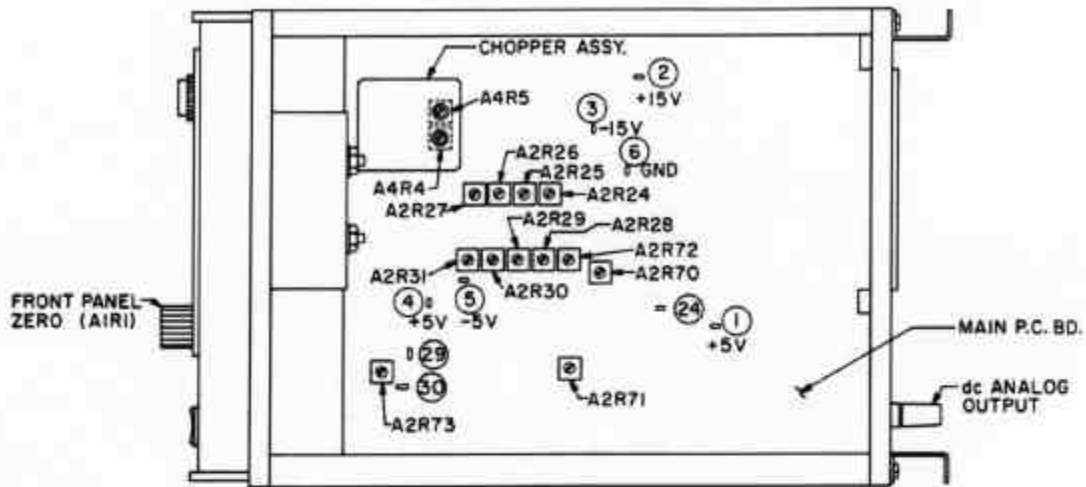

831340E

ADJ NO	CONT	FUNCTION	RANGE	INPUT ± 0.5 %	ADJUST	
1	A4R4 A4R5	CHOPPER ADJ	1 mV	0	AVERAGE OF ZERO V _{dc} @ (24)	
2	A2R73	DELAY ADJ	1000 mV	1000 mV	165 μs @ (29) FROM (50)	
3	AIRI	FRONT PANEL ZERO	1 mV	0	AVERAGE ZERO INDICATION	
4	A2R72	MASTER GAIN ADJ	—	—	4.00V AT (24)	
5	A2R27	RANGE ADJ	1 mV	1 mV		
6	A2R26	RANGE ADJ	3 mV	3 mV		
7	A2R25	RANGE ADJ	10 mV	10 mV		
8	A2R24	RANGE ADJ	30 mV	30 mV		
9	A2R31	RANGE ADJ	100 mV	100 mV		
10	A2R30	RANGE ADJ	300 mV	300 mV		
11	A2R70	METER FS ADJ	1000 mV	1000 mV		
12	A2R28	RANGE ADJ	3000 mV	3000 mV		
13	A2R71	OUTPUT INTEGRATOR ADJ	1000 mV	1000 mV		WITH 4.00V @ (24) ADJUST dc ANALOG FOR 10.00V
14	A2R29	RANGE ADJ	1000 mV	1000 mV		+ 10.00V AT dc ANALOG TERMINALS DC VOLTMETER INPUT ≥ 10M OHMS
15	A2R70	METER FS ADJ	1000 mV	1000 mV		1000 mV INDICATION
16	A2R28	RANGE ADJ	3000 mV	3000 mV	3000 mV INDICATION	
17	A2R27	RANGE ADJ	1 mV	1 mV	1.000 mV INDICATION	
18	A2R26	RANGE ADJ	3 mV	3 mV	3.000 mV INDICATION	
19	A2R25	RANGE ADJ	10 mV	10 mV	10.00 mV INDICATION	
20	A2R24	RANGE ADJ	30 mV	30 mV	30.00 mV INDICATION	
21	A2R31	RANGE ADJ	100 mV	100 mV	100.0 mV INDICATION	
22	A2R30	RANGE ADJ	300 mV	300 mV	300.0 mV INDICATION	

Figure 5-3. Adjustment Locations and Descriptions

results, the graticule should be marked with a grease pencil, showing maximum permissible errors for the various frequency bands as determined with a calibrated signal of, for example, 1 MHz, and at levels above and below the selected test level. Note also that the recovered DC from the RF probe, which is applied to the second vertical amplifier, will vary as the square of the RF input level for test levels of 30 mV or less. Above 30 mV, the RF to DC conversion gradually changes from square law to linear, and approaches a peak-to-peak rectifier at an input of 3 volts.

5-24. ADJUSTMENTS (Refer to Figure 5-3.)

5-25. CHOPPER ADJUSTMENTS.

Perform the adjustments as follows:

NOTE

The instrument must be turned on for not less than one hour and the instrument and its sensor must be at an ambient temperature of 21 C to 25 C.

- a. Refer to paragraph 5-9 Removal and Replacement Procedures and remove the top instrument cover.
- b. Remove the instrument "zero" potentiometer connector, A1P1.
- c. Connect the sensor to the adjustable signal source and set the output of the source to zero.
- d. Set the two chopper adjustments, A4R4 and A4R5, to their physical midpoints.
- e. Connect the precision voltmeter to TP24 and note the indication.
- f. Adjust the A4R4 to decrease the voltmeter's indication of one half of that in Step d.
- g. Adjust A4R5 to bring the indication to zero. There will be some fluctuation of the indication and averaging will be required.
- h. Re-connect the "zero" potentiometer connector, A1P1.

5-26. DELAY ADJUSTMENT.

Perform the adjustment as follows:

- a. Adjust A2R73 so that the falling edge of the square wave at TP29 is delayed 165 ms with respect to the falling edge of

the square wave at TP30.

5-27. ZEROING ADJUSTMENT.

Perform the adjustment as follows:

- a. Turn the instrument "off" for at least one minute. If the meter pointer does not come to rest at zero, use the zero adjustment screw in the lower center of the meter to bring the pointer to zero. Turn the instrument "on"; be sure that the instrument has stabilized at room temperature at least five minutes before the following calibration is performed.

- b. Set the instrument FULL SCALE range selector to the 1 mV range and zero the instrument.

5-28. MASTER GAIN ADJUSTMENTS.

Perform the adjustment as follows:

- a. Set A2R72 to the midpoint of its range.
- b. Set the FULL SCALE range selector to the 1 mV range, apply 1.000 mV input and adjust A2R27 for -4.00 V at TP24.
- c. Set the FULL SCALE range selector to the 3 mV range, zero the instrument, apply 3.000 mV input, and adjust A2R26 for -4.00 V at TP24.
- d. Set the FULL SCALE range selector to the 10 mV range, zero the instrument, apply 10.00 mV input, and adjust A2R25 for -4.00 V at TP24.
- e. Set the FULL SCALE range selector to the 30 mV range, apply 30.00 mV input, and adjust A2R24 for -4.00 V at TP24.
- f. Set the FULL SCALE range selector to the 100 mV range, apply 100.0 mV input, and adjust A2R31 for -4.00 V at TP24.
- g. Set the FULL SCALE range selector to the 300 mV range, apply 300.0 mV input, and adjust A2R30 for -4.00 V at TP24.
- h. Set the FULL SCALE range selector to the 1000 mV range, apply 1000 mV input, and adjust A2R29 for -4.00 V at TP24.
- i. Set the FULL SCALE range selector to the 3000 mV range, apply 3000 mV input, and adjust A2R28 for -4.00 V at TP24.

5-29. OUTPUT INTEGRATOR ADJUSTMENTS

Perform the adjustments as follows:

- a. Set the FULL SCALE range selector to the 1000 mV range, apply 1000 mV input and check for $-4.00 \pm .10$ V at TP 24. If the reading is not within tolerance repeat the Master Gain adjustments. If the reading is within tolerance perform step b.
- b. Adjust A2R71 for 10.00 V at the DC ANALOG output.

5-30. RANGE ADJUSTMENTS.

Perform the adjustments as follows:

- a. Set the FULL SCALE range selector to the 100 mV range and apply 1000 mV input, adjust A2R29 for + 10.00 V at the DC ANALOG terminals.
- b. Set the FULL SCALE range selector to the 1000 mV range and apply 1000 mV input, observe the panel meter and adjust A2R70 for 1000 mV.
- c. Set the FULL SCALE range selector to the 3000 mV range and apply 3000 mV input, observe the panel meter and adjust A2R28 for 3000 mV.
- d. Set the FULL SCALE range selector to the 1 mV range, zero the instrument, apply 1.00 mV input, observe the panel meter and adjust A2R27 for 1.00 mV.
- e. Set the FULL SCALE range selector to the 3 mV range, zero the instrument apply 3.00 mV, observe the panel meter and adjust A2R26 for 3.00 mV.
- f. Set the FULL SCALE range selector to the 10 mV range, zero the instrument, apply 10.00 mV, observe the panel meter and adjust A2R25 for 10.00 mV.
- g. Set the FULL SCALE range selector to the 30 mV range, apply 30.00 mV input, observe the panel meter and adjust A2R24 for 30.00 mV.
- h. Set the FULL SCALE range selector to the 100 mV range, apply 100.0 mV input, observe the panel meter and adjust A2R31 for 100.0 mV.
- i. Set the FULL SCALE range selector to the 300 mV range, apply 300.0 mV input, observe the panel meter and adjust A2R30 for 300.0 mV.

5-31. TROUBLESHOOTING

5-32. Instrument malfunction will generally be evident from front panel indications. The problems will fall into two general categories: selective failure of one subsystem or catastrophic failure.

5-33. Selective failure of one section of the instrument or out of specification performance will be evident from manipulation of the front panel controls. For example, incorrect or erratic indications would be evident from the display readings.

5-34. Catastrophic failures, on the other hand, would generally cause the instrument to be completely inoperative. For instance, if the power supply was not operating properly, the instrument would not operate.

5-35. Further isolation of the problem requires some understanding of the simplified block diagram. Refer to Section IV, read over the theory of operation and then try to perform the adjustment procedures as some apparent malfunctions may be corrected by these adjustments. Failure to obtain a correct adjustment will often help to reveal the source of trouble. If this does not correct the problem proceed with the troubleshooting section below. When the problem is localized to a specific assembly or module refer to the troubleshooting procedure as listed in Table 5-3 Troubleshooting Chart.

WARNING

Read the safety summary located at the front of this manual before attempting any troubleshooting procedures.

5-36. TROUBLE LOCALIZATION

5-37. Many malfunctions are evident from the front panel meter. Other front panel indications might include erratic or incorrect meter readings. In each case the circuit most closely associated with the malfunction should be tested first.

5-38. Before troubleshooting the instrument refer to paragraph 5-9, Removal and Replacement Procedures and remove the top and bottom instrument covers.

TABLE 5-3. TROUBLESHOOTING CHART.

Symptom	Troubleshoot
<p>INSTRUMENT CAN NOT BE ZEROED/ NO RESPONSE TO RF INPUT/ INCORRECT RESPONSE TO RF INPUT</p>	<p>Probe Troubleshooting (Refer to Paragraph 4-9).</p> <p>a. Disconnect the probe from the instrument and measure the resistance between the two pins of the probe connector. The probe should read 10k to 20k ohms in one direction and infinite resistance in the other direction.</p> <p>b. If the probe resistance is not within tolerance, replace the probe. Refer to paragraph 5-24, perform the Adjustment Procedure and paragraph 5-17, perform the Probe Tests.</p> <p>c. If the probe resistance is within tolerance, refer to paragraph 5-24, perform the Adjustment Procedure and paragraph 5-17, perform the Probe Tests.</p> <p>d. If the instrument fails any part of the adjustment procedure, refer to the specific circuitry troubleshooting procedure where the adjustment failed.</p>
<p>NO READINGS/ ERRATIC READINGS</p>	<p>Power Supply Circuitry Troubleshooting. Refer to paragraph 4-36, Figures 4-6 and 7-2.</p> <p>a. Verify that the power cord is connected to the instrument and an appropriate power source.</p> <p>b. Verify that the LINE ON/OFF power switch is set to On and the LED is lit.</p> <p>c. Verify that the line selector switches are set for the proper voltage.</p> <p>d. Verify that the fuse has not blown, and the proper fuse is installed.</p> <p>e. Refer to paragraph 5-15 and perform the Power Supply Tests.</p> <p>f. Troubleshoot the Power Supply Circuitry.</p> <p>g. If the Power Supply circuitry tests OK, refer to paragraph 5-24 and perform the Adjustment Procedure.</p>
<p>NO READINGS/ ERRATIC READINGS/ CAN NOT ZERO THE INSTRUMENT</p>	<p>Chopper Circuitry Troubleshooting. Refer to paragraph 4-13, Figure 4-2 and 7-6.</p> <p>a. Connect the oscilloscope probe to TP8.</p> <p>b. Apply an appropriate full scale voltage to each range, observe the oscilloscope and verify that the proper voltage and waveform is present.</p>

TABLE 5-3. TROUBLESHOOTING CHART. (CONT')

Symptom	Troubleshoot
<p>NO READINGS/ ERRATIC READINGS</p>	<p>c. If the voltage and waveform are incorrect, troubleshoot the amplifier circuitry.</p> <p>d. If the voltage and waveform are correct, continue troubleshooting.</p> <p>Amplifier Circuitry Troubleshooting. Refer to Paragraph 4-14, Figure 4-2 and 7-4.</p> <p>a. Connect the oscilloscope probe to TP8.</p> <p>b. Apply an appropriate full scale voltage to each range, observe the oscilloscope and verify that the proper voltage and waveform is present.</p> <p>c. If the voltage and waveform are incorrect, troubleshoot the amplifier circuitry.</p> <p>d. If the voltage and waveform are correct, continue troubleshooting.</p>
<p>NO READINGS/ ERRATIC READINGS</p>	<p>Demodulator Circuitry Troubleshooting. Refer to Paragraph 4-16, Figure 4-3 and 7-4.</p> <p>a. Set the instrument to the 1000 mV range.</p> <p>b. Apply 1000 mV RMS to the probe.</p> <p>c. Connect a DVM to TP24 and verify that -4.0 VDC is present.</p> <p>d. Apply 0 V to the probe.</p> <p>e. Connect a DVM to TP24 and verify that 0 VDC is present.</p> <p>f. If the voltage and waveform are incorrect, troubleshoot the demodulator circuitry.</p> <p>g. If the voltage and waveform are correct, continue troubleshooting.</p>
<p>NO READINGS/ ERRATIC READINGS</p>	<p>Shaping Circuitry Troubleshooting. Refer to Paragraph 4-13, Figure 4-2 and 7-5.</p> <p>a. Set the instrument to the 1000 mV scale.</p> <p>b. Apply 1000 mV RMS to the probe.</p> <p>c. Connect a DVM to TP24 and verify the -4.0 VDC is present.</p> <p>d. Connect the oscilloscope probe to TP21 through TP29 and verify that the proper voltages and waveforms are present.</p>

TABLE 5-3. TROUBLESHOOTING CHART. (CONT)

Symptom	Troubleshoot								
<p>NO READINGS/ ERRATIC READINGS</p>	<p>e. If the voltages and waveforms are incorrect troubleshoot the shaping circuitry.</p> <p>f. If the voltages and waveforms are correct continue troubleshooting.</p> <p>Meter Circuitry Troubleshooting. Refer to Figure 4-1 and 7-1.</p> <p>a. Connect the DVM to the rear panel DC ANALOG OUTPUT.</p> <p>b. Set the instrument to the 1000 mV range.</p> <p>c. Apply the following levels to the probe and verify that the DVM indicates as follows:</p> <table data-bbox="641 808 876 924"> <thead> <tr> <th>Level</th> <th>DVM</th> </tr> </thead> <tbody> <tr> <td>200mV</td> <td>2 V</td> </tr> <tr> <td>600mV</td> <td>6 V</td> </tr> <tr> <td>1000mV</td> <td>10 V</td> </tr> </tbody> </table> <p>d. If the voltages are incorrect troubleshoot meter circuitry.</p> <p>e. If the voltages are correct continue troubleshooting.</p>	Level	DVM	200mV	2 V	600mV	6 V	1000mV	10 V
Level	DVM								
200mV	2 V								
600mV	6 V								
1000mV	10 V								
<p>NO READINGS/ ERRATIC READINGS</p>	<p>Clock Circuitry Troubleshooting. Refer to Paragraph 4-18, Figure 4-5, 7-4 and 7-5.</p> <p>Driver Circuitry Troubleshooting. Refer to Paragraph 4-17, Figure 4-3, 7-4 and 7-5.</p> <p>a. Connect the oscilloscope probe to TP21, TP20, TP9 through TP11, TP13 through TP19 and verify that the proper voltages and waveforms are present.</p> <p>b. If the voltages and waveforms are incorrect, troubleshoot the clock or driver circuitry.</p> <p>c. If the voltages and waveforms are correct, continue troubleshooting.</p>								
<p>NO RANGING OR RESPONSE TO PUSHBUTTONS OR REMOTE PROGRAMMING</p>	<p>Ranging Circuitry Troubleshooting. Refer to Paragraph 4-19, Figure 4-4, 7-4 and 7-5.</p> <p>a. Connect the oscilloscope probe to the following pins and verify that the following levels are present for each range.</p>								

TABLE 5-3. TROUBLESHOOTING CHART. (CONT')

Symptom	Troubleshoot				
	Range	mV	U17 Pin 13 R0	U15b Pin 1 R1	U15a Pin 13 R2
	0	1	0	0	0
	1	3	1	0	0
	2	10	0	1	0
3	30	1	1	0	
4	100	0	0	1	
5	300	1	0	1	
6	1000	0	1	1	
7	3000	1	1	1	
		1 = 5V	0 = 0V		
		<p data-bbox="600 819 1282 882">b. If the voltages and waveforms are incorrect, troubleshoot the ranging circuitry.</p> <p data-bbox="600 903 1266 966">c. If the voltages and waveforms are correct, continue troubleshooting.</p>			

SECTION VI
PARTS LIST

6-1. INTRODUCTION

Table 6-1. Manufacturer's Federal Supply Code Numbers list the manufacturer's federal supply numbers.

Table 6-2. Replaceable Parts. Lists all the replaceable parts and includes; the reference symbol, description, Mfr., Mfr's Part No., and the BEC Part No.

TABLE 6-1. MANUFACTURER'S FEDERAL SUPPLY CODE NUMBERS.

NUMBER	NAME	NUMBER	NAME
01121	Allen Bradley	28480	Hewlett-Packard Corp.
01295	Texas Instruments	32293	Intersil, Inc.
02260	Amphenol	32575	AMP
02735	RCA Solid State Div.	34430	Monsanto
04713	Motorola Semiconductor	51640	Analog Devices, Inc.
04901	Boonton Electronics	51791	Statek Corp.
06383	Panduit Corporation	54420	Dage-MTI
06776	Robinson Nugent, Inc.	54426	Buss Fuses
07263	Fairchild Semiconductor	55153	Dielectric Labs
13812	Dialco Div. of Ampere	56289	Sprague Electric Co.
14655	Cornell-Dubilier	57582	Kahgan
15281	General Instrument	71279	Cambridge Thermionics
16546	Centralab	71450	CTS Corp.
17856	Siliconix, Inc.	73138	Beckman Instr., Helipot Div.
19701	Mepco Electra	82389	Switchcraft
20307	Arco - Micronics	91506	Augat
27014	National Semiconductor	98291	Scaelectro Corp.
27264	Molex, Inc.	S4217	United Chemicon, Inc.
27735	F-Dyne Electronics		

TABLE 6-2. LIST OF REPLACEABLE PARTS.

REFERENCE DESIGNATOR	DESCRIPTION	FED. CODE	MANUFACTURER PART NUMBER	QTY	BEC PART NUMBER
	SUB PANEL ASSY	04901	09205300B	1	09205300B
	ZERO POT ASSY 5K	04901	09215800C	1	09215800C
	SWITCH PUSHBUTTON ASSY	04901	09205601A	1	09205601A
	SWITCH POWER ASSY	04901	09205700A	1	09205700A
	PWA '92EA' PWR SWITCH	04901	09207100A	1	09207100A
	REAR PANEL ASSY	04901	09205200B	1	09205200B
A2	PWA '92EA' MAIN	04901	09215500G	1	09215500J
A4	PWA '92EA' CHOPPER	04901	04216101G	1	04216101G
	PROBE PWA/CONTACT/CONN ASSY	04901	09171201B	1	09171201B
	PWA PROBE	04901	09171305A	1	09171305C

04216101G REV: N* (G) PWA 'COMMON' CHOPPER
MODEL: COMMON

REFERENCE DESIGNATOR	DESCRIPTION	FED. CODE	MANUFACTURER PART NUMBER	BEC PART NUMBER
C1,2	CAP PP 0.1uF 10% 100V	27735	PP1X-1-100-10	234148000
IC1	(G) IC SELECTED QUAD SWITCH	04901	534223000	534223000
P1	TERMINAL .040 OD .270 LG .062M	98291	229-1071-000-230	510038000
P2	CONNECTOR PIN	71279	460-1521-02-03-00	477400000
R3,6	RES MF 51.1K 1% 1/4W	19701	5043ED51K10F	341468000
R4,5	RES VAR 25K 10% 0.5W	73138	72PR25K	311400000
XIC1	SOCKET IC 14 PIN	91506	714AG1D	473056000

09171305C REV: A* PWA '952001B' PROBE
MODEL: 952001B

REFERENCE DESIGNATOR	DESCRIPTION	FED. CODE	MANUFACTURER PART NUMBER	BEC PART NUMBER
C1	CAP CER CHIP 1500pF 10% 100V			22444800A
C2-3	CAP CER CHIP 1000pF 10% 50V	61637	C1210C102K5XAH	224286000
CR1-2	DIODE BAT62			53021100A
R1-2(SEL)	RES CHIP 180 OHM 5% 1/8W	01121	BCD1800J	33990017A
R3-4	RES CHIP 1K 5% 1/8W	01121	BCD1001J	33990021A

09205200B REV: EF '92EA' REAR PANEL ASSY
MODEL: 92EA

REFERENCE DESIGNATOR	DESCRIPTION	FED. CODE	MANUFACTURER PART NUMBER	BEC PART NUMBER
F1	FUSE 2/10A (0.2A) 250V	54426	MDL 0.2	545508000
FH1(3)	FUSE HOLDER			482117000
P2	CONNECTOR 6 CIR	06383	CE156F22-6-C	479416000
P3	CONN F COAX BNC	54420	UG-625B/U	479123000
P4	CONNECTOR HOUSING	27264	22-01-2021	479415000
S3	SWITCH ROCKER DPDT (GRAY)		7201-51-Z-Q-E-9	46532200A
T1	TRANSFORMER POWER	04901	446071000	446071000

60470200C REV: AC '92EA' REAR PANEL UNIT
MODEL: 92EA

REFERENCE DESIGNATOR	DESCRIPTION	FED. CODE	MANUFACTURER PART NUMBER	BEC PART NUMBER
P1	CONNECTOR LINE CORD	82389	EAC309	477281000
S1	SWITCH DUAL SLIDE DPDT-DPDT	82389	47206LFR	465279000

SECTION 6

PARTS LIST

09205300B MODEL: 92EA		REV: C* '92EA' SUB PANEL ASSY		
<u>REFERENCE DESIGNATOR</u>	<u>DESCRIPTION</u>	<u>FED. CODE</u>	<u>MANUFACTURER PART NUMBER</u>	<u>BEC PART NUMBER</u>
M1	METER AND SCALE	04901	09205400A	554216000
W6	CABLE ASSY METER			09205400A

09205600A MODEL: 92EA		REV: AA SWITCH PUSHBUTTON ASSY		
<u>REFERENCE DESIGNATOR</u>	<u>DESCRIPTION</u>	<u>FED. CODE</u>	<u>MANUFACTURER PART NUMBER</u>	<u>BEC PART NUMBER</u>
S2	SWITCH PUSHBUTTON 2 POL 9 POS	04901	46529800A	46529800A
W3	CABLE ASSY RANGE SWITCH	04901	57117300B	57117300B

09205700A MODEL: 92EA		REV: AA SWITCH FINAL ASSY POWER		
<u>REFERENCE DESIGNATOR</u>	<u>DESCRIPTION</u>	<u>FED. CODE</u>	<u>MANUFACTURER PART NUMBER</u>	<u>BEC PART NUMBER</u>
W4	CABLE ASSY LED	04901	09205800A	09205800A

09207100A MODEL: 92EA		REV: BB PWA POWER SWITCH		
<u>REFERENCE DESIGNATOR</u>	<u>DESCRIPTION</u>	<u>FED. CODE</u>	<u>MANUFACTURER PART NUMBER</u>	<u>BEC PART NUMBER</u>
CR1	LED YELLOW DIFF 5082-4684	28480	HLMP-1401	536034000

09215800C MODEL: 92E,		REV: B* ZERO POT ASSY 5K		
<u>REFERENCE DESIGNATOR</u>	<u>DESCRIPTION</u>	<u>FED. CODE</u>	<u>MANUFACTURER PART NUMBER</u>	<u>BEC PART NUMBER</u>
R1(5)	RES VAR 5K 10% 2W			31144700A

09215500J REV: U* PWA '92E' MAIN
MODEL: 92E-54

REFERENCE DESIGNATOR	DESCRIPTION	FED. CODE	MANUFACTURER PART NUMBER	BEC PART NUMBER
C1-3	CAP EL 2200uF 20% 35V	57582	KSM-2200-35	283351000
C4-6,12,15	CAP EL 100uF 20% 25V	54217	SM-25-VB-101M	283334000
C7-11	CAP EL 10uF 20% 25V	54217	SM-25-VB-10-M	283336000
C13-14	CAP PE 0.1uF 10% 200V	56289	192P10492	234005000
C16,18-20	CAP PP 0.1uF 10% 100V	27735	PP1X.1-100-10	234148000
C17	CAP CER 150pF 10% 600V	16546	CE-151	224314000
C21	CAP MICA 240pF 5% 500V	14655	CD15FD241J	200506000
CR1-2	DIODE BRIDGE KBP-02	15281	KBPO2	532013000
CR3-5	DIODE 5IG 1N4001	04713	1N4001	530151000
CR6	DIODE HSCH1001 (1N6263)	28480	HSCH-1001	530174000
CR7-11	DIODE 5IG 1N914	01295	1N914	530058000
JA	CONN M 2 CKT ST .1CT	27264	22-10-2021	477361000
JB	CONN M 2 CKT ST .1CT	27264	22-10-2021	477361000
J1	HEADER 6 PIN STRAIGHT	06383	HP55156-6-C	477346000
J2,6-7	CONN M 2 CKT ST .1CT	27264	22-10-2021	477361000
J3	SOCKET SPRING COMP LEAD .072	32575	1-332070-7	479333000
J4	CONNECTOR 4 PIN STRAIGHT	27264	22-04-2041	477373000
J5	CONN M 09 CKT ST POLZ .1CT	06383	HP55100-9-C	477374000
Q1	TRANS PNP 2N3906	04713	2N3906	528076000
Q2	TRANS NPN 2N5088 BLUE	04713	2N5088	528047000
R1,12,16,	RES MF 10.0K 1% 1/4W	19701	5043ED10K00F	341400000
R2,39,57	RES MF 4.99K 1% 1/4W	19701	5043ED4K990F	341367000
R3	RES MF 2.21K 1% 1/4W	19701	5043ED2K210F	341333000
R4	RES MF 12.7K 1% 1/4W	19701	5043ED12K70F	341410000
R5	RES MF 332 OHM 1% 1/4W	19701	5043ED332R0F	341250000
R6-7	RES MF 90.9K 1% 1/4W	19701	5043ED90K90F	341492000
R8,10	RES COMP 12M 5% 1/4W	01121	CB1265	343708000
R9	RES MF 165 OHM 1% 1/4W	19701	5043ED165R0F	341221000
R11,17,45,	RES MF 100K 1% 1/4W	19701	5043ED100K0F	341500000
R13,15,19	RES MF 1.00K 1% 1/4W	19701	5043ED1K000F	341300000
R14	RES MF 221 OHM 1% 1/4W	19701	5043ED221R0F	341233000
R18,20	RES MF 8.25K 1% 1/4W	19701	5043ED8K250F	341388000
R21,38	RES MF 1.00K 1% 1/4W	19701	5043ED1K000F	341300000
R22	RES COMP 1.1M 5% 1/4W	01121	CB1155	343604000
R23,44,60,	RES MF 10.0K 1% 1/4W	19701	5043ED10K00F	341400000
R24-31,72	RES VAR 25K 10% 0.5W	73138	72PR25K	311400000
R32,35	RES MF 63.6K 1% 1/4W	19701	5043ED53K60F	341470000
R33	RES MF 78.7K 1% 1/4W	19701	5043ED78K70F	341486000
R34,59,	RES MF 20.0K 1% 1/4W	19701	5043ED20K00F	341429000
R36	RES MF 5.11K 1% 1/4W	19701	5043ED5K110F	341368000
R37	RES MF 18.7K 1% 1/4W	19701	5043ED18K70F	341426000
R40	RES MF 590 OHM 1% 1/4W	19701	5043ED590R0F	341274000
R41	RES MF 1.33K 1% 1/4W	19701	5043ED1K330F	341312000
R42	RES MF 200 OHM 1% 1/4W	19701	5043ED200R0F	341229000
R43	RES MF 267 OHM 1% 1/4W	19701	5043ED267R0F	341241000
R46	RES MF 33.2K 1% 1/4W	19701	5043ED33K20F	341450000
R47	RES MF 56.2K 1% 1/4W	19701	5043ED56K20F	341472000
R48-49	RES NETWORK 3.3K 2% 1.5W 10pin	71450	750-101-R3.3K	345030000
R50	RES MF 100K 1% 1/4W	19701	5043ED100K0F	341500000
R51,53,65	RES MF 221K 1% 1/4W	19701	5043ED221K0F	341533000
R52	RES MF 475K 1% 1/4W	19701	5043ED475K0F	341565000
R54-55	RES MF 4.75K 1% 1/4W	19701	5043ED4K750F	341365000
R56	RES MF 15.0K 1% 1/4W	19701	5043ED15K00F	341417000
R58	RES MF 511 OHM 1% 1/4W	19701	5043ED511R0F	341268000
R61-63	RES MF 20.0K 1% 1/4W	19701	5043ED20K00F	341429000

SECTION 6

PARTS LIST

09215500J REV: U* PWA '92E' MAIN (CONT.)
MODEL: 92E-S4

REFERENCE DESIGNATOR	DESCRIPTION	FED. CODE	MANUFACTURER PART NUMBER	BEC PART NUMBER
R64	RES MF 22.1K 1% 1/4W	19701	5043ED22K10F	341433000
R66	RES MF 10.0K 1% 1/4W	19701	5043ED10K00F	341400000
R67	RES MF 45.3K 1% 1/4W	19701	5043ED45K30F	341463000
R68	RES MF 9.09K 1% 1/4W	19701	5043ED9K090F	341392000
R69	RES MF 499K 1% 1/4W	19701	5043ED499K0F	341567000
R70	RES VAR 10K 10% 0.5W	73138	72PR10K	311328000
R71	RES VAR 5K 10% 0.5W	73138	72PR5K	311308000
R73	RES VAR 1M 20% 0.5W	73138	72PR1M	311418000
U1	IC 78MGUIC VOLT REG POS	27014	LM78MGCP	535042000
U2	IC 79MGUIC NEG VOLT REG	07263	uA79MGUIC	535043000
U3	IC UA7805UC VOLT REG	07263	uA7805UC	53511700A
U4	IC 78L05 VOLT REG	07263	uA78L05AWC	535044000
U5	IC 79L05 VOLT REG	04713	MC79L05ACP	535090000
U6.8	(G) IC 3568 OP AMP SELECTED	04901	535062000	535062000
U7	IC 6208 4 CHAN DIF MULTPXR	32293	IH6208CPE	534266000
U9	IC 4001B QUAD 2 INPUT NOR	02735	CD4001BE	53444721A
U10.26	IC TL074CN OP AMP QUAD	01295	TL074CN	535082000
U11	IC 6108 CMOS CHAN MULTPXR	32293	IH6108CPE	534265000
U12	IC 4066A CMOS BILAT SW	02735	CD4066AE	534078000
U13	IC 4081B 2 INPUT NAND	02735	CD4081BE	534142000
U14,16,30	IC 4013B DUAL FLIP FLOP	02735	CD4013BE	534205000
U15,17	IC 4012B CMOS NAND GATE	02735	CD4012BE	534325000
U18	IC 74LS244 OCT BUFF&LINE DRVR	01295	SN74LS244N	534247000
U19	IC 4011 QUAD 2 INPUT NAND	02735	CD4011AE	534022000
U20	IC 4040B COUNTER/DIVIDER	02735	CD4040BE	534275000
U21	IC 4556B DUAL 1 OF 4 DECODER	02735	CD4556BE	534324000
U22	PROM 92E A2 U22 MAIN	04901	53439100B	53439100B
U23	IC TL431CLP ADJ PREC SHUNT REG	01295	TL431CLP	535098000
U24.27	IC 211 QUAD SPST CMOS SWITCH	17856	DG211CJ	534326000
U25	IC 7523 D/A CONVERTER	51640	AD7523JN	535099000
U28	IC 4030B QUAD EXCLUSIVE OR	02735	CD4030BE	53444722A
U29	IC 3140 OP AMP			535910000
U31	IC 4071B CMOS 2 INPUT OR	02735	CD4071BE	534141000
XU6.8	SOCKET IC 8 PIN	06776	ICN-083-S3-G	473041000
XU7,11,20	SOCKET IC 16 PIN	06776	ICN-163-S3-G	473042000
XU10,15,19	SOCKET IC 14 PIN	06776	ICN-143-S3-G	473019000
XU17,26	SOCKET IC 14 PIN	06776	ICN-143-S3-G	473019000
XU18	SOCKET IC 20 PIN	06776	ICN-203-S3-G	473065000
XU22	SOCKET IC 24 PIN	06776	ICN-246-S4-G	473043000
XU24,27	SOCKET IC 16 PIN	06776	ICN-163-S3-G	473042000
Y1	CRYSTAL 96.00 KHz	51791	CX1H96.0-C	547036000

09215800C REV: B* ZERO POT ASSY 5K
MODEL: 92E.

REFERENCE DESIGNATOR	DESCRIPTION	FED. CODE	MANUFACTURER PART NUMBER	BEC PART NUMBER
R1(5) W7P1(4)	RES VAR 5K 10% 2W CONNECTOR HOUSING 4 CIR	27264	22-01-2047	31144700A 479429000

**SECTION VII
SCHEMATIC DIAGRAMS****7-1 TABLE OF CONTENTS**

FIGURE	PAGE
7-1 Main-Frame Assembly Schematic Diagram.....	7-3/7-4
7-2 Main PC Board (Power Supply Section), Schematic Diagram.....	7-5
7-3 Main PC Board Parts Location Diagram.....	7-6
7-4 Main PC Board Schematic Diagram, Sheet 1 of 2.....	7-7/7-8
7-5 Main PC Board Schematic Diagram, Sheet 2 of 2.....	7-9/7-10
7-6 Chopper PC Board Schematic and Parts Location Diagram.....	7-11/7-12

A1 MAIN FRAME

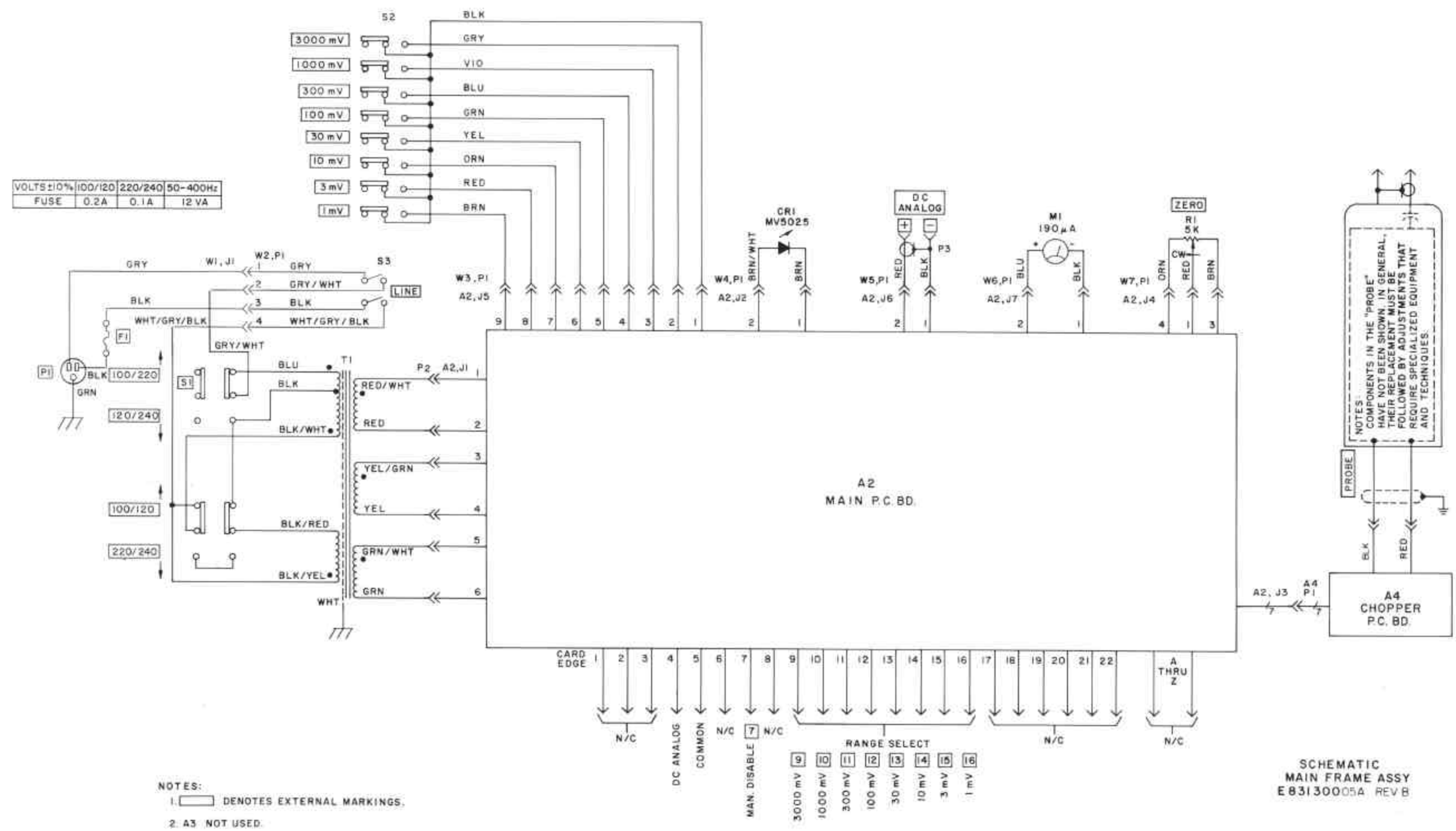

SCHEMATIC
MAIN FRAME ASSY
E83130005A REV B

Figure 7-1. Main-Frame Assembly
Schematic Diagram

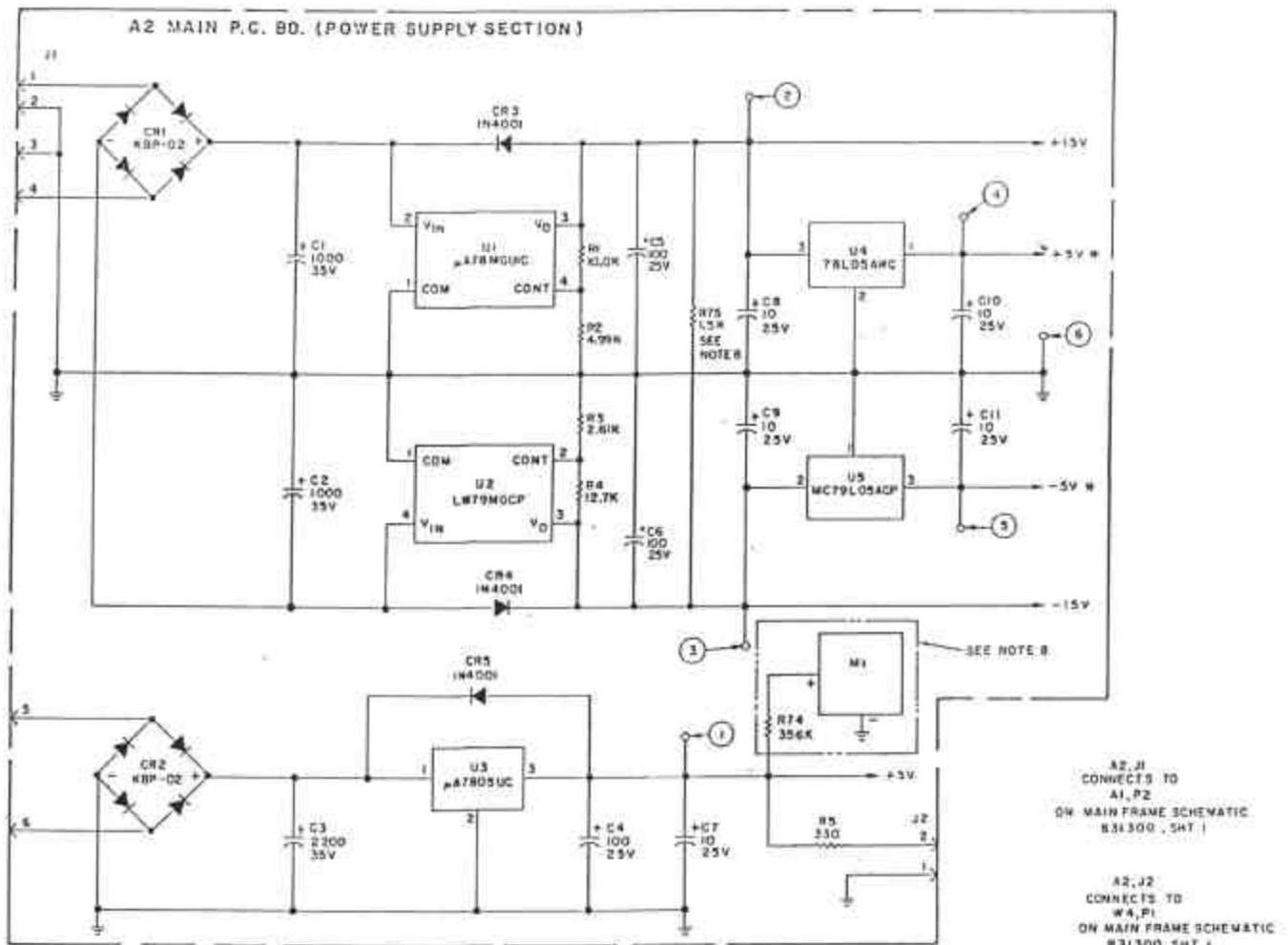

- NOTES
1. CAPACITANCE VALUES IN μ F UNLESS OTHERWISE SPECIFIED.
 2. RESISTANCE VALUES IN OHMS.
 3. $\text{\textcircled{R}}$ SELECTED VALUES.
 4. $\text{\textcircled{A}}$ ANALOG GROUND.
 5. $\text{\textcircled{D}}$ DIGITAL GROUND.
 5. JUMPER "A" & "B" DETERMINED BY SENSOR CHARACTERISTICS.
 6. LAST NUMBERS USED:
U31, R75, C21, CR11
 7. TEST CONDITIONS:
1 Vrms AT INPUT TO SENSOR.
 8. USED ON SEE/EA-S/S ONLY.

SCHMATIC
MAIN P.C. BOARD
083130002E REV.G

Figure 7-2. Main PC Board
(Power Supply Section)

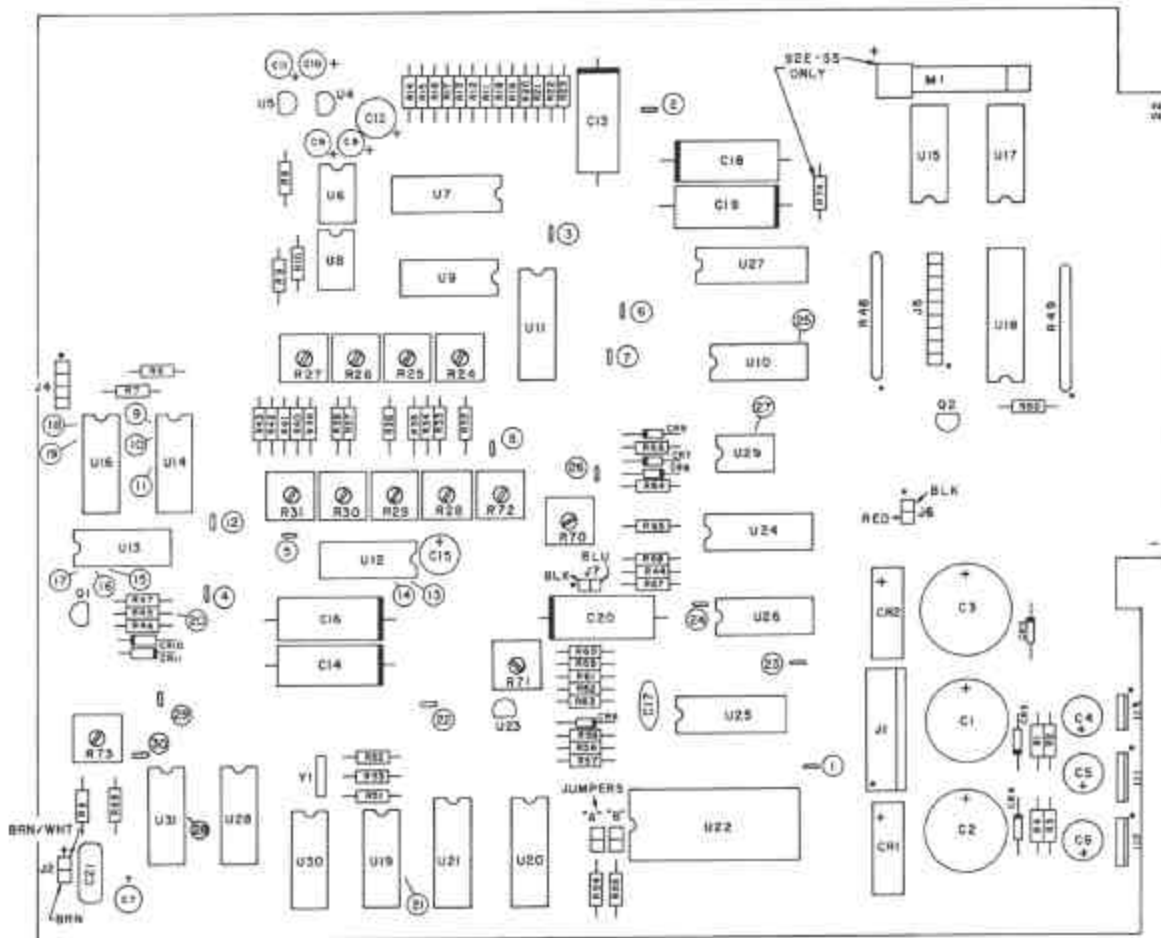

631301F

Figure 7-3. Main PC Board
Parts Location Diagram

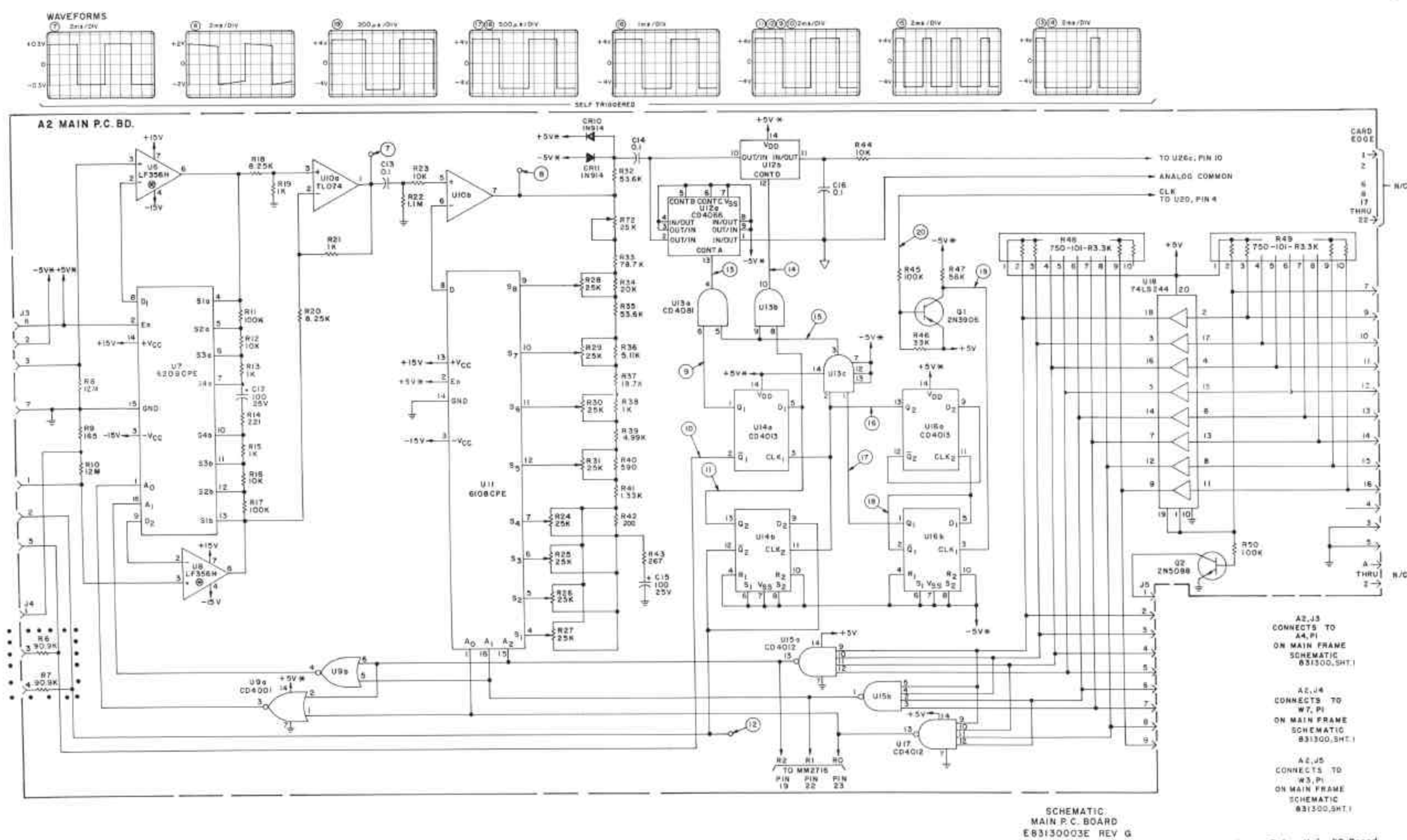

Figure 7-4. Main PC Board Schematic Diagram Sheet 1 of 2

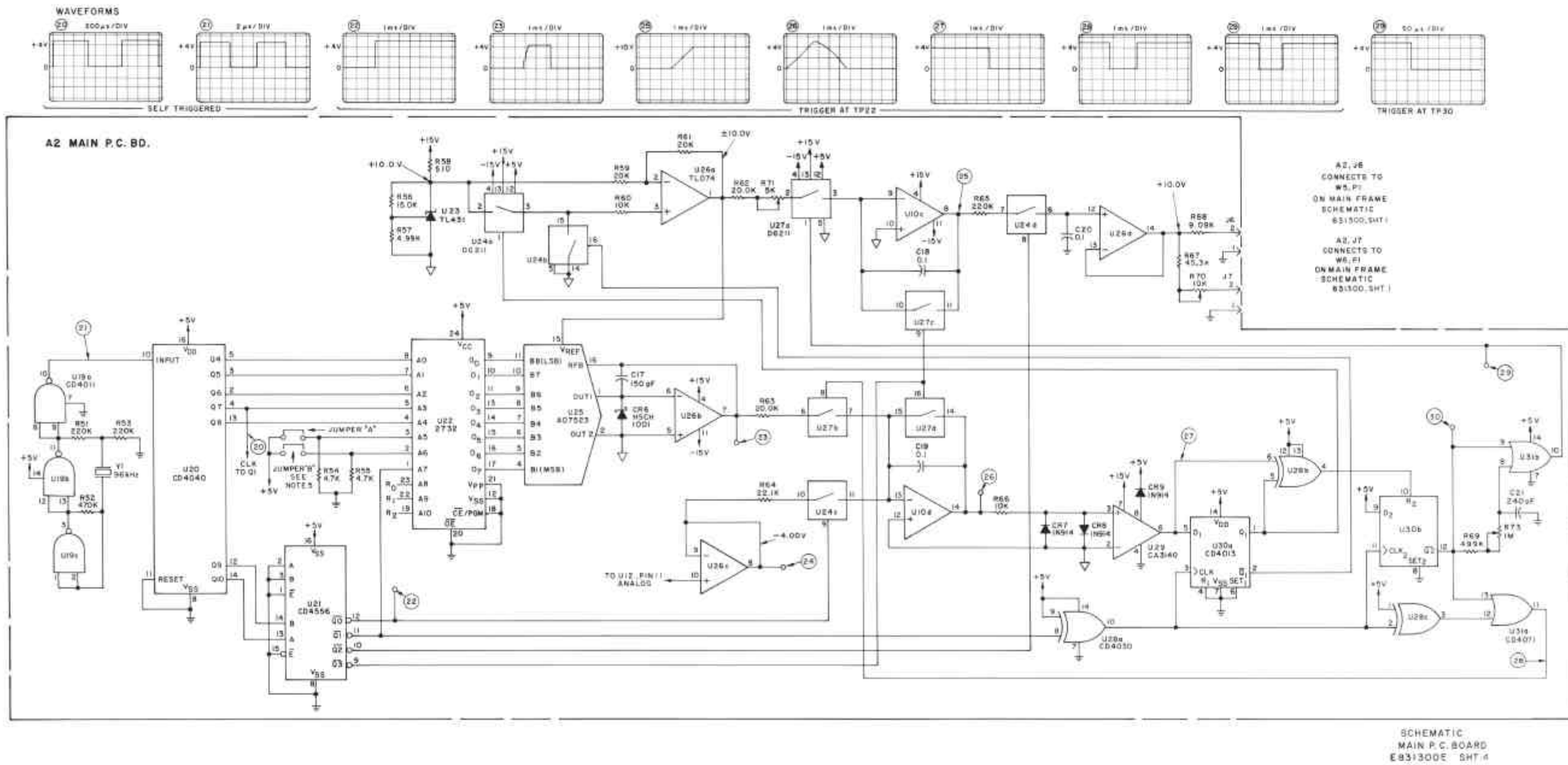
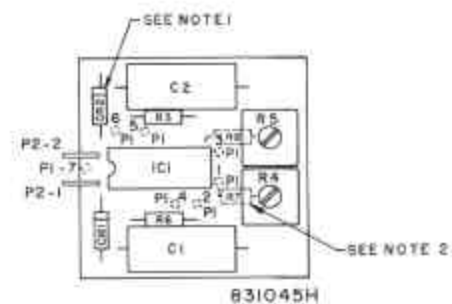
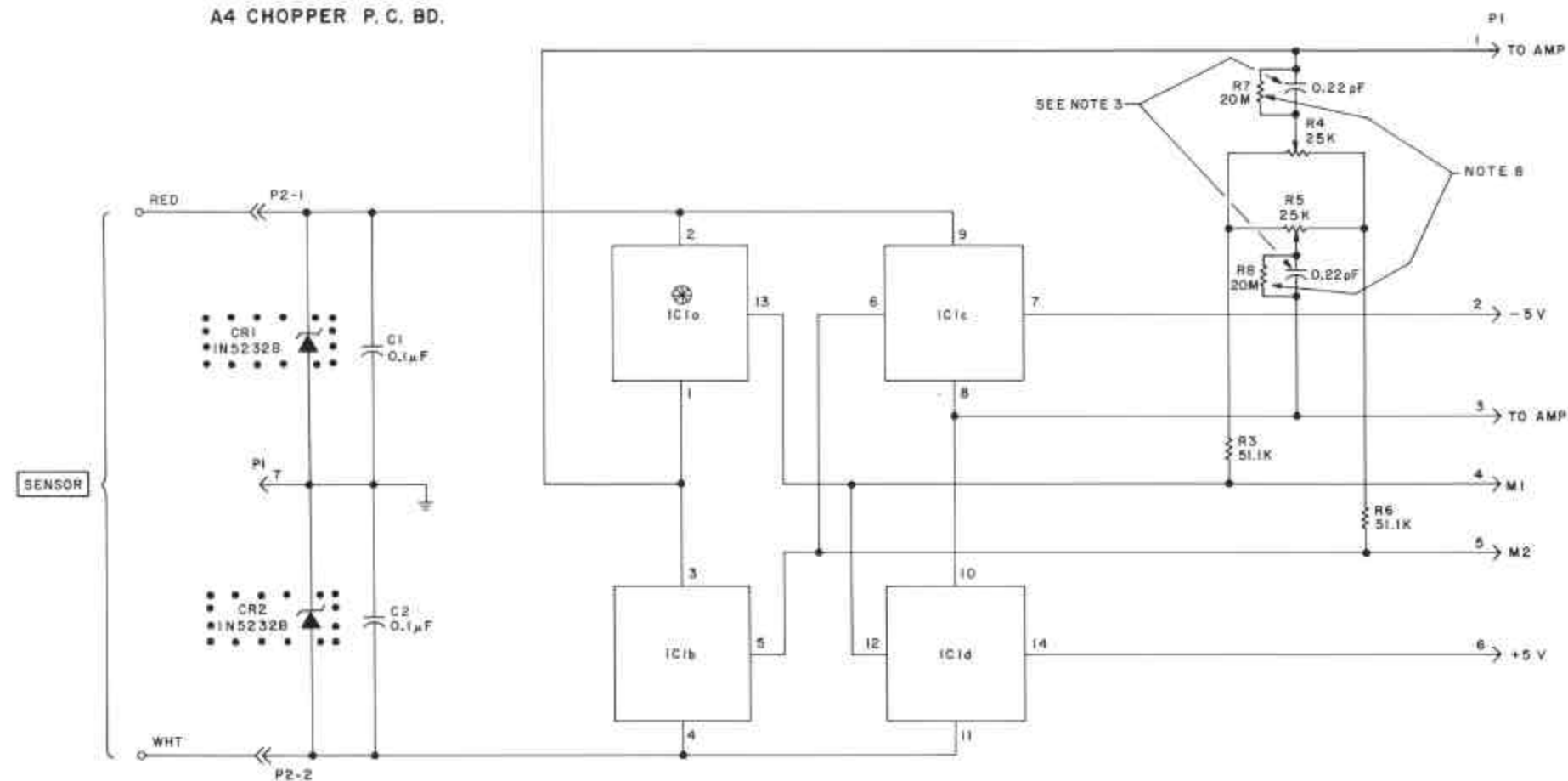

Figure 7-5. Main PC Board
Schematic Diagram
Sheet 2 of 2

A4 CHOPPER P. C. BD.



NOTE
1. CR1 AND CR2 USED ON 92E/EA-S5 ONLY.
2. R7 AND R8 USED WITH 4210-7E AND 4210-8E ONLY.



P1
CONNECTS TO
A6 J1
ON FRAME SCHEMATIC
B31271
SHT. 1 OF 7
AND
A6 J1
ON OPTION FRAME
SCHEMATIC
B31099
AND
A2 J2
ON FRAME SCHEMATIC
B31170
SHT. 1 OF 3

- NOTES:
1. RESISTANCE VALUES IN OHMS.
 2. SELECTED VALUE.
 3. CAPACITANCE IS PART OF P.C. BD. CIRCUITRY.
 4. EXTERNAL MARKING.
 5. LAST NUMBERS USED:
RB
 6. NUMBERS NOT USED:
R1, R2
 7. USED ON 92E-S5 ONLY.
 8. RES R7, R8 USED ONLY WITH 4210-7E AND 4210-8E SENSORS.

SCHEMATIC, CHOPPER P.C. BD.
D831271D SHT. 4 OF 9

Figure 7-6. Chopper PC Board
Schematic and Parts
Location Diagram

WARRANTY

Boonton Electronics (Boonton) warrants its products to the original Purchaser to be free from defects in material and workmanship for a period of one year from date of shipment for instrument, and for one year from date of shipment for probes, power sensors and accessories. Boonton further warrants that its instruments will perform within all current specifications under normal use and service for one year from date of shipment. These warranties do not cover active devices that have given normal service, sealed assemblies which have been opened or any item which has been repaired or altered without Boonton's authorization.

Boonton's warranties are limited to either the repair or replacement, at Boonton's option, of any product found to be defective under the terms of these warranties.

There will be no charge for parts and labor during the warranty period. The Purchaser shall prepay shipping charges to Boonton or its designated service facility and shall return the product in its original or an equivalent shipping container. Boonton or its designated service facility shall pay shipping charges to return the product to the Purchaser. The Purchaser shall pay all shipping charges, duties and taxes if a product is returned to Boonton from outside of the United States.

THE FOREGOING WARRANTIES ARE IN LIEU OF ALL OTHER WARRANTIES, EXPRESSED OR IMPLIED, INCLUDING, BUT NOT LIMITED TO, THE IMPLIED WARRANTIES OF MERCHANTABILITY AND FITNESS FOR A PARTICULAR PURPOSE. BE shall not be liable to any incidental or consequential damages, as defined in Section 2-715 of the Uniform Commercial Code, in connection with the products covered by the foregoing warranties.

BOONTON
