

- 1 Hz frequency resolution (Option 008)
- Low spurious and phase noise
- +20 dBm to -110 dBm calibrated output (Option 001)



HP 8360 Series Synthesized Sweepers

The HP 8360 series synthesized sweepers are the standard of excellence for applications requiring the high performance and accuracy of a synthesized source and the speed and versatility of a sweep oscillator.

Synthesized broadband frequency coverage and precise 1 Hz frequency resolution (Option 008) are generated by indirect synthesis, enabling the HP 8360 to achieve low single-sideband phase noise performance.

The HP 8360 delivers excellent harmonic performance with harmonics at least 50 dB below the carrier from 2.2 to 20 GHz, and at least 35 dB below the carrier above 20 GHz.

Pulse, Scan, Amplitude, and Frequency Modulation

High-performance pulse modulators with >80 dB on/off ratio, and rise/fall times < 10 ns (Option 006), make the HP 8360 suitable for the most demanding pulse modulation applications.

In addition to its linear AM mode (100%/V), the HP 8360 offers a scan modulation mode (10 dB/V). Both modes have dc-coupled amplitude modulation capability with a 3 dB bandwidth of 100 kHz, and 99.7% (50 dB) of modulation depth. Pulse and amplitude modulation capabilities can be used independently and simultaneously.

The HP 8360 also offers dc-coupled frequency modulation capabilities with rates up to 8 MHz.

Millimeter Signals

When the HP 8360 series is used to drive the HP 83550 series millimeter-wave modules, they provide millimeter test signals from 26.5 to 110 GHz. The source modules offer leveled high output power, full waveguide band coverage, and frequency accuracy and resolution proportional to the HP 8360 used.

The HP 83550 source modules can be driven directly by the HP 83623 and 83624 synthesized sweepers. Other HP 8360 models can drive the source modules through the HP 8349B amplifier.

Specification Summary

Frequency

- Range (by model):
- HP 83620A 10 MHz to 20 GHz
 - HP 83622A 2 to 20 GHz
 - HP 83623A 10 MHz to 20 GHz (high power)
 - HP 83624A 2 to 20 GHz (high power)
 - HP 83630A 10 MHz to 26.5 GHz
 - HP 83640A 10 MHz to 40 GHz
 - HP 83650A 10 MHz to 50 GHz

Resolution: 1 kHz standard, 1 Hz optional

Time base: Internal 10 MHz time base. Aging rate: less than 5×10^{-10} /day, 1×10^{-7} /year after 30-day warm-up.

RF Output

Range: +20 to -110 dBm with Opt 001 Resolution: 0.02 dB
Maximum Leveled Power (by model):

- | | | | |
|-----------|---------|-----------|----------|
| HP 83620A | +13 dBm | HP 83630A | +10 dBm |
| HP 83622A | +13 dBm | HP 83640A | +6 dBm |
| HP 83623A | +17 dBm | HP 83650A | +2.5 dBm |
| HP 83624A | +20 dBm | | |

RF Output Connector: 3.5 mm on 20 GHz models, 2.4 mm on 40 and 50 GHz models; nominal 50 Ω output impedance

Maximum leveled output power is reduced by 1.5 to 2.5 dB between .01 and 50 GHz.

- Pulse, amplitude, and frequency modulation
- Complete analog sweeper
- < -50 dBc harmonics 2.2 to 20 GHz

Spectral Purity

Harmonics and subharmonics:

- < -50 dBc at output frequencies < 20 GHz
- < -40 dBc at output frequencies < 40 GHz
- < -35 dBc at output frequencies > 40 GHz

Non-harmonically related spurious:

- < -60 dBc at output frequencies < 20 GHz
- < -52 dBc at output frequencies > 20 GHz

Single-sideband phase noise (dBc/1 Hz BW, CW mode):

Frequency range (GHz)	100 Hz	1 kHz	10 kHz	100 kHz
0.01 to 7.0	-70	-78	-86	-107
7.0 to 13.5	-64	-72	-80	-101
13.5 to 20.0	-60	-68	-76	-97
20.0 to 26.5	-58	-66	-74	-95
26.5 to 38.0	-54	-62	-70	-91
38.0 to 40.0	-54	-62	-70	-91
40.0 to 50.0	-52	-60	-68	-89

Modulation

Pulse modulation

On/off ratio: > 80 dB

Rise and fall times: < 25 ns (< 10 ns optional)

Minimum internally leveled RF pulse width: < 1 μ s

Minimum RF pulse width: < 50 ns (15 ns with Opt 006)

Scan and amplitude modulation

Rates (3dB BW): dc to 100 kHz

Depth: 0 to 90% (20 dB) and 0 to 99.7% (50 dB) above 10 Hz

Sensitivity: 100%/V and 10 dB/V

Frequency modulation

Locked mode

Modulation rate (3 dB BW, 500 kHz deviation): 100 kHz to 8 MHz

Maximum deviations: 8 MHz

Unlocked mode

Modulation rate (3 dB BW, 500 kHz deviation): dc to 8 MHz

Maximum deviations: At rates \leq 100 Hz: \pm 75 MHz

At rates > 100 Hz: \pm 8 MHz

Sensitivity: 1 MHz/V or 10 MHz/V, user-selectable

Internal Modulation Generator (Opt 002),

AM, FM

Waveforms: Sine, square, triangle, ramp, noise

Rate range: Sine: 1 Hz to 1 MHz

Square, triangle, ramp: 1 Hz to 100 kHz

Rate resolution: 1 Hz

Depth, deviation

Range and accuracy: Same as base instrument

Resolution: 0.1%

Pulse

Modes: Free-run, gated, triggered, delayed

Period range: 300 ns to 400 ms

Width range: 25 ns to 400 ms

Video delay

Internal sync pulse: 0 to 400 ms

Externally supplied sync pulse: 225 ns to 400 ms

Ordering Information

- HP 83620A Synthesized Sweeper
- HP 83622A Synthesized Sweeper
- HP 83623A Synthesized Sweeper
- HP 83624A Synthesized Sweeper
- HP 83630A Synthesized Sweeper
- HP 83640A Synthesized Sweeper
- HP 83650A Synthesized Sweeper
- Opt 001 Add Step Attenuator
- Opt 002 Internal Modulation Generator
- Opt 003 Delete Front Panel Keyboard/Display
- Opt 004 Rear Panel RF Output
- Opt 006 Fast Pulse Modulation
- Opt 008 1 Hz Frequency Resolution
- Opt 700 Mate System Compatibility
- Opt W30 Extended Repair Service (see page 588)

Dedicated HP 8510 Synthesized Sweepers

- HP 83621A Synthesized Source
- HP 83631A Synthesized Source
- HP 83651A Synthesized Source
- Opt W30 Extended Repair Service (see page 588)

SIGNAL SOURCES

HP 83550 Series Millimeter-Wave Source Modules

HP 83554A, 83555A, 83556A, 83557A, and 83558A

- 26.5 to 110 GHz frequency range
- Leveled high output power
- Can be driven by many HP microwave sources

- Source module remotable up to one meter length
- Low entry cost

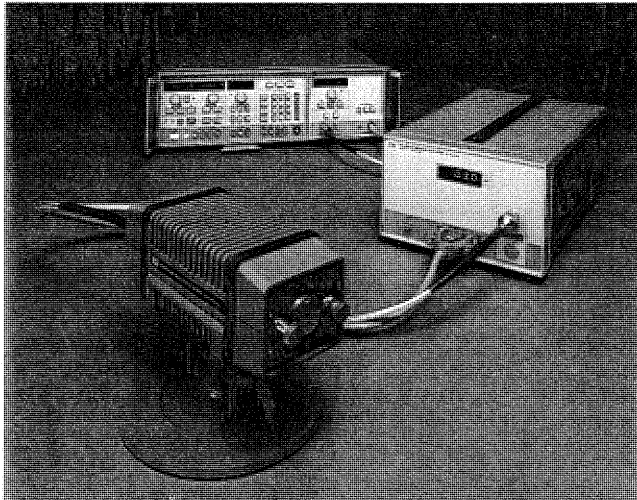

HP 83550 Series Millimeter-Wave Source Modules

The five HP 83550 series millimeter-wave source modules provide a simple approach to extend the frequency range of 11 to 20 GHz sources to cover 26.5 to 40 GHz (HP 83554A), 33 to 50 GHz (HP 83555A), 40 to 60 GHz (HP 83556A), 50 to 75 GHz (HP 83557A), and 75 to 110 GHz (HP 83558A) bands. The HP 83550 series source modules offer leveled high output power, full waveguide band frequency coverage, and the high frequency accuracy and resolution of the driving microwave source.

As shown in the figure in the right column, there are three basic ways of configuring a millimeter-wave source to best suit your specific needs. Your choice can range from a sophisticated synthesized sweeper (HP 83623A or HP 83624A) to a sweep oscillator (HP 8350B/8359x) with an HP 8349B amplifier.

Pulse, AM, and FM Modulation

The high-performance pulse modulators of the Hewlett-Packard synthesized sources offer >80 dB on/off ratio and <50 ns rise and fall times. Pulse amplitudes are leveled for pulse widths as narrow as 1 μ s.

The HP 8340B/8341B also feature dc-coupled AM with a 3 dB bandwidth of 100 kHz. Pulse and amplitude modulation can be used to simultaneously simulate antenna scan patterns.

FM rates between 100 Hz and 10 MHz may be applied to the HP 8673B/C/D synthesizer input to achieve deviations up to 20 MHz (HP 83554A) and 30 MHz (HP 83555A, 83556A), 40 MHz (HP 83557A), and 60 MHz (HP 83558A) at millimeter-wave frequencies.

High Output Power

Leveled output power from the source modules is rated at +8 dBm for the HP 83554A, +3 dBm for the HP 83555A, +3 dBm for the HP 83556A, +3 dBm for the HP 83557A, and 0 dBm for the HP 83558A. This high output power can permit the source module to serve as a mixer LO in some applications and also expands the available dynamic range in frequency response measurements.

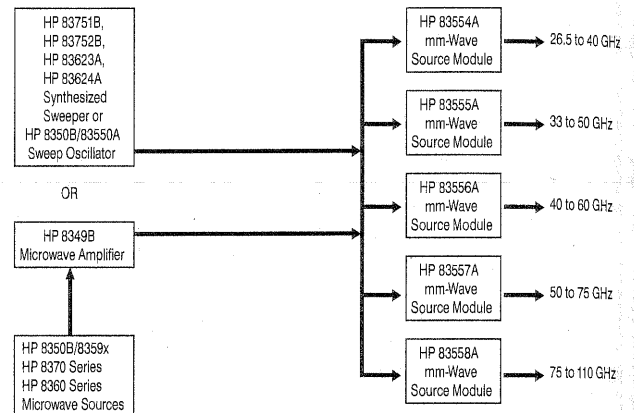

All at a Lower Cost

The HP 83550 series source modules combine performance and quality with a low cost of entry. This is possible because the source modules are backward-compatible with existing HP microwave sources. Thus you can generate a full waveguide band of millimeter-wave frequencies for just the cost of a source module and an HP 8349B amplifier (where required). Also, the cost of ownership is reduced even further by the two-year warranty on the microcircuits of the HP 83550 series source modules and the HP 8349B microwave amplifier.

HP 83554A Output Characteristics

Characteristics	HP 8350B/83550A	HP 8350B/ 83590 Series/8349B	HP 8360 Series/8349B, HP 83623A, 83624A, 83650A	HP 8370 Series/8349B, HP 83751B, 83752B
Maximum leveled power (25° ± 5° C)	+8 dBm	+8 dBm	+8 dBm	+8 dBm
Minimum settable power:	-5 dBm	-5 dBm	-5 dBm	-5 dBm
Power level accuracy ² (25° ± 5° C)	±2.00 dB	±2.00 dB	±2.00 dB	±2.00 dB
Power flatness (at max leveled power)	±1.50 dB	±1.50 dB ³	±1.50 dB ³	±1.50 dB ³
Source output SWR	<2.0	<2.0	<2.0	<2.0
Spurious signals ⁴				
Harmonically related spurious:				
26.5 to 26.7 GHz	< -25 dBc	< -25 dBc	< -25 dBc	< -25 dBc
26.7 to 40.0 GHz	< -50 dBc	< -20 dBc ⁴	< -40 dBc	< -20 dBc ⁵