

Specifications

Input			
Parameter	Voltage	Current (5A input element)	Current (50A input element)
Input type	Floating input Resistive potential division method	Shunt input method	
Rated value (range-value)	1.5/3/6/10/15/30/60/100/150/300/600/1000V	Direct input: 10m/20m/50m/100m/200m/500m/1/2/5A External input: 50m/100m/250m/500m/1/2.5/5/10V	Direct input: 1/2/5/10/20/50A External input: 50m/100m/250m/500m/1/2.5/5/10V
Instrument loss (input resistance)	Approximately 2MΩ	Direct input: Approximately 100mΩ + Approximately 0.07μH External input: Approximately 100kΩ	Direct input: Approximately 2mΩ + Approximately 0.07μH External input: Approximately 100kΩ
Instantaneous maximum allowed input (1 cycle, for 20 ms)	Peak voltage of 4 kV or rms of 1.5 kV (whichever is lower)	Peak current of 30 A or rms of 15 A (whichever is lower) External input: Peak not to exceed 10 times range-value	Peak current of 450 A or rms of 300 A (whichever is lower) External input: Peak not to exceed 10 times range-value
Continuous maximum allowed input	Peak voltage of 1.5 kV or rms of 1 kV (whichever is lower)	Peak current of 10 A or rms of 7 A (whichever is lower) External input: Peak not to exceed 5 times range-value	Peak current of 150 A or rms of 50 A (whichever is lower) External input: Peak not to exceed 5 times range-value
Continuous maximum in-phase voltage (50/60 Hz)	600 Vrms CATII		
Common mode rejection ratio (600 Vrms)	(with voltage input terminals shorted and current input terminals open) 50/60 Hz: ±0.01% of rng or less (±(0.01 × 15/(rated value of rng))% of rng or less for 10-V rng or less). Up to 100 kHz: Reference value ±(0.1 × f% of rng) or less, (±(0.1 × f × 15/(rated value of rng))% of rng or less for 10-V rng or less), but no less than 0.01% ; frequency unit: kHz		
Input terminal type	Plug-in terminal (safety terminal)	Direct input: Large binding post (frequency band of assured accuracy: up to 1 MHz for the 5 A terminal, up to 100 kHz for the 50 A terminal). Current sensor input: BNC connector (frequency band of assured accuracy: up to 500 kHz).	
A/D converter	Voltage/current input simultaneous conversion, 16-bit resolution, conversion speed of approximately 5 μsec		
Switching range-value	Range-value can be set independently for each element, through manual setting, automatic setting, or online setting		
Auto-range function	Increasing range-value: Range-value is increased when rms exceeds 110% of rated value or peak value exceeds approximately 330% of rated value. Decreasing range-value: Range-value is decreased when peak is 300% or less of lower range-value while rms is 30% or less of rated value.		

Measurement Functions

Method	Digital multiplication method		
Crest factor	3 (when rated value of the measurement range is input) However, it is 2 for the 1000 V range.		
Temperature: 23 ± 3°C Humidity: 30 to 75%RH Input waveform: Sinewave In-phase voltage: 0 V Line filter: OFF Power factor: cosφ = 1 Specified following zero level correction or range-value change after warmup period ends. 3-month accuracy Unit for f in accuracy calculation equation: kHz	Frequency	Voltage/Current	Power
	DC	0.1% of rdg + 0.2% of rng	0.1% of rdg + 0.2% of rng
	0.5 Hz ≤ f < 10 Hz	0.1% of rdg + 0.2% of rng	0.2% of rdg + 0.3% of rng
	10 Hz ≤ f < 45 Hz	0.1% of rdg + 0.1% of rng	0.1% of rdg + 0.2% of rng
	45 Hz ≤ f ≤ 66 Hz	0.1% of rdg + 0.05% of rng	0.1% of rdg + 0.05% of rng
	66 Hz < f ≤ 1 kHz	0.1% of rdg + 0.1% of rng (Voltage, 5A input element current direct input and external input) 0.2% of rdg + 0.1% of rng (50A input element current direct input)	0.2% of rdg + 0.1% of rng
	1 kHz < f ≤ 50 kHz	0.3% of rdg + 0.1% of rng (Voltage, 5A input element current direct input) (0.015 × f + 0.3%) of rdg + 0.1% of rng (External input) (0.1 × f + 0.2%) of rdg + 0.1% of rng (50A input element current direct input)	0.3% of rdg + 0.2% of rng (Voltage, 5A input element current direct input) (0.02 × f + 0.3%) of rdg + 0.2% of rng (External input) (0.1 × f + 0.2%) of rdg + 0.2% of rng (50A input element current direct input)
	50 kHz < f ≤ 100 kHz	0.6% of rdg + 0.2% of rng (Voltage, 5A input element current direct input) (0.009 × f + 0.6%) of rdg + 0.2% of rng (External input) (0.1 × f + 0.2%) of rdg + 0.2% of rng (50A input element current direct input)	0.7% of rdg + 0.3% of rng (5A input element current direct input) (0.009 × f + 0.9%) of rdg + 0.3% of rng (External input) (0.3 × f - 9.5%) of rdg + 0.3% of rng (50A input element current direct input)
	100 kHz < f ≤ 500 kHz	0.006% of rdg + 0.5% of rng (Voltage, 5A input element current direct input) (0.03 × f - 1.5%) of rdg + 0.5% of rng (External input)	0.008% of rdg + 1% of rng (5A input element current direct input) (0.06 × f - 4%) of rdg + 1% of rng (External input)
	500 kHz < f ≤ 1 MHz	(0.022 × f - 8) of rdg + 1% of rng (Voltage, 5A input element current direct input)	(0.048 × f - 20) of rdg + 2% of rng (5A input element current direct input)
	Power factor effect φ: Voltage and current phase angle	When cos φ = 0, 45 Hz to 66 Hz: 0.15% of apparent power reading is added to the above power accuracy. For other frequencies: Reference value For 5 A input element current direct input, add (0.15 + 0.05 × f%) of apparent power reading to the above accuracy. For 50 A input element current direct input, add (0.15 + 0.3 × f%) of apparent power reading to the above accuracy. For external input, add (0.15 + 0.1 × f%) of apparent power reading to the above accuracy. When 0 < cos φ < 1, add (tan φ × (influence of power factor = 0)) of power reading.	
Effective input range	Voltage, current: Rms and AC: 1% to 110% of rated range-value, DC: 0% to ±110% of rated range-value, Mean: 10% to 110% of rated range-value Power: DC measurement: 0% to ±110% of rated range-value, AC measurement: Up to ±110% of power range-value, with voltage and current within 1% to 110% of rated range-value (Sync source signal level must be at least 10% of rated range-value) Effective input is in the range up to 1000V at Voltage, 5A at 5A input element, 50A at 50A input element and 10V at External input.		
One-year accuracy	1.5 times tolerance for 3-month accuracy reading		
Line filter function	Measurement can be made with a line filter inserted in the input circuit. Cutoff frequency (fc): 500 Hz or 5.5 kHz		
Line filter on accuracy	Cut-off frequency of 500 Hz: Voltage, current: Add 0.2% of rdg in range of 45 to 66 Hz. Under 45 Hz, add 0.5% of rdg. Power: Add 0.3% of rdg in range of 45 to 66 Hz. Under 45 Hz, add 1% of rdg. Cutoff frequency of 5.5 kHz: Voltage, current: Add 0.2% of rdg under 66 Hz. At 66 Hz to 500 Hz, add 0.5% of rdg. Power: Add 0.3% of rdg under 66 Hz. At 66 Hz to 500 Hz, add 1% of rdg.		
Temperature coefficient	±0.03% of rdg/°C at 5 to 20°C and 26 to 40°C		
Conditions for detecting lead and lag	Lead and lag are detected correctly when the voltage and current signals are both sine waves, the amplitude is greater than or equal to 50% of the measurement range, the frequency is between 20 Hz to 10 kHz, and the phase difference is greater than or equal to ±5°.		
Measurement lower limit frequency	Data update rate	50 msec	100 msec
	Measurement lower limit frequency	45 Hz	25 Hz
		200 msec	15 Hz
		500 msec	5 Hz
		1 sec	2.5 Hz
		2 sec	1.5 Hz
		5 sec	0.5 Hz

Current and power DC accuracy (5 A input element) ----Add 20 μA to current and 20 μA × (voltage reading) to power
 Current and power DC accuracy (50 A input element) ----Add 1 mA to current and 1 mA × (voltage reading) to power
 External input ----Add (0.05/scaling value) A to current and (0.05/scaling value) A × (voltage reading) to power
 Zero level correction or as a zero level correction in current and power DC accuracy relating to temperature changes following range-value changes, add 10 μA/°C to current and add (10 μA × voltage reading) /°C to power for the 5 A input element. For the 50 A input element, add 1 mA/°C to current and add (1 mA × voltage reading) /°C to power. For external input, add (0.05/scaling value) A/°C to current and add {(0.05/scaling value) A × (voltage reading) /°C} to power.
 Voltage rms, mean, AC ---- Add 5 mV.
 Current rms, mean, AC ----Accuracy figures are specified with line filter turned ON for 2 mA or less on a 5 A input element, for 200 mA or less on a 50 A input element, for 10/(scaling value) A or less on an external input.
 Add (0.006 × I²)% at 5 A input element.
 Add (0.00006 × I²)% at 50 A input element.
 Add 0.1% of range if the display updating period is 50 msec.
 All accuracy of 0.5 Hz to 10 Hz: Reference values
 Voltage ---- Reference values in cases where f(Hz) × voltage(V) > 2.2 × 10⁷ at 100 kHz or higher.
 Current ---- Reference values for 20 AAC or higher (except for range of 50 Hz to 400 Hz) or higher
 For currents less than 5 mA with frequencies above 1 kHz, the current accuracy and the power accuracy figures are the reference values.
 Add 20% of rng to the accuracy above for the accuracy of the waveform display data, voltage peak (Upk), and current peak (Ipk) in the range up to 1 MHz. (Reference Value) rdg: reading, rng: range

Specifications

Calculation Functions

		Single-phase three-wire	Three-phase three-wire (2 voltage, 2 current)	Three-phase three-wire (3 voltage, 3 current)	Three-phase four-wire
Voltage ΣU		(U1+U2)/2		(U1+U2+U3)/3	
Current ΣI		(I1+I2)/2		(I1+I2+I3)/3	
Active power ΣP		P1+P2			P1+P2+P3
Reactive power $S, \Sigma Q$	Normal measurement	$Q_i = \sqrt{(S^2 - P^2)}$			
	Harmonic measurement	Q1+Q2			Q1+Q2+Q3
Apparent power $S, \Sigma S$	Normal measurement	$S_i = U_i \times I_i$	S1+S2	$\frac{\sqrt{3}}{2} (S1+S2)$	$\frac{\sqrt{3}}{2} (S1+S2+S3)$
	Harmonic measurement	$S_i = \sqrt{(P_i^2 + Q_i^2)}$	$\sqrt{(\Sigma P^2 + \Sigma Q^2)}$		
Power factor $\lambda, \Sigma \lambda$	Power factor $\lambda, \Sigma \lambda$	$\lambda_i = P_i / S_i$	$\Sigma P / \Sigma S$		
Phase angle $\phi, \Sigma \phi$	Phase angle $\phi, \Sigma \phi$	$\phi_i = \cos^{-1}(P_i / S_i)$	$\phi_i = \cos^{-1}(\Sigma P / \Sigma S)$		
Calculation precision (of calculated values relative to measured values)		Apparent power (S) and reactive power (Q): $\pm 0.001\%$ of power range-value Power factor (λ): ± 0.0001 Phase angle (ϕ): $\pm 0.005^\circ$ relative to calculation from power factor			

Note 1: Apparent power (S), reactive power (Q), power factor (λ), and phase angle (ϕ) for this equipment are calculated from active power. (However, reactive power during harmonic measurement is the sum of every order.) Therefore, in the case of distorted-wave input, these values may be different from those of other instruments based on different measurement principles.

Note 2: If the phase angle display is 0 to 360, there is no accuracy specification for 0 and 180 \pm 5 degrees.

Other parameters (during normal measurement)

Upk, IpK (peak value), CF (crest factor), FF (form factor), |Z| (impedance), Rs and Rp (resistance), Xs and Xp (reactance), η and $1/\eta$ (efficiency), Pc (Corrected Power), F1 to F4 (user-defined functions), delta calculations (three-phase three-wire, 3V3A conversion, Y-A conversion, A-Y conversion)

Wiring settings: Settings can be divided into three groups (ΣA , ΣB , and ΣC).

Each group is selected from the following: 1P2W (single-phase two-wire, one element used), 1P3W (single-phase three-wire, two elements used), 3P3W (three-phase three-wire, two elements used), 3V3A (three-phase three-wire, three elements used), 3P4W (three-phase four-wire, three elements used).

Display Functions

Display: 6.4-inch color TFT LCD
 Pixels in full screen: 640 x 480 (The LCD unit may contain defects of approximately 0.02% in the pixels of the full screen)

Display type

Numerical values: Normal measurement: 4/8/16/42/78/ALL

Harmonic measurement: 4/8/16/Single List/Dual List

Waveforms: Single/Dual/Triad/Quad

Vector: Phase diagram for first-order components in harmonic measurement

Bar: Bar graph up to upper limit of analyzed orders in harmonic measurement

Trend display: Trend display of measured/calculated values

Data updating rate: Selected from 50msec/100msec/200msec/500msec/1sec/2sec/5sec. (waveform OFF)
 (Add approximately 500msec when the waveform data acquisition is ON.) The display update cycle is maximum 100msec when the waveform data acquisition is OFF and only in the Numeric display (16 or less value). It is 200msec or more at the other data update rates.

Internal memory: Approximately 11 MB

Response type: Up to data updating rate x 2 (with waveform acquisition off)

Display scaling function: PT ratio, CT ratio, and power scaling factor can be scaled.

Averaging functions: Normal measurement

Methods: Exponential average or simple moving average

Exponential average: Attenuation constant of 2, 4, 8, 16, 32, or 64
 Moving average: Number of averages (N) set to 8, 16, 32, 64, 128, or 256

Harmonic measurement
 When using an exponential average, the attenuation constant is 5.625 if the frequency of the PLL synchronization source is 55 Hz or greater but less than 75 Hz; otherwise, the attenuation constant is 4.6875. (When data length = 8192)

Display resolution: U, I, P: During rated range-value input, the decimal place and the counting unit are set so that the display does not exceed a count value of 60,000. ΣU , ΣI , ΣP : The decimal place and the counting unit are the same as for the maximum range-value of the calculated element.

Frequency Measurement Functions

Measurement input: Select three of the following: U1, I1, U2, I2, U3, I3, U4, I4, U5, I5, U6, I6

Measurement method: Reciprocal method

Frequency range: Data updating rate
 50 msec: 45 Hz $\leq f \leq$ 1 MHz
 100 msec: 25 Hz $\leq f \leq$ 1 MHz
 200 msec: 15 Hz $\leq f \leq$ 500 kHz
 500 msec: 5 Hz $\leq f \leq$ 200 kHz
 1 sec: 2.5 Hz $\leq f \leq$ 100 kHz
 2 sec: 1.5 Hz $\leq f \leq$ 50 kHz
 5 sec: 0.5 Hz $\leq f \leq$ 20 kHz

Accuracy

$\pm(0.05\%$ of reading + 1 digit)

Note: Within accuracy-assured range $\pm(0.05\%$ of rdg + 1 digit) for the measurement function parameters. Input signal level is greater than or equal to 0.6 V (voltage input), 25 mV (external input), 5 mA (5-A input element), or 150 mA (50-A input element) and the signal is greater than or equal to 30% (from 0.5 Hz to less than 440 Hz, with zero crossing filter ON), 10% (from 440 Hz to 500 kHz), or 30% (from more than 500 kHz to 1 MHz) of the measurement range.

Integration Functions

The integrating functions do not work during waveform acquisition or in harmonic analysis mode ON.

Measured parameters:

Power (Wp), positive-only power (+Wp), negative-only power (-Wp), current (q), positive-only current (+q), negative-only current (-q) (For current integration, select only one of the following for each element: rms, mean, DC, AC.), time (Time)
 Standard integration mode (timer mode)
 Continuous integration mode (repeat mode)
 Manual integration mode

Mode

Individual element integration

Integration can be started/stopped element by element using GP-IB or serial (RS-232) communications. Integration can be stopped automatically according to a timer setting.

Timer

Setting range: 0000h00min00sec to 10000h00min00sec

Count overflow

If the integration value exceeds ± 999999 MWh(MAh), the elapsed time is saved and the operation is stopped.

Accuracy

$\pm(\text{unit accuracy} + 0.05\%$ of rdg)

Timer accuracy

$\pm 0.02\%$

Harmonic Measurement Functions

Measurements

Select one of the following: ΣA , ΣB , ΣC

Method

PLL synchronization or external sampling clock

Measurement frequency range

PLL synchronization: Synchronization source fundamental frequency of 10 Hz to 1 kHz
 External sampling clock: Fundamental wave of 0.5 Hz to 100 Hz (Input 2048 times the fundamental frequency. The waveform is a square wave with a duty cycle of 50% at the TTL level.)

Analyzed parameters

For each order: U, I, P, S, Q, λ , $\phi(U-I)$, $\phi(U)$, $\phi(I)$ (phase difference of harmonic component relative to fundamental wave), |Z|, Rs, Rp, Xs, Xp
 Total: U, I, P, S, Q, λ , ϕ
 Σ calculation of fundamental wave and total: U, I, P, S, Q, and λ

For each order: Harmonic content of U, I, and P
 THD of U, I, and P

UTHF (voltage telephone harmonic factor), ITHF (current telephone harmonic factor), UTIF (voltage telephone influence factor), ITIF (current telephone influence factor), HVF (harmonic voltage factor), HIF (harmonic current factor)

FFT data length

8192, 4096, or 2048

FFT processed word length

32 bits

Window function

Rectangular

Anti-aliasing filter

Set by line filter ($f_c = 5.5$ kHz)

PLL synchronization

Fundamental frequency (Hz)	Sampling frequency	Window width relative to FFT data length (number of fundamental wave cycles)		Maximum analyzed orders
		8192	4096	2048
$10 \leq f < 20$	$f \times 2048$	4	2	1
$20 \leq f < 40$	$f \times 1024$	8	4	2
$40 \leq f < 75$	$f \times 512$	16	8	4
$75 \leq f < 150$	$f \times 256$	32	16	8
$150 \leq f < 440$	$f \times 128$	64	32	16
$440 \leq f \leq 1000$	$f \times 64$	128	64	32

External sampling clock

Fundamental frequency (Hz)	Sampling frequency	Window width relative to FFT data length (number of fundamental wave cycles)		Maximum analyzed orders
		8192	4096	2048
$0.5 \leq f \leq 100$	$f \times 2048$	4	2	1

However, it is $1 \leq f \leq 100$ when the FFT data length is 8192

Accuracy (Line filter 5.5 kHz ON)

	Voltage/Current	Power
$0.5 \text{ Hz} \leq f < 10 \text{ Hz}$	0.4% of rdg + 0.2% of rng	0.7% of rdg + 0.3% of rng
$10 \text{ Hz} \leq f < 45 \text{ Hz}$	0.4% of rdg + 0.1% of rng	0.6% of rdg + 0.2% of rng
$45 \text{ Hz} \leq f \leq 66 \text{ Hz}$	0.3% of rdg + 0.05% of rng	0.4% of rdg + 0.05% of rng
$66 \text{ Hz} < f \leq 1 \text{ kHz}$	1% of rdg + 0.1% of rng	1.5% of rdg + 0.1% of rng
$1 \text{ kHz} < f \leq 2.5 \text{ kHz}$	2% of rdg + 0.1% of rng	-----

Line filter OFF

During nth-order component input, add $\{(n/(m+1))/50\}$ % of the nth-order reading to (n-m)th order and (n+m)th order.
 For normal measurement accuracy, during nth-order component input, add $\{(n/(m+1))/50\}$ % of the nth-order reading to (n-m)th order and (n+m)th order.
 Add $(n/500)$ % of the nth-order reading to the nth-order component.

Motor Evaluation Functions (optional)

The motor evaluation functions do not work in harmonic measurement mode.
 Calculated parameters Torque, rpms, mechanical power, synchronization speed, slip, motor efficiency, total efficiency

Measured parameters

Analog input for calculating torque and rpms	
Input resistance	Approximately 1M Ω
Accuracy	$\pm(0.1\%$ of rdg + 0.2% of rng)
Input range-values	1/2/5/10/20 V
Effective input range	Up to $\pm 110\%$ of range-value
Temperature coefficient	$\pm 0.03\%$ of rng/ $^{\circ}$ C
Pulse input for rpm calculation	
Input resistance	Approximately 1M Ω
Accuracy	$\pm 0.05\%$ of rdg + 1 mHz + 1 digit
Input range	± 5 Vpk
Effective amplitude	1 Vp-p or higher
Input waveform	50% duty ratio rectangular wave
Frequency measurement range	2 Hz to 200 kHz

D/A Output (optional)

Number of outputs 30 parameters (each channel can be set separately)
 Accuracy \pm (display accuracy + 0.2% of F.S.)
 Maximum output current ± 0.1 mA
 Temperature coefficient $\pm 0.05\%$ of F.S./ $^{\circ}$ C
 Output format
 Frequency

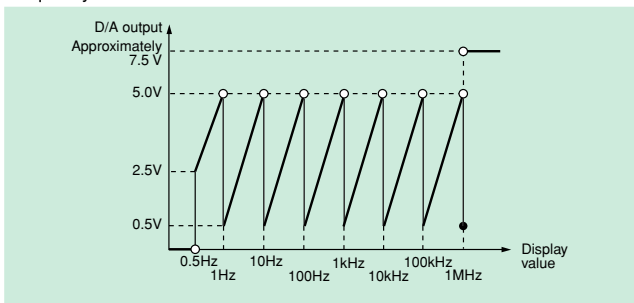

Integrated values

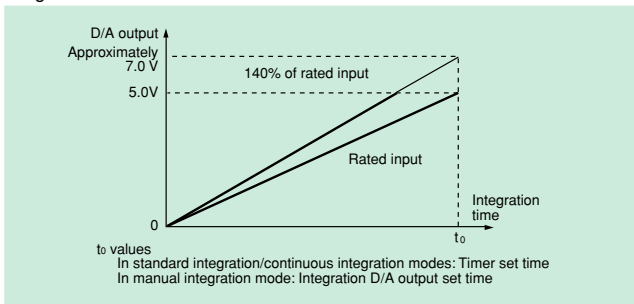

Other parameters

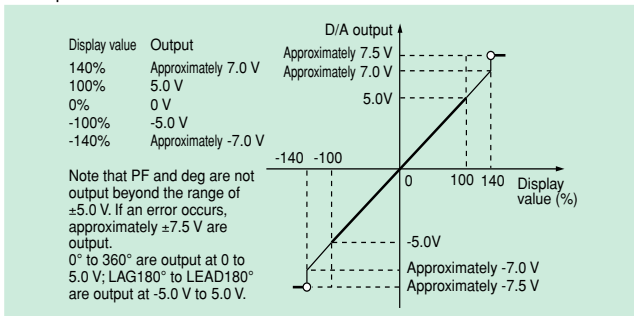

Waveform Display Functions

Triggers	Auto/Normal
Mode	Edge
Type	Edge
Source	U1, I1, U2, I2, U3, I3, U4, I4, U5, I5, U6, I6, external
Slope	Rising/falling/both
Position	0% (fixed)
Sample rate	Approximately 200 kHz
Time/Div	0.5 msec to 500 msec (not to exceed 1/10 of display updating period)
Vertical zoom	0.1 to 100 times
Data memory size	1 kW (Peak to peak compression data)
The frequency that allows displaying of waveforms is up to approximately 10 kHz.	

Built-in Printer (optional)

Printing method	Thermal line-dot
Dot density	8 dots/mm
Paper width	80 mm
Effective recording width	72 mm
Recorded information	Screenshots, list of measured values, harmonic bar graph printouts, settings

Ethernet (optional)

Transmission method	Ethernet (10BASE-T)
Supported services	FTP server, FTP client, LPR (network printing), SMTP (automatic mail transfer), DHCP, DNS
Electrical and mechanical specifications	As per IEEE802.3
Connector	RJ-45 connector

Built-in Hard Drive (optional)

Capacity	10 GB (2 GBx5) IBM format
SCSI ID	4 (fixed)

External I/O

EXT CLK	(Sync source during normal measurement, PLL source or external sampling clock during harmonic analysis)
Connector	BNC
Input voltage	TTL level
	EXT MEAS.START (external measurement start I/O), EXT MEAS.STOP (external measurement stop I/O)
Connector	BNC
Synchronized measurement	Connect the EXT MEAS.START terminal of the master unit with the EXT MEAS.START terminal of the slave unit, and connect the EXT MEAS.STOP terminal of the master unit with the EXT MEAS.STOP terminal of the slave unit.
Internal floppy drive	
Size	3.5-inch
Format	1.44 MB
Communication functions	
GP-IB or serial (RS-232)	provided as a standard function.
GP-IB interface	Electrical and mechanical specifications As per IEEE St'd 488-1978 Functional specifications SH1, AH1, T6, L4, SR1, RL1, PR0, DC1, DT0, C0 Protocol: As per IEEE St'd 488.2 1992
Serial (RS-232) interface	
Connector	D-Sub 9-pin
Specification	EIA-574 (specifications for 9-pin interface in EIA-232 (RS-232) standard)
Transfer rate	1200, 2400, 4800, 9600, 19200 bps
VGA video output	
Connector type	D-Sub 15-pin (VGA VIDEO OUT)
Output format	VGA-compatible
SCSI interface (optional)	
Specification	SCSI (Small Computer System Interface) ANSI X3.131-1986
Connector	D-sub half-pitch 50-pin (pin type)
Connector pin assignments	Unbalanced (single-end), internal terminator

Specifications

General Specifications

Safety standard*1	Complying standard EN61010-1 Overvoltage category (Installation category) II*2 Pollution degree 2 *3
Emission *1	Complying standard EN61326 Class A EN61000-3-2 EN61000-3-3 AS/NZS 2064 Class A EN61326 Annex A*4
Immunity *1	Complying standard
Warmup time	Approximately 1 hour
Operating temperature and humidity ranges	5 to 40°C, 20 to 80%RH when not using the printer, 5 to 40°C, 35 to 80%RH when using the printer. (no condensation)
Storage temperature	-25 to 60°C (no condensation)
Operating elevation	2000 meters or less
Insulating resistance	50 MΩ or higher at 500 VDC Between casing and power plug Between voltage input terminals (ganged) and casing Between current input terminals (ganged) and casing Between voltage input terminals (ganged) and current input terminals (ganged) Between input terminals of each element. Between torque/speed input terminals (ganged) and casing Between torque input terminals (ganged) and speed input terminals (ganged) Between input terminals of each element.
Withstand voltage	1500 VAC for one minute at 50/60 Hz Between casing and power plug 3700 VAC for one minute at 50/60 Hz Between voltage input terminals (ganged) and casing Between current input terminals (ganged) and casing Between voltage input terminals (ganged) and current input terminals (ganged) Between input terminals of each element.
Rated supply voltage	100 to 120 VAC, 200 to 240 VAC (switches automatically)
Allowed supply voltage fluctuation range	90 to 132 VAC, 180 to 264 VAC
Rated supply frequency	50/60 Hz
Allowed supply frequency fluctuation range	48 to 63 Hz
Consumed power	Maximum 150 VA (when using internal printer)
External dimensions	Approximately 426 mm (W) × 177 mm (H) × 400 mm (D) (excluding protrusions)
Weight	Approximately 15 kg (main unit with 6 input elements and options installed)

- *1 Emission, immunity and safety standards apply to products having the CE Mark. For all other products, please contact your nearest YOKOGAWA representative as listed on the back cover of this manual.
- *2 Overvoltage Categories define transient overvoltage levels, including impulse withstand voltage levels. Overvoltage Category II: Applies to equipment supplied with electricity from fixed installations like a distribution board.
- *3 Pollution Degree: Applies to closed atmospheres (with no, or only dry, non-conductive pollution).
Pollution Degree 2: Applies to normal indoor atmospheres (with only non-conductive pollution).
- *4 Annex A (normative): Immunity test requirements for equipment intended for use in industrial locations.

Exterior (WT1600)

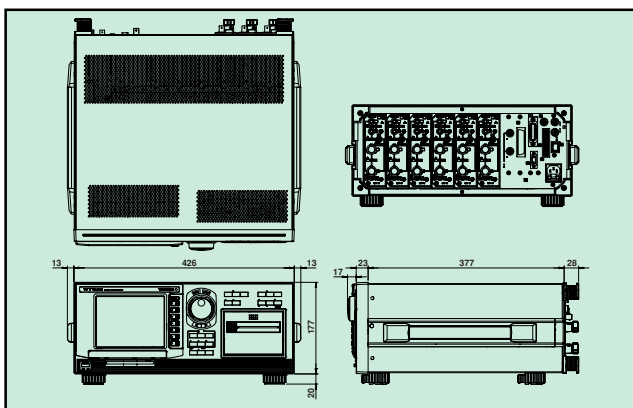

The TCP/IP software used in this product and the documentation for that TCP/IP software are based in part on BSD Networking Software, Release 1 licensed from The Regents of the University of California.

Model and Suffix Codes

Model	Suffix codes	Description				
760101		WT1600 digital power meter main unit				
Element types and quantities	Element Number					
	1	2	3	4	5	6
	-01	50				
	-02	50	50			
	-03	50	50	50		
	-04	50	50	50	50	
	-05	50	50	50	50	50
	-06	50	50	50	50	50
	-10	5				
	-11	5	50			
	-12	5	50	50		
	-13	5	50	50	50	
	-14	5	50	50	50	50
	-15	5	50	50	50	50
	-20	5	5			
	-21	5	5	50		
	-22	5	5	50	50	
	-23	5	5	50	50	50
	-24	5	5	50	50	50
	-30	5	5	5		
	-31	5	5	5	50	
	-32	5	5	5	50	50
	-33	5	5	5	50	50
	-40	5	5	5	5	
-41	5	5	5	5	50	
-42	5	5	5	5	50	
-50	5	5	5	5	5	
-51	5	5	5	5	5	
-60	5	5	5	5	5	
Communication functions	-C1	GP-IB				
	-C2	Serial (RS-232)				
Power cord	-D	UL/CSA Standard				
	-F	VDE Standard				
	-R	SAA Standard				
	-Q	BS Standard				
Option specifications	/B5	Internal printer				
	/C7	SCSI interface				
	/C10	Ethernet, HDD, SCSI				
	/DA	30-channel DA output				
	/MTR	Motor evaluation function				

- * The WT1600 unit cannot be purchased without any elements. Select an element type (5 A or 50 A) and quantity.
- Note: In order to add elements and options after the WT1600 has been delivered, the WT1600 must be modified at the factory. Be aware of this in making your product selections. For further details, see Yokogawa's home page or contact our sales office.

Accessories (sold separately)

Product	Model/part number	Description	Order quantity
Rack mounting kit	751535-E4	For EIA	1
Rack mounting kit	751535-J4	For JIS	1
BNC cable	366924	BNC cable BNC-BNC (1 m)	1
BNC cable	366925	BNC cable BNC-BNC (2 m)	1
BNC cable	366926	BNC-alligator cable	1
Adapter	366971	9-pin* to 25-pin** adapter	1
Measurement leads	758917	Red and black, 75 cm; 2 leads in a set	1
Fork terminal adapter set	758921	Converts fork terminal (4 mm) into banana terminal; red and black (one each)	1
Alligator clips adapter (rated voltage: 300 V)	758922	Banana to alligator conversion; 2 in a set	1
Alligator clips adapter (rated voltage: 1000 V)	758929	Banana to alligator conversion; 2 in a set	1
Fuses	A1354EF	250 V, 6.3 Arms, time lag 100 V/200 V	2
External sensor cable	B9284LK	For external input; 50 cm	1
Roll paper for printer	B9316FX	Thermal paper; 10 meters (1 roll)	10

- *: EIA-574 standard
**: EIA-232 standard (RS-232)

NOTICE

- Before operating the product, read the instruction manual thoroughly for proper and safe operation.
- If this product is for use with a system requiring safeguards that directly involve personnel safety, please contact the Yokogawa sales offices.