

All-in-one for GPS interference testing of E911 Services

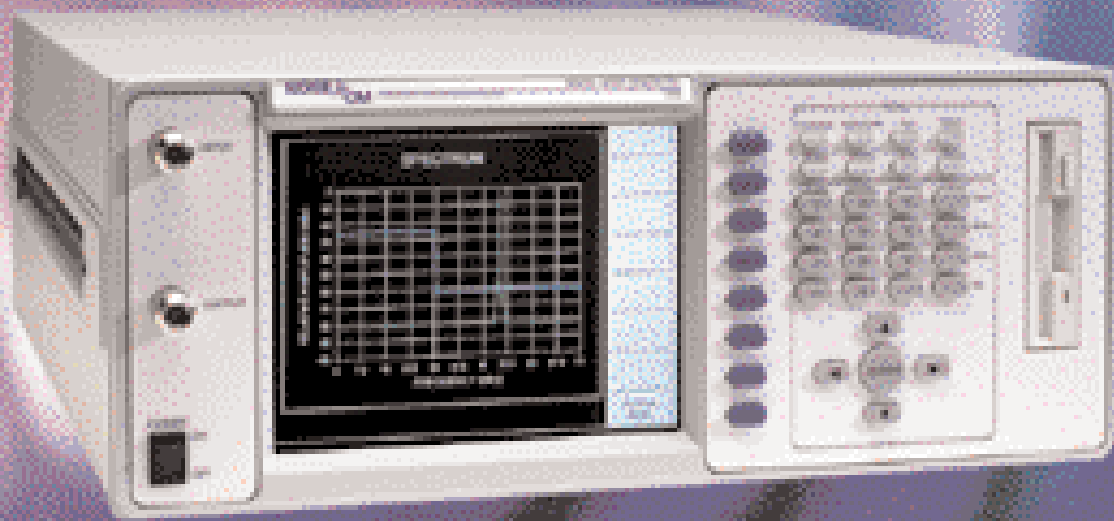

E911 Noise & Interference Generator

NOISE/COM

A WIRELESS TELECOM GROUP COMPANY

E911 Noise & Interference Generator

The Noise Com E911 Noise & Interference Generator is capable of generating up to 40 MHz bandwidth of arbitrary waveforms for the test of susceptibility of GPS receivers to jamming, pulsed, CW, noise and any interference which we could imagine. A modular approach provides for expandability with additional independently programmable generators for L1, L2 or L5 bands. This unique combination allows for a single instrument to support today's as well as possible future GPS standards.

Benefits:

Integrated Approach: Contains one or optionally two independent arbitrary waveform generators. This allows for simultaneous testing of the L1 and L2 or L5 frequencies.

Value: Built-in GPS signal and interference combiner, Gaussian noise source and power meter for automatic high and low power level calibrations.

Protected Investment: As additional independent bands are needed the E911 can be easily upgraded. Arbitrary waveform generator allows creation of any interference or jamming waveform which we could imagine.

Generate Arbitrary Waveform Interference at high power levels anywhere from 800 MHz to the ISM-Band at 2500 MHz. Additionally, connectors are accessible on the rear panel for external customer defined filtering.

True "Standard" for GPS: The GPS7500 was designed to support all of the current GPS tests of susceptibility to noise and interference of E911.

Ease of use: Access table of pre-stored GPS testing parameters made by pressing one button. Cursors automatically lead to GPS standard template, giving the operator a quick view of all necessary test criteria.

Technical Features:

- +21 dBm Output Power
- 800 to 2500 MHz Synthesizer
- 40 MHz Arbitrary Waveform
- 164.5 dB On/Off Ratio
- +/-0.5 ppm over 0 to 50°C

Applications:

GPS Receiver Susceptibility Test and Jamming of:

- Mobile Phone Location and E911 Services
- RTCA DO-229, DO-235 & DO-253
- Galileo
- GLONASS
- Automotive Standards

Noise Com's E911 Noise and Interference Generator was designed to support all the GPS testing requirements in an easy to use platform. Testing receiver susceptibility to interference, intentional or unintentional, has become a requirement and product differentiator in airborne, automotive, defense and mobile phone applications.

While the E911 was originally designed around the airborne GPS Standards, DO-253A, DO-235A and DO-229C with a federal agency as a lead customer, these standards are among the most commanding. Based on Noise Com's digital noise and arbitrary waveform technology, E911 may generate any GPS interference waveform which we could imagine. It is therefore easily applicable to GPS receiver, chip set and system susceptibility testing in airborne, automotive, defense, mobile location and E911 services.

E911 allows for user preset and user defined arbitrary interference and jamming waveforms. Automatic testing parameters for several known GPS requirements have been pre-stored and are available to the operator for ease of use.

The higher bandwidth (>40 MHz) of the E911 allows for interference generation over the entire band. With the two-channel option, measurements can be made simultaneously with independent waveforms at L1 and L2 or L5 over this higher bandwidth.

Built-in calibration and an onboard power meter ensure that measurements will always be accurate. A true Gaussian noise source provides a fixed low level reference to which the output power of the arbitrary waveform can be calibrated. A built-in power meter assists in this calibration as well as in the setting of high output power levels up to +21 dBm.

The E911 has three main modes:

- Continuous Wave (CW) Synthesized.
- Arbitrary Interference including Broadband Gaussian Noise.
- Pulse Mode.

Any arbitrary interference waveform which we could imagine may be generated in the Arbitrary Interference Mode. These waveforms, which may include sine waves, noise, AM etc., can then be pulsed at any duty cycle between 0 and 100% at 6.67 nanoseconds resolution. The pulse on/off ratio of 164.5 dB is obtained in a proprietary switch design also includes circuitry for the reduction of frequency splatter.

The embedded PC allows for user defined waveforms as well as custom programming. The Ethernet port supports connection to a LAN and a TCP/IP command set for remote control.

Modular design allows for a number of options, including dual channels (L1, L2 or L5) and built-in low phase noise synthesizer. An optional GPS signal splitter with dual outputs for both an isolated clean reference output and an interference plus GPS combined output is also available.

E911 Emulates Interference coming from the same frequency bands as:

- GSM
- CDMA
- DCS - 1800
- PCS - 1900
- 3G
- ISM
- WLAN
- BT

Interference Level vs. Frequency

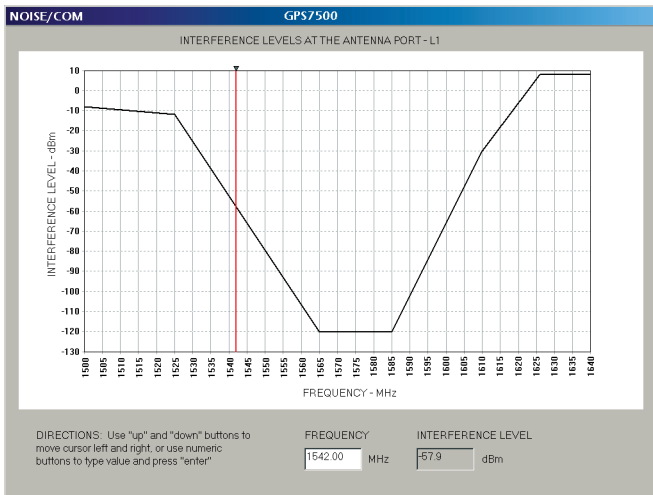

Interference Level vs. Interference Bandwidth

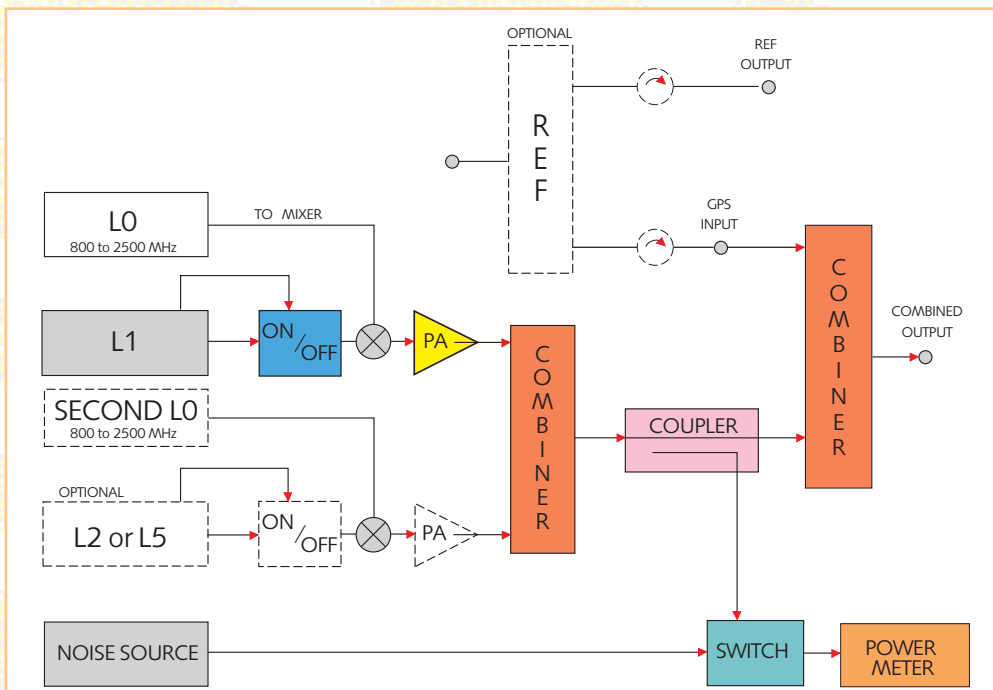
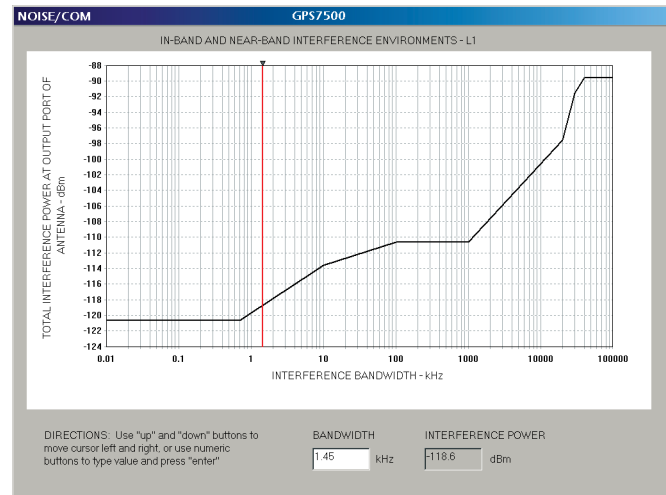

E911 and options

Specifications

Description	Specification	Notes
CW Operating Frequency Range	800 MHz to 2500 MHz	Internal Synthesizer
Noise and Pulse Interference Center Frequencies	1575.42 MHz (L1) and optionally 1227.60 MHz (L2) or 1176.45 MHz (L5) Filtered 800 to 2500 MHz unfiltered (will have image and LO at 110 MHz offset) or by using external bandpass filter on the rear panel	Tunable over +/-20MHz for each Band
Arbitrary Signal (AM, Noise, Pulse) 3dB Bandwidth	0 to 40 MHz	
Frequency Stability	+/- 0.5 ppm	Over 0 to 55 degrees C
Minimum Frequency Resolution	20 kHz	
Phase Noise	-46 dBc/Hz at +/- 20 kHz Offset -122 dBc/Hz at +/- 100 kHz Offset	Maximum All Modes Typical CW Mode
Typical Spurious Output	-52 dBc at <+/- 21.5 MHz Offset -80 dBc at >+/- 21.5 MHz Offset	All Modes CW Mode
Maximum Spurious Output in CW Mode	-122.5 dBc between 1564.42 MHz and 1586.42 MHz	For CW signal at < 1525 MHz or > 1610 MHz
Available Output Power	+10 dBm at 1000 to 2000 MHz +21 dBm at 1555 to 1595 MHz	After internal GPS plus Interference Combiner
Lowest Output Power	-126.5 dBm -170.5 dBm/Hz	All Modes Noise Mode
Output Power Resolution	0.1 dB	
Interference/Signal Ratios	Up to 155 dB	Relative to -134.5 dBm GPS Signal
Minimum Pulse On/Off Ratio	164.5 dB	In Pulse Mode, 1575 to 1595 MHz, > +20 dBm.
Rise & Fall Times	<100 ns	10% to 90%
Pulse Duty Cycle	0 to 100%	
Pulse Width Resolution	6.67 ns	
Pulse Repetition Rates	5 Hz to 75 MHz	
Maximum CW, Noise or Pulse Power at GPS Input	-41.25 dBm/MHz	Isolation to GPS Input

General

Processor	Pentium	
Operating System	XP	
Display	8.4" TFT-LCD Color	
Remote Interface	Ethernet	GPIO Optional
External Reference Input	10 MHz	Internal/External Reference is

Ordering Information

Part Number	Description
E911	Noise & Interference Generator for GPS Testing at L1 Band, 1575.42 MHz +/- 20 MHz.
EoptL2	Additional independently programmable Noise and Interference Generator for L2 band, 1226.20 MHz +/- 20 MHz.
EoptL5	Additional independently programmable Noise and Interference Generator for L5 band, 1176.45 MHz +/- 20 MHz.
EoptREF	GPS Signal Splitter with Isolated GPS Output for Reference Receiver.
Eopt GPIO	Optional. GPIO Remote Control Interface.
Eopt SWEEP	Frequency sweep option. Forward, backwards plus forth-and-back sweep.
Eopt L3	High output option bypassing the internal GPS signal combiners

25 Eastmans Road
 Parsippany, NJ 07054
 Phone: (201) 261-8797
 Fax: (201) 261-8339
 Email: info@noise.com
 Web site: www.noise.com

NOISE/COM
 A WIRELESS TELECOM GROUP COMPANY